



SLOVENSKI STANDARD

SIST EN 455-1:2001

01-november-2001

Nadomešča:

SIST EN 455-1:2000

SIST EN 455-1:2000/A1:2000

Medicinske rokavice za enkratno uporabo - 1. del: Zahteve in preskusi za ugotavljanje odsotnosti lukenj

Medical gloves for single use - Part 1: Requirements and testing for freedom from holes

Medizinische Handschuhe zum einmaligen Gebrauch - Teil 1: Anforderungen und Prüfung auf Dichtheit

Gants médicaux non réutilisables - Partie 1: Détection des trous - Prescriptions et essais

Ta slovenski standard je istoveten z: EN 455-1:2000

ICS:

11.140

Oprema bolnišnic

Hospital equipment

SIST EN 455-1:2001

en

iTeh STANDARD PREVIEW
(standards.iteh.ai)

Full standard:
<https://standards.iteh.ai/catalog/standards/sist/002b2eb5-c03b-4507-a711-5563d7f8d450/sist-en-455-1-2001>

EUROPEAN STANDARD

EN 455-1

NORME EUROPÉENNE

EUROPÄISCHE NORM

October 2000

ICS 13.340

Supersedes EN 455-1:1993

English version

Medical gloves for single use - Part 1: Requirements and testing for freedom from holes

Gants médicaux non réutilisables - Partie 1: Détection des
trous - Prescriptions et essais

Medizinische Handschuhe zum einmaligen Gebrauch - Teil
1: Anforderungen und Prüfung auf Dichtheit

This European Standard was approved by CEN on 16 September 2000.

CEN members are bound to comply with the CEN/CENELEC Internal Regulations which stipulate the conditions for giving this European Standard the status of a national standard without any alteration. Up-to-date lists and bibliographical references concerning such national standards may be obtained on application to the Central Secretariat or to any CEN member.

This European Standard exists in three official versions (English, French, German). A version in any other language made by translation under the responsibility of a CEN member into its own language and notified to the Central Secretariat has the same status as the official versions.

CEN members are the national standards bodies of Austria, Belgium, Czech Republic, Denmark, Finland, France, Germany, Greece, Iceland, Ireland, Italy, Luxembourg, Netherlands, Norway, Portugal, Spain, Sweden, Switzerland and United Kingdom.



EUROPEAN COMMITTEE FOR STANDARDIZATION
COMITÉ EUROPÉEN DE NORMALISATION
EUROPÄISCHES KOMITEE FÜR NORMUNG

Central Secretariat: rue de Stassart, 36 B-1050 Brussels

Page 2
EN 455-1:2000

Foreword

This European Standard has been prepared by Technical Committee CEN/TC 205 "Non-active medical devices", the secretariat of which is held by BSI.

This European Standard supersedes EN 455-1:1993

This European Standard shall be given the status of a national standard, either by publication of an identical text or by endorsement, at the latest by April 2001, and conflicting national standards shall be withdrawn at the latest by April 2001.

This European Standard has been prepared under a mandate given to CEN by the European Commission and the European Free Trade Association, and supports essential requirements of EU Directive(s).

For relationship with EU Directive(s), see informative Annex ZA, which is an integral part of this standard.

This European Standard applies to medical gloves for single use and has been prepared in three parts. This part addresses freedom from holes; Part 2 addresses physical properties and Part 3 addresses requirements and testing for biological evaluation.

According to the CEN/CENELEC Internal Regulations, the national standards organizations of the following countries are bound to implement this European Standard: Austria, Belgium, Czech Republic, Denmark, Finland, France, Germany, Greece, Iceland, Ireland, Italy, Luxembourg, Netherlands, Norway, Portugal, Spain, Sweden, Switzerland and the United Kingdom.

1 Scope

This part of this Standard specifies requirements and gives the test method for medical gloves for single use in order to determine freedom from holes.

NOTE Attention is drawn to EN 374-1 "Protective gloves against chemicals and micro-organisms – Part 1: Terminology and performance requirements".

2 Normative Reference

This European Standard incorporates by dated or undated reference, provisions from other publications. These normative references are cited at the appropriate places in the text and the publications are listed hereafter. For dated references, subsequent amendments to or revisions of any of these publications apply to this European Standard only when incorporated in it by amendment or revision. For undated references the latest edition of the publication referred to applies (including amendments).

ISO 2859-1

Sampling procedures for inspection by attributes – Part 1: Sampling plans indexed by acceptable quality level (AQL) for lot-by-lot inspection.

3 Term and definition

For the purposes of this standard the following term and definition apply:

3.1

medical gloves for single use

gloves intended for use in the medical field to protect patient and user from cross-contamination.

4 Requirement

Medical gloves for single use shall not leak when tested in accordance with clause 5.

5 Watertightness test for detection of holes

5.1 Referee testing

Vertically position a filling tube of dimensions shown in figure 1 or of dimensions to fit the glove and such that the tube is capable of holding any of the 1000 ml of water that may exceed the natural fill volume of the glove.

Attach the glove to the filling tube, overlapping the cuff by a maximum of 40 mm over the end of the tube and secure it by suitable means to obtain a watertight seal without damaging the glove (see figure 1).

Add 1000 ml \pm 50 ml of water at a temperature of (15 to 35) °C into the open end of the filling tube, allowing the water to pass freely into the glove.

NOTE Some of the water may remain in the filling tube depending on the glove being tested.

Immediately inspect the glove visually for water leakage. Allow the glove to hang and visually inspect the glove for water leakage again after a period of 2 min to 3 min.

If, because of distension of the glove, the water does not rise to within 40 mm of the cuff end, raise the glove after the second inspection by a suitable means until the water level reaches 40 mm from the cuff end. Inspect visually the previously untested portion of the glove after a further period of 2 min to 3 min.

Disregard leakages within 40 mm of the cuff.

5.2 Routine testing

Routine testing shall be either by the watertightness test given in 5.1 or by another test which is validated against this test.

6 Sampling, inspection level and AQL

Each lot shall be sampled in accordance with ISO 2859-1 general inspection level 1, but utilising a minimum sample size and corresponding acceptance/rejection numbers equivalent to sample size code letter L. When tested by the method described in 5.1 for referee purpose, the compliance level for freedom from holes shall be an AQL of 1,5.

NOTE This inspection level meets the requirements of Annex IV point 6.3 of the Medical Devices Directive, 93/42/EEC, and does not entail excessive sample sizes which would impact on manufacturing and testing costs. A minimum sample size equivalent to sample size code letter L is necessary to ensure that an adequate assessment of the quality of the lot is obtained when the lot size is small or unknown.

7 Test report

Any test report shall include at least the following information:

- a reference to this part of EN 455;
- the type of gloves and manufacturing batch code;
- the name and address of the manufacturer or distributor and test laboratory, if different;

Page 4
EN 455-1:2000

- the date of the test performed;
- the test results (batch size, sample size, number of non-conforming gloves).

iTeh STANDARD PREVIEW
(standards.iteh.ai)

Full standard:
<https://standards.iteh.ai/catalog/standards/sist/002b2eb5-c03b-4507-a711-5563d7f8d450/sist-en-455-1-2001>

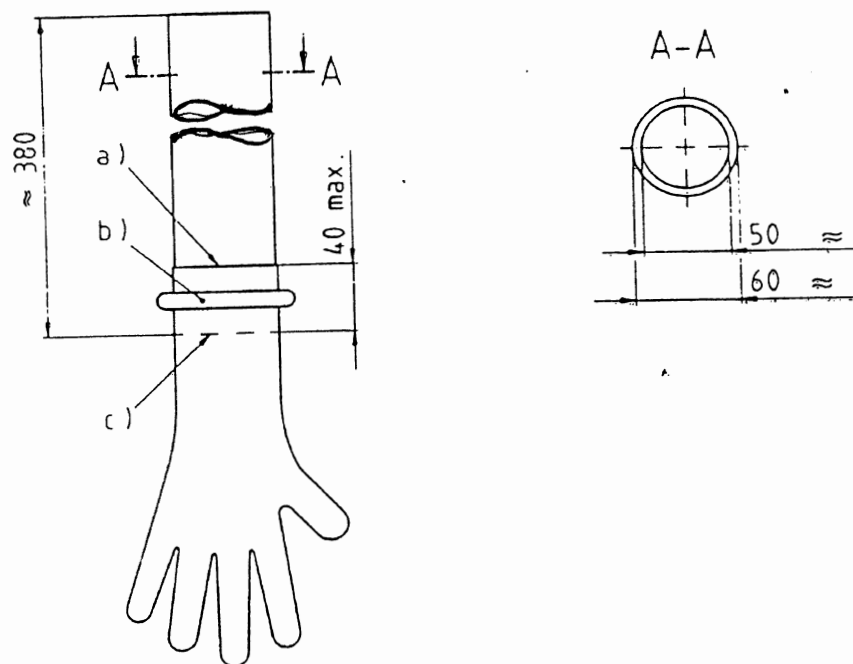

Key

- a) Cuff end of glove
- b) Locking device
- c) Fill tube overlapping

Figure 1 - Watertightness test - Filling tube

iTeh STANDARD PREVIEW
(standards.iteh.ai)
Full standard:
<https://standards.iteh.ai/catalog/standards/sist/002b2eb5-c03b-4507-a15563d7f8d450/sist-en-455-1-2001>

Page 6
EN 455-1:2000

Annex ZA (informative)

Clauses of this European Standard addressing essential requirements or other provisions of EU Directives

This European standard has been prepared under a mandate given to CEN/CENELEC by the European commission and the European Free Trade Association and supports essential requirements of EU Directive 93/42/EEC.

WARNING Other requirements and other EU Directives may be applicable to the product(s) falling within the scope of this standard.

The following clauses of this standard, as detailed in table ZA.1, are likely to support requirements of Directive 93/42/EEC.

Compliance with the clauses of this standard provides one means of conforming with the specific essential requirements of the Directive concerned and associated EFTA regulations.

Table ZA.1 - Correspondence between this European Standard and EU Directives

Clause/sub-clause of this European Standard	Corresponding essential requirement of Directive 93/42/EEC	Comments
4	1, 2, 3, 7.2, 8.1	
5	1, 2, 3, 7.2	
5.2	8.1	
6	1, 2, 7.2, 8.1	
7	1, 2, 8.1	

iTeh STANDARD PREVIEW
(standards.iteh.ai)
Full standard:
<https://standards.iteh.ai/catalog/standards/sist/002b2eb5-c03b-4507-a711-5563d78d450/sist-en-455-1-2001>