



Designation: C204 – 07

American Association State
Highway and Transportation Officials Standard
AASHTO No.: T 153

Standard Test Methods for Fineness of Hydraulic Cement by Air-Permeability Apparatus¹

This standard is issued under the fixed designation C204; the number immediately following the designation indicates the year of original adoption or, in the case of revision, the year of last revision. A number in parentheses indicates the year of last reapproval. A superscript epsilon (ϵ) indicates an editorial change since the last revision or reapproval.

1. Scope*

1.1 This test method covers determination of the fineness of hydraulic cement, using the Blaine air-permeability apparatus, in terms of the specific surface expressed as total surface area in square centimetres per gram, or square metres per kilogram, of cement. Two test methods are given: Test Method A is the Reference Test Method using the manually operated standard Blaine apparatus, while Test Method B permits the use of automated apparatus that has in accordance with the qualification requirements of this test method demonstrated acceptable performance. Although the test method may be, and has been, used for the determination of the measures of fineness of various other materials, it should be understood that, in general, relative rather than absolute fineness values are obtained.

1.1.1 This test method is known to work well for portland cements. However, the user should exercise judgement in determining its suitability with regard to fineness measurements of cements with densities, or porosities that differ from those assigned to Standard Reference Material No. 114.

1.2 The values stated in SI units are to be regarded as the standard.

1.3 *This standard does not purport to address all of the safety concerns, if any, associated with its use. It is the responsibility of the user of this standard to establish appropriate safety and health practices and determine the applicability of regulatory limitations prior to use.*

2. Referenced Documents

2.1 ASTM Standards:²

[A582/A582M Specification for Free-Machining Stainless Steel Bars](#)

[C670 Practice for Preparing Precision and Bias Statements for Test Methods for Construction Materials](#)

¹ This test method is under the jurisdiction of ASTM Committee C01 on Cement and is the direct responsibility of Subcommittee C01.25 on Fineness.

Current edition approved Aug. 1, 2007. Published September 2007. Originally approved in 1946. Last previous edition approved in 2005 as C204 – 05. DOI: 10.1520/C0204-07.

² For referenced ASTM standards, visit the ASTM website, www.astm.org, or contact ASTM Customer Service at service@astm.org. For *Annual Book of ASTM Standards* volume information, refer to the standard's Document Summary page on the ASTM website.

[E832 Specification for Laboratory Filter Papers](#)

2.2 Other Document:

[No. 114 National Institute of Standards and Technology Standard Reference Material³](#)

[BS 4359: 1971 British Standard Method for the Determination of Specific Surface of Powders: Part 2: Air Permeability Methods⁴](#)

TEST METHOD A: REFERENCE METHOD

3. Apparatus

3.1 *Nature of Apparatus*—The Blaine air-permeability apparatus consists essentially of a means of drawing a definite quantity of air through a prepared bed of cement of definite porosity. The number and size of the pores in a prepared bed of definite porosity is a function of the size of the particles and determines the rate of airflow through the bed. The apparatus, illustrated in Fig. 1, shall consist specifically of the parts described in 3.2-3.8.

3.2 *Permeability Cell*—The permeability cell shall consist of a rigid cylinder 12.70 ± 0.10 mm in inside diameter, constructed of austenitic stainless steel. The interior of the cell shall have a finish of $0.81 \mu\text{m}$ ($32 \mu\text{in.}$). The top of the cell shall be at right angles to the principal axis of the cell. The lower portion of the cell must be able to form an airtight fit with the upper end of the manometer, so that there is no air leakage between the contacting surfaces. A ledge $\frac{1}{2}$ to 1 mm in width shall be an integral part of the cell or be firmly fixed in the cell 55 ± 10 mm from the top of the cell for support of the perforated metal disk. The top of the permeability cell shall be fitted with a protruding collar to facilitate the removal of the cell from the manometer.

NOTE 1—Specification [A582/A582M](#) Type 303 stainless steel (UNS designation S30300) has been found to be suitable for the construction of the permeability cell and the plunger.

3.3 *Disk*—The disk shall be constructed of noncorroding metal and shall be 0.9 ± 0.1 mm in thickness, perforated with 30 to 40 holes 1 mm in diameter equally distributed over its

³ Available from National Institute of Standards and Technology (NIST), 100 Bureau Dr., Stop 1070, Gaithersburg, MD 20899-1070, <http://www.nist.gov>.

⁴ Available from British Standards Institute (BSI), 389 Chiswick High Rd., London W4 4AL, U.K., <http://www.bsi-global.com>.

*A Summary of Changes section appears at the end of this standard.

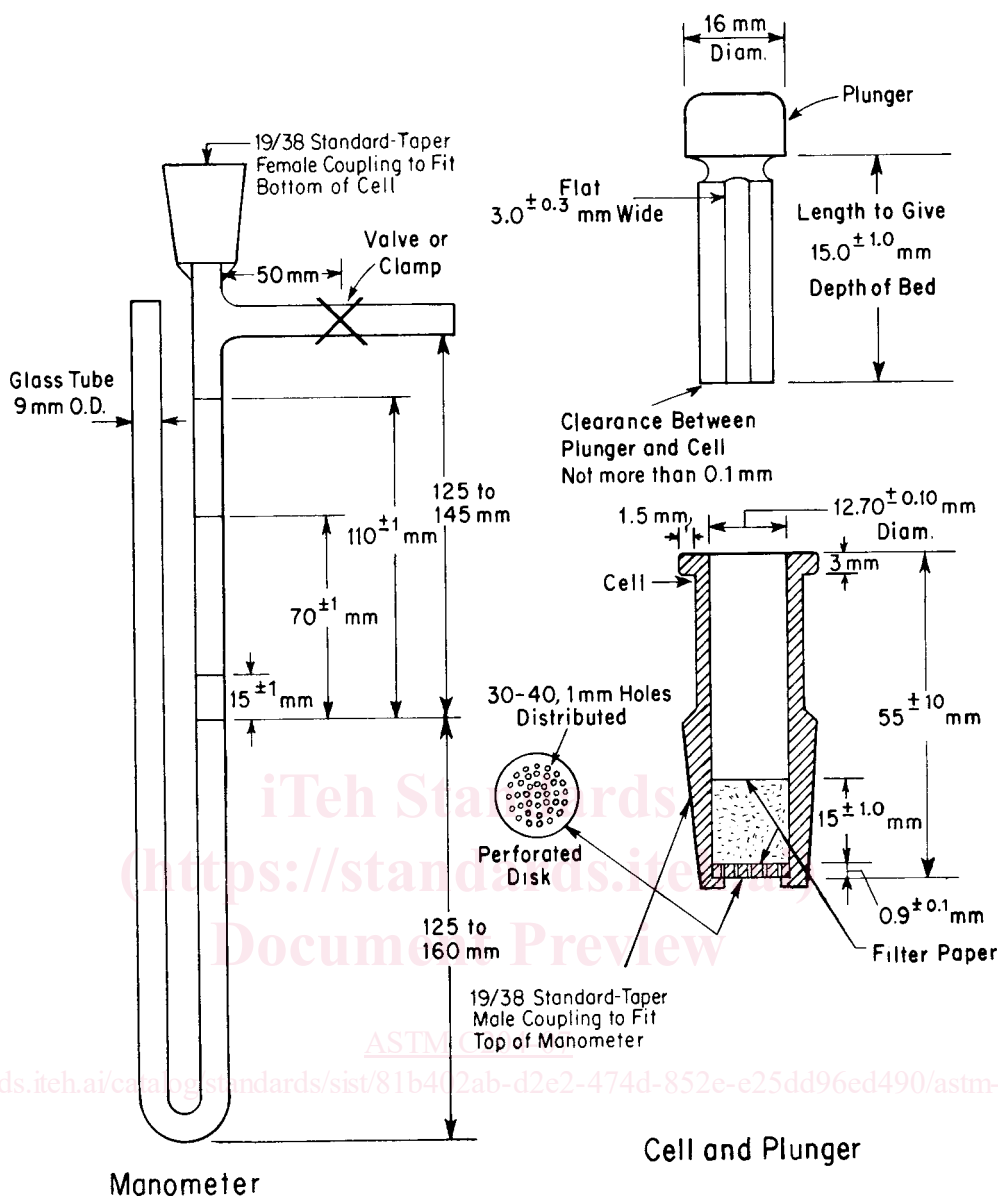

FIG. 1 Blaine Air-Permeability Apparatus

area. The disk shall fit the inside of the cell snugly. The center portion of one side of the disk shall be marked or inscribed in a legible manner so as to permit the operator always to place that side downwards when inserting it into the cell. The marking or inscription shall not extend into any of the holes, nor touch their peripheries, nor extend into that area of the disk that rests on the cell ledge.

3.4 *Plunger*—The plunger shall be constructed of austenitic stainless steel and shall fit into the cell with a clearance of not more than 0.1 mm. The bottom of the plunger shall sharply meet the lateral surfaces and shall be at right angles to the principal axis. An air vent shall be provided by means of a flat 3.0 ± 0.3 mm wide on one side of the plunger. The top of the plunger shall be provided with a collar such that when the plunger is placed in the cell and the collar brought in contact with the top of the cell, the distance between the bottom of the plunger and the top of the perforated disk shall be 15 ± 1 mm.

3.5 *Filter Paper*—The filter paper shall be medium retentive, corresponding to Type 1, Grade B, in accordance with Specification E832. The filter paper disks shall be circular, with smooth edges, and shall have the same diameter (Note 2) as the inside of the cell.

NOTE 2—Filter paper disks that are too small may leave part of the sample adhering to the inner wall of the cell above the top disk. When too large in diameter, the disks have a tendency to buckle and cause erratic results.

3.6 *Manometer*—The U-tube manometer shall be constructed according to the design indicated in Fig. 1, using nominal 9-mm outside diameter, standard-wall, glass tubing. The top of one arm of the manometer shall form an airtight connection with the permeability cell. The manometer arm connected to the permeability cell shall have a midpoint line etched around the tube at 125 to 145 mm below the top side

outlet and also others at distances of 15 ± 1 mm, 70 ± 1 mm, and 110 ± 1 mm above that line. A side outlet shall be provided at 250 to 305 mm above the bottom of the manometer for use in the evacuation of the manometer arm connected to the permeability cell. A positive airtight valve or clamp shall be provided on the side outlet not more than 50 mm from the manometer arm. The manometer shall be mounted firmly and in such a manner that the arms are vertical.

3.7 Manometer Liquid—The manometer shall be filled to the midpoint line with a nonvolatile, nonhygroscopic liquid of low viscosity and density, such as dibutyl phthalate (dibutyl 1,2-benzene-dicarboxylate) or a light grade of mineral oil. The fluid shall be free of debris.

3.8 Timer—The timer shall have a positive starting and stopping mechanism and shall be capable of being read to the nearest 0.5 s or less. The timer shall be accurate to 0.5 s or less for time intervals up to 60 s, and to 1 % or less for time intervals of 60 to 300 s.

4. Calibration of Apparatus

4.1 Sample—The calibration of the air permeability apparatus shall be made using the current lot of NIST Standard Reference Material **No. 114**. The sample shall be at room temperature when tested.

4.2 Bulk Volume of Compacted Bed of Powder—Determine the bulk volume of the compacted bed of powder by the mercury displacement method as follows:

4.2.1 Place two filter paper disks in the permeability cell, pressing down the edges, using a rod having a diameter slightly smaller than that of the cell, until the filter disks are flat on the perforated metal disk; then fill the cell with mercury, ACS reagent grade or better, removing any air bubbles adhering to the wall of the cell. Use tongs when handling the cell. If the cell is made of material that will amalgamate with mercury, the interior of the cell shall be protected by a very thin film of oil just prior to adding the mercury. Level the mercury with the top of the cell by lightly pressing a small glass plate against the mercury surface until the glass is flush to the surface of the mercury and rim of the cell, being sure that no bubble or void exists between the mercury surface and the glass plate. Remove the mercury from the cell and measure and record the mass of the mercury. Remove one of the filter disks from the cell. Using a trial quantity of 2.80 g of cement (**Note 3**) compress the cement (**Note 4**) in accordance with **4.5** with one filter disk above and one below the sample. Into the unfilled space at the top of the cell, add mercury, remove entrapped air, and level off the top as before. Remove the mercury from the cell and measure and record the mass of the mercury.

4.2.2 Calculate the bulk volume occupied by the cement to the nearest 0.005 cm^3 as follows:

$$V = (W_A - W_B)/D \quad (1)$$

where:

- V = bulk volume of cement, cm^3 ,
- W_A = grams of mercury required to fill the cell, no cement being in the cell,

W_B = grams of mercury required to fill the portion of the cell not occupied by the prepared bed of cement in the cell, and

D = density of mercury at the temperature of test, Mg/m^3 (see **Table 1**).

4.2.3 Make at least two determinations of bulk volume of cement, using separate compactions for each determination. The bulk volume value used for subsequent calculations shall be the average of two values agreeing within $\pm 0.005 \text{ cm}^3$. Note the temperature in the vicinity of the cell and record at the beginning and end of the determination.

NOTE 3—It is not necessary to use the standard sample for the bulk volume determination.

NOTE 4—The prepared bed of cement shall be firm. If too loose or if the cement cannot be compressed to the desired volume, adjust the trial quantity of cement used.

4.3 Preparation of Sample—Enclose the contents of a vial of the standard cement sample in a jar, approximately 120 cm^3 (4 oz), and shake vigorously for 2 min to fluff the cement and break up lumps or agglomerates. Allow the jar to stand unopened for a further 2 min, then remove the lid and stir gently to distribute throughout the sample the fine fraction that has settled on the surface after fluffing.

4.4 Mass of Sample—The mass of the standard sample used for the calibration test shall be that required to produce a bed of cement having a porosity of 0.500 ± 0.005 , and shall be calculated as follows:

$$W = \rho V(1 - \varepsilon) \quad (2)$$

where:

- W = grams of sample required,
- ρ = density of test sample (for portland cement a value of 3.15 Mg/m^3 or 3.15 g/cm^3 shall be used),
- V = bulk volume of bed of cement, cm^3 , as determined in accordance with **4.2**, and
- ε = desired porosity of bed of cement (0.500 ± 0.005) (**Note 5**).

NOTE 5—The porosity is the ratio of volume of voids in a bed of cement to the total or bulk volume of the bed, V .

4.5 Preparation of Bed of Cement—Seat the perforated disk on the ledge in the permeability cell, inscribed or marked face down. Place a filter paper disk on the metal disk and press the edges down with a rod having a diameter slightly smaller than that of the cell. Measure the mass to the nearest 0.001 g the

TABLE 1 Density of Mercury, Viscosity of Air (η), and $\sqrt{\eta}$ at Given Temperatures

Room Temperature, °C	Density of Mercury, Mg/m^3	Viscosity of Air, η , $\mu\text{Pa}\cdot\text{s}$	$\sqrt{\eta}$
18	13.55	17.98	4.24
20	13.55	18.08	4.25
22	13.54	18.18	4.26
24	13.54	18.28	4.28
26	13.53	18.37	4.29
28	13.53	18.47	4.30
30	13.52	18.57	4.31
32	13.52	18.67	4.32
34	13.51	18.76	4.33

quantity of cement determined in accordance with 4.4 and place in the cell. Tap the side of the cell lightly in order to level the bed of cement. Place a filter paper disk on top of the cement and compress the cement with the plunger until the plunger collar is in contact with the top of the cell. Slowly withdraw the plunger a short distance, rotate about 90°, repress, and then slowly withdraw. Use of fresh paper filter disks is required for each determination.

4.6 Permeability Test:

4.6.1 Attach the permeability cell to the manometer tube, making certain that an airtight connection is obtained (Note 6) and taking care not to jar or disturb the prepared bed of cement.

4.6.2 Slowly evacuate the air in the one arm of the manometer U-tube until the liquid reaches the top mark, and then close the valve tightly. Start the timer when the bottom of the meniscus of the manometer liquid reaches the second (next to the top) mark and stop when the bottom of the meniscus of liquid reaches the third (next to the bottom) mark. Note the time interval measured and record in seconds. Note the temperature of test and record in degrees Celsius.

4.6.3 In the calibration of the instrument, make at least three determinations of the time of flow on each of three separately prepared beds of the standard sample (Note 7). The calibration shall be made by the same operator who makes the fineness determination.

NOTE 6—A little stopcock grease should be applied to the standard taper connection. The efficiency of the connection can be determined by attaching the cell to the manometer, stoppering it, partially evacuating the one arm of the manometer, then closing the valve. Any continuous drop in pressure indicates a leak in the system.

NOTE 7—The sample may be refluffed and reused for preparation of the test bed, provided that it is kept dry and all tests are made within 4 h of the opening of the sample.

4.7 Recalibration—The apparatus shall be recalibrated (Note 8):

4.7.1 At periodic intervals, the duration of which shall not exceed 2½ years, to correct for possible wear on the plunger or permeability cell, or upon receipt of evidence that the test is not providing data in accordance with the precision and bias statement in Section 8.

4.7.2 If any loss in the manometer fluid occurs, recalibrate starting with 4.5, or

4.7.3 If a change is made in the type or quality of the filter paper used for the tests.

NOTE 8—It is suggested that a secondary sample be prepared and used as a fineness standard for the check determinations of the instrument between regular calibrations with the standard cement sample.

5. Procedure

5.1 *Temperature of Cement*—The cement sample shall be at room temperature when tested.

5.2 *Size of Test Sample*—The weight of sample used for the test shall be the same as that used in the calibration test on the standard sample, with these exceptions: When determining the fineness of Type III or other types of fine-ground portland cement whose bulk for this mass is so great that ordinary thumb pressure will not cause the plunger collar to contact the top of the cell, the weight of the sample shall be that required to produce a test bed having a porosity of 0.530 ± 0.005 . When

determining the fineness of materials other than portland cement, or if for a portland cement sample one of the required porosities cannot be attained, the mass of the sample shall be adjusted so that a firm, hard bed is produced by the compacting process. In no case, however, shall more than thumb pressure be used to secure the proper bed, nor shall such thumb pressure be used that the plunger “rebounds” from the cell top when pressure is removed.

5.3 *Preparation of Bed of Cement*—Prepare the test bed of cement in accordance with the method described in 4.5.

5.4 *Permeability Tests*—Make the permeability tests in accordance with the method described in 4.6, except that only one time-of-flow determination need be made on each bed.

6. Calculation

6.1 Calculate the specific surface values in accordance with the following equations:

$$S = \frac{S_s \sqrt{T}}{\sqrt{T_s}} \quad (3)$$

$$S = \frac{S_s \sqrt{\eta_s} \sqrt{T}}{\sqrt{T_s} \sqrt{\eta}} \quad (4)$$

$$S = \frac{S_s (b - \varepsilon_s) \sqrt{\varepsilon_s^3} \sqrt{T}}{\sqrt{\varepsilon_s^3} \sqrt{T_s} (b - \varepsilon)} \quad (5)$$

$$S = \frac{S_s (b - \varepsilon_s) \sqrt{\varepsilon_s^3} \sqrt{\eta} \sqrt{T}}{\sqrt{\varepsilon_s^3} \sqrt{T_s} \sqrt{\eta} (b - \varepsilon)} \quad (6)$$

$$S = \frac{S_s \rho_s (b_s - \varepsilon_s) \sqrt{\varepsilon_s^3} \sqrt{T}}{\rho (b - \varepsilon) \sqrt{\varepsilon_s^3} \sqrt{T_s}} \quad (7)$$

$$S = \frac{S_s \rho_s (b_s - \varepsilon_s) \sqrt{\eta_s} \sqrt{\varepsilon_s^3} \sqrt{T}}{\rho (b - \varepsilon) \sqrt{\varepsilon_s^3} \sqrt{T_s} \sqrt{\eta}} \quad (8)$$

where:

- S = specific surface of the test sample, m^2/kg ,
- S_s = specific surface of the standard sample used in calibration of the apparatus, m^2/kg (Note 9),
- T = measured time interval, s, of manometer drop for test sample (Note 10),
- T_s = measured time interval, s, of manometer drop for standard sample used in calibration of the apparatus (Note 10),
- η = viscosity of air, micro pascal seconds ($\mu Pa \cdot s$), at the temperature of test of the test sample (Note 10),
- η_s = viscosity of air, micro pascal seconds ($\mu Pa \cdot s$), at the temperature of test of the standard sample used in calibration of the apparatus (Note 10),
- ε = porosity of prepared bed of test sample (Note 10),
- $\varepsilon \varepsilon_s$ = porosity of prepared bed of standard sample used in calibration of apparatus (Note 10),
- ρ = density of test sample (for portland cement a value of 3.15 Mg/m^3 or 3.15 g/cm^3 shall be used),
- ρ_s = density of standard sample used in calibration of apparatus (assumed to be 3.15 Mg/m^3 or 3.15 g/cm^3),
- b = a constant specifically appropriate for the test sample (for hydraulic cement a value of 0.9 shall be used), and