



SLOVENSKI STANDARD

SIST ISO 5291:2013

01-december-2013

Nadomešča:
SIST ISO 5291:1997

Jermenski pogoni - Profil žleba jermenice za običajne klinaste jermene - Sekcije žlebov vrste AJ, BJ, CJ in DJ

Belt drives - Grooved pulleys for joined classical V-belts - Groove sections AJ, BJ, CJ and DJ (effective system)

iTeh STANDARD PREVIEW
(standards.iteh.ai)

Transmissions par courroies - Poulies à gorges pour courroies trapézoïdales jumelées classiques - Sections de gorge AJ, BJ, CJ et DJ (système effectif)

<https://standards.iteh.ai/catalog/standards/sist/f02c1e3d-eddb-4feF-af10-18b885e298e6/sist-iso-5291-2013>

Ta slovenski standard je istoveten z: ISO 5291:2011

ICS:

21.220.10	Jermenski pogoni in njihovi deli	Belt drives and their components
-----------	----------------------------------	----------------------------------

SIST ISO 5291:2013

en

iTeh STANDARD PREVIEW
(standards.iteh.ai)

[SIST ISO 5291:2013](#)

<https://standards.iteh.ai/catalog/standards/sist/f02c1e3d-eddb-4fef-af10-18b885e298e6/sist-iso-5291-2013>

INTERNATIONAL STANDARD

ISO 5291

Third edition
2011-12-15

Belt drives — Grooved pulleys for joined classical V-belts — Groove sections AJ, BJ, CJ and DJ (effective system)

*Transmissions par courroies — Poulies à gorges pour courroies
trapézoïdales jumelées classiques — Sections de gorge AJ, BJ, CJ et
DJ (système effectif)*

iTeh STANDARD PREVIEW
(standards.iteh.ai)

[SIST ISO 5291:2013](https://standards.iteh.ai/catalog/standards/sist/f02c1e3d-eddb-4fef-af10-18b885e298e6/sist-iso-5291-2013)

<https://standards.iteh.ai/catalog/standards/sist/f02c1e3d-eddb-4fef-af10-18b885e298e6/sist-iso-5291-2013>



Reference number
ISO 5291:2011(E)

© ISO 2011

iTeh STANDARD PREVIEW (standards.iteh.ai)

SIST ISO 5291:2013

<https://standards.iteh.ai/catalog/standards/sist/f02c1e3d-eddb-4fef-af10-18b885e298e6/sist-iso-5291-2013>



COPYRIGHT PROTECTED DOCUMENT

© ISO 2011

All rights reserved. Unless otherwise specified, no part of this publication may be reproduced or utilized in any form or by any means, electronic or mechanical, including photocopying and microfilm, without permission in writing from either ISO at the address below or ISO's member body in the country of the requester.

ISO copyright office
Case postale 56 • CH-1211 Geneva 20
Tel. + 41 22 749 01 11
Fax + 41 22 749 09 47
E-mail copyright@iso.org
Web www.iso.org

Published in Switzerland

Foreword

ISO (the International Organization for Standardization) is a worldwide federation of national standards bodies (ISO member bodies). The work of preparing International Standards is normally carried out through ISO technical committees. Each member body interested in a subject for which a technical committee has been established has the right to be represented on that committee. International organizations, governmental and non-governmental, in liaison with ISO, also take part in the work. ISO collaborates closely with the International Electrotechnical Commission (IEC) on all matters of electrotechnical standardization.

International Standards are drafted in accordance with the rules given in the ISO/IEC Directives, Part 2.

The main task of technical committees is to prepare International Standards. Draft International Standards adopted by the technical committees are circulated to the member bodies for voting. Publication as an International Standard requires approval by at least 75 % of the member bodies casting a vote.

Attention is drawn to the possibility that some of the elements of this document may be the subject of patent rights. ISO shall not be held responsible for identifying any or all such patent rights.

ISO 5291 was prepared by Technical Committee ISO/TC 41, *Pulleys and belts (including veebelts)*, Subcommittee SC 1, *Friction*.

This third edition cancels and replaces the second edition (ISO 5291:1993), of which it constitutes a minor revision.

iTeh STANDARD PREVIEW
(standards.iteh.ai)

SIST ISO 5291:2013
<https://standards.iteh.ai/catalog/standards/sist/f02c1e3d-eddb-4fef-af10-18b885e298e6/sist-iso-5291-2013>

iTeh STANDARD PREVIEW
(standards.iteh.ai)

SIST ISO 5291:2013

<https://standards.iteh.ai/catalog/standards/sist/f02c1e3d-eddb-4fef-af10-18b885e298e6/sist-iso-5291-2013>

Belt drives — Grooved pulleys for joined classical V-belts — Groove sections AJ, BJ, CJ and DJ (effective system)

1 Scope

This International Standard specifies the principal characteristics of grooved pulleys (for groove sections AJ, BJ, CJ and DJ), intended to take joined classical V-belts for industrial power transmission drives.

NOTE 1 The effective width of a groove is regarded as the basic dimension of standardization for grooves and for the corresponding joined V-belts considered as a whole.

NOTE 2 The pitch line position can only be given approximately. The approximate pitch diameter of a pulley can be calculated by the following formula:

$$d_p = d_e - 2b_e$$

2 Normative references

The following referenced documents are indispensable for the application of this document. For dated references, only the edition cited applies. For undated references, the latest edition of the referenced document (including any amendments) applies.

ISO 254, *Belt drives — Pulleys — Quality, finish and balance*

ISO 1081, *Belt drives — V-belts and V-ribbed belts, and corresponding grooved pulleys — Vocabulary*

ISO 9980:1990, *Belt drives — Grooved pulleys for V-belts (system based on effective width) — Geometrical inspection of grooves*

3 Terms and definitions

For the purposes of this document, the terms and definitions given in ISO 1081 (drives using V-belts, i.e. belts and grooved pulleys) apply.

4 Specifications

4.1 Groove profiles

4.1.1 Groove angle, α

The groove angle (see Figure 1) shall have one of the following values:

- $\alpha = 34^\circ$ (for groove sections AJ, BJ and CJ only);
- $\alpha = 36^\circ$ (for groove section DJ only);
- $\alpha = 38^\circ$.

ISO 5291:2011(E)

The relationship between the groove angle and the range of effective diameters which should be used is given in Table 2.

4.1.2 Profile dimensions

The dimensions shown in Figures 1 and 2 shall have the values specified in Table 1.

The actual diameter should not be greater than $d_e + 2\delta h_1$. The straight sides of the groove should be at least as high as $d_e - 2\delta h_2$.

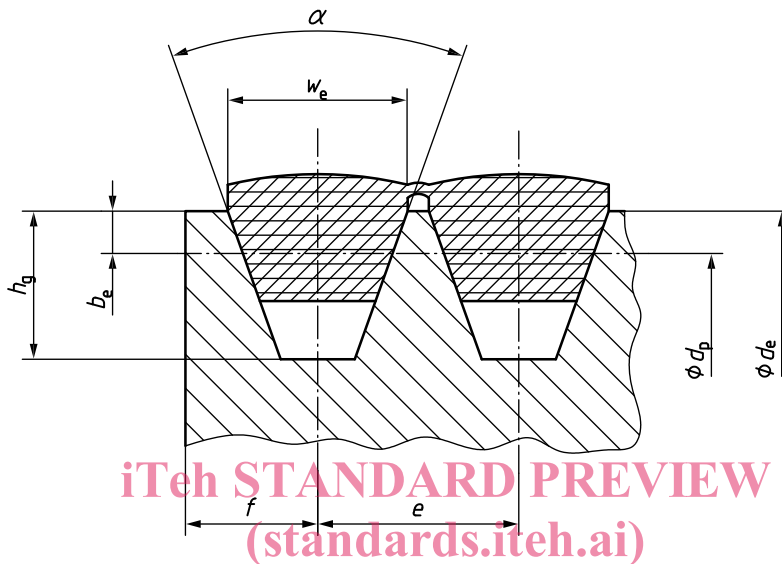

Figure 1 ISO 5291:2013

<https://standards.iteh.ai/catalog/standards/sist/f02c1e3d-eddb-4fef-af10-18b885e298e6/sist-iso-5291-2013>

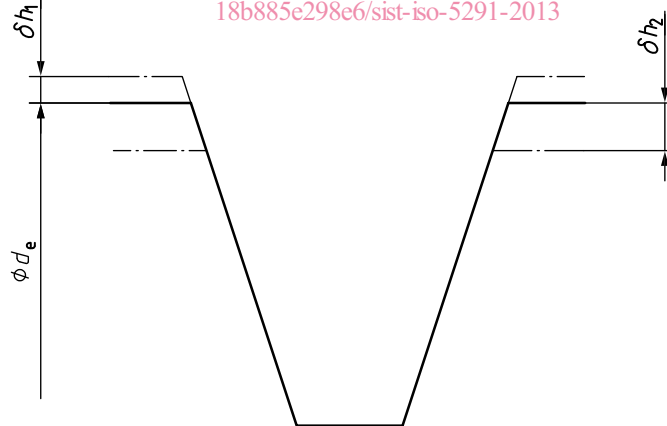

Figure 2

Table 1 — Profile dimensions

Groove section	w_e	δh_1	δh_2	b_e	h_g	e	Tolerance on e^a	Sum of deviation of e^b	f^c min.
AJ	13	0,2	0,35	1,5	12	15,88	$\pm 0,3$	$\pm 0,6$	9
BJ	16,5	0,25	0,4	2	14	19,05	$\pm 0,4$	$\pm 0,8$	11,5
CJ	22,4	0,3	0,45	3	19	25,4	$\pm 0,5$	± 1	16
DJ	32,8	0,3	0,55	4,5	26	36,53	$\pm 0,6$	$\pm 1,2$	23

^a This tolerance applies to the distance between the axes of two consecutive groove profiles.

^b The sum of all deviation from the nominal value e for all grooves in any one pulley shall not exceed the value stated in this table.

^c Variations of f shall be taken into consideration in the alignment of the pulleys.

4.2 Effective diameter, d_e

4.2.1 Series of effective diameters — Groove angles in relation to given effective diameters

See Table 2.

Table 2 — Groove angles
iTech STANDARD PREVIEW
(standards.itech.ai)

Dimensions in millimetres

Groove section	Groove angles, α		
	34°	36°	38°
	Effective diameters, d_e		
AJ	$d_e \leq 125$		$d_e > 125$
BJ	$d_e \leq 195$		$d_e > 195$
CJ	$d_e \leq 325$		$d_e > 325$
DJ		$d_e \leq 490$	$d_e > 490$

4.2.2 Smallest effective diameters in relation to given groove sections

See Table 3.

Table 3 — Smallest effective diameters

Groove section	Smallest effective diameter
	mm
AJ	80
BJ	130
CJ	210
DJ	370