**Road vehicles — Ergonomic
requirements for the driver's
workplace in line-service buses —**

**Part 1:
General description, basic requirements**

iTeh STANDARD PREVIEW
*Véhicules routiers — Exigences ergonomiques du poste de conduite
dans les bus de ville —
(standards.iteh.ai)
Partie 1: Description générale, exigences de base*

ISO 16121-1:2012

<https://standards.iteh.ai/catalog/standards/sist/65a3b17c-c41f-4014-bd3c-31fb4774cdd6/iso-16121-1-2012>



iTeh STANDARD PREVIEW
(standards.iteh.ai)

ISO 16121-1:2012

<https://standards.iteh.ai/catalog/standards/sist/65a3b17c-c41f-4014-bd3c-31fb4774cdd6/iso-16121-1-2012>



COPYRIGHT PROTECTED DOCUMENT

© ISO 2012

All rights reserved. Unless otherwise specified, no part of this publication may be reproduced or utilized in any form or by any means, electronic or mechanical, including photocopying and microfilm, without permission in writing from either ISO at the address below or ISO's member body in the country of the requester.

ISO copyright office
Case postale 56 • CH-1211 Geneva 20
Tel. + 41 22 749 01 11
Fax + 41 22 749 09 47
E-mail copyright@iso.org
Web www.iso.org

Published in Switzerland

Contents

	Page
Foreword	iv
Introduction	v
1 Scope	1
2 Normative references	1
3 Terms and definitions	1
4 Basic requirements	2
4.1 Dimensions.....	2
4.2 Driver's workplace in general.....	5
4.3 Driver's seat.....	6
4.4 Pedals.....	9
4.5 Steering wheel.....	12
Bibliography	14

iTeh STANDARD PREVIEW (standards.iteh.ai)

[ISO 16121-1:2012](https://standards.iteh.ai/catalog/standards/sist/65a3b17c-c41f-4014-bd3c-31fb4774cdd6/iso-16121-1-2012)

<https://standards.iteh.ai/catalog/standards/sist/65a3b17c-c41f-4014-bd3c-31fb4774cdd6/iso-16121-1-2012>

Foreword

ISO (the International Organization for Standardization) is a worldwide federation of national standards bodies (ISO member bodies). The work of preparing International Standards is normally carried out through ISO technical committees. Each member body interested in a subject for which a technical committee has been established has the right to be represented on that committee. International organizations, governmental and non-governmental, in liaison with ISO, also take part in the work. ISO collaborates closely with the International Electrotechnical Commission (IEC) on all matters of electrotechnical standardization.

International Standards are drafted in accordance with the rules given in the ISO/IEC Directives, Part 2.

The main task of technical committees is to prepare International Standards. Draft International Standards adopted by the technical committees are circulated to the member bodies for voting. Publication as an International Standard requires approval by at least 75 % of the member bodies casting a vote.

Attention is drawn to the possibility that some of the elements of this document may be the subject of patent rights. ISO shall not be held responsible for identifying any or all such patent rights.

ISO 16121-1 was prepared by Technical Committee ISO/TC 22, *Road vehicles*, Subcommittee SC 13, *Ergonomics applicable to road vehicles*.

This second edition cancels and replaces the first edition (ISO 16121-1:2005), which has been technically revised.

ISO 16121 consists of the following parts under the general title *Road vehicles — Ergonomic requirements for the driver's workplace in line-service buses*:

- Part 1: *General description, basic requirements* [ISO 16121-1:2012](https://standards.iteh.ai/catalog/standards/sist/65a3b17c-c41f-4014-bd3c-31fb4774cdd6/iso-16121-1-2012)
- Part 2: *Visibility* <https://standards.iteh.ai/catalog/standards/sist/65a3b17c-c41f-4014-bd3c-31fb4774cdd6/iso-16121-1-2012>
- Part 3: *Information devices and controls*
- Part 4: *Cabin environment*

Introduction

Poor ergonomics in the driver's workplace in buses designed to provide scheduled urban and interurban services increase the already high physical and mental strains on the drivers.

It is the aim of this part of ISO 16121 to supply the designer of line-service buses with information about how to develop an overall ergonomic concept for the driver's workplace. The recommended requirements on the driver's workplace for line-service buses made in this part of ISO 16121 are based on the scientific conclusions of the research project "Driver's workplace in the line-service bus". This was conducted in Germany and summarized in the VDV 234 [3] recommendation. Further comprehensive ergonomic studies related to the design of an enhanced driver workplace conducted in the United States, Canada, the Netherlands, Sweden and the United Kingdom [4, 5, 6, 7, 8] have been considered and found to provide recommendations covering similar areas.

This part of ISO 16121 sets out to consider the practical implications for all ranges of drivers, but particularly those with statures from 1,55 m (small female) to 2,0 m (large male). These statures include shoes (~30 mm).

It is also essential that the designer refers to the specifications and requirements of all parts of ISO 16121 (Parts 1 to 4) before completing the design of a driver's workplace.

It should be noted that where there is also national legislation covering any of the subjects contained herein, then both should be complied with. However, if a contradiction between the two should arise in any specific area, then the legislation should prevail for that specific point only. Other technical solutions, at least equal with regard to ergonomics, should not be excluded.

ITEH STANDARD PREVIEW

(standards.iteh.ai)

[ISO 16121-1:2012](https://standards.iteh.ai/catalog/standards/sist/65a3b17c-c41f-4014-bd3c-31fb4774cdd6/iso-16121-1-2012)

<https://standards.iteh.ai/catalog/standards/sist/65a3b17c-c41f-4014-bd3c-31fb4774cdd6/iso-16121-1-2012>

iTeh STANDARD PREVIEW
(standards.iteh.ai)

ISO 16121-1:2012

<https://standards.iteh.ai/catalog/standards/sist/65a3b17c-c41f-4014-bd3c-31fb4774cdd6/iso-16121-1-2012>

Road vehicles — Ergonomic requirements for the driver's workplace in line-service buses —

Part 1: General description, basic requirements

1 Scope

This part of ISO 16121 applies to the driver's workplace in low-floor line-service buses designed for the carriage of passengers, comprising more than eight seats in addition to the driver's seat, and having a maximum weight exceeding five metric tonnes and an overall width exceeding 2,30 m.

This part of ISO 16121 contains basic requirements for an ergonomic and comfortable seating position, which is essential to keep drivers in a good state of health. The dimensions and mounting positions of a driver's seat, pedals and steering should be carefully chosen to enable drivers to sit in an ergonomic seating position, i.e. sitting at angles which comply with the given ranges of comfort and to allow some variation when seated.

2 Normative references

The following referenced documents are indispensable for the application of this document. For dated references, only the edition cited applies. For undated references, the latest edition of the referenced document (including any amendments) applies.

ISO 2575, Road vehicles — *Symbols for controls, indicators and tell-tales*

ISO 6549, Road vehicles — *Procedure for H- and R-point determination*¹⁾

ISO 10326-1, Mechanical vibration — *Laboratory method for evaluating vehicle seat vibration — Part 1: Basic requirements*

ISO 16121-3, Road vehicles — *Ergonomic requirements for the driver's workplace in line-service buses — Part 3: Information devices and controls*

3 Terms and definitions

For the purposes of this document, the following terms and definitions apply.

3.1

low-floor

vehicle in which at least 35 % of the area available for standing passengers (or of its forward section in the case of an articulated vehicle) forms a single area without steps, reached through at least one service door by a single step from the ground

3.2

required values

values representing present state of the art that, when applied, achieve an acceptable level of ergonomic design

1) International Standard withdrawn.

3.3

recommended values

values representing the preferred ergonomic conditions that are desirable for the future development of the driver's workplace

3.4

zero-X-plane

vertical transverse plane through the Accelerator Heel Point (AHP), vertical to the longitudinal median plane of the bus

3.5

zero-Y-plane

median plane of driver (in driving posture) parallel to the longitudinal median plane of the bus

3.6

zero-Z-plane

horizontal plane through the Accelerator Heel Point (AHP)

3.7

Accelerator Heel Point

AHP

intersection of the driver's right heel, when the foot is positioned against the accelerator pedal in its idle position, and the surface of the depressed floor covering or other heel support

3.8

heel point line

AHP line

intersection line of the zero-X-plane with the zero-Z-plane

iTeh STANDARD PREVIEW
(standards.iteh.ai)

4 Basic requirements

ISO 16121-1:2012
<https://standards.iteh.ai/catalog/standards/sist/65a3b17c-c41f-4014-bd3c-31fb4774cdd6/iso-16121-1-2012>

4.1 Dimensions

4.1.1 Reference system

All dimensions in the driver's workplace refer to a driver-based system of coordinates (see Figure 1).

The reference system is formed by the zero-X-plane, zero-Y-plane and zero-Z-plane, which are perpendicular to each other.

The intersection point (coordinate origin) of all three planes corresponds to the AHP projected onto the zero-Y-plane. The intersection line of the zero-X-plane with the zero-Z-plane is referred to as the AHP Line.

The X, Y and Z axes are oriented so that the negative coordinate range lies in front of the zero-X-plane, on the left of the zero-Y-plane and below the zero-Z-plane, when one is looking in the direction of driving forward.

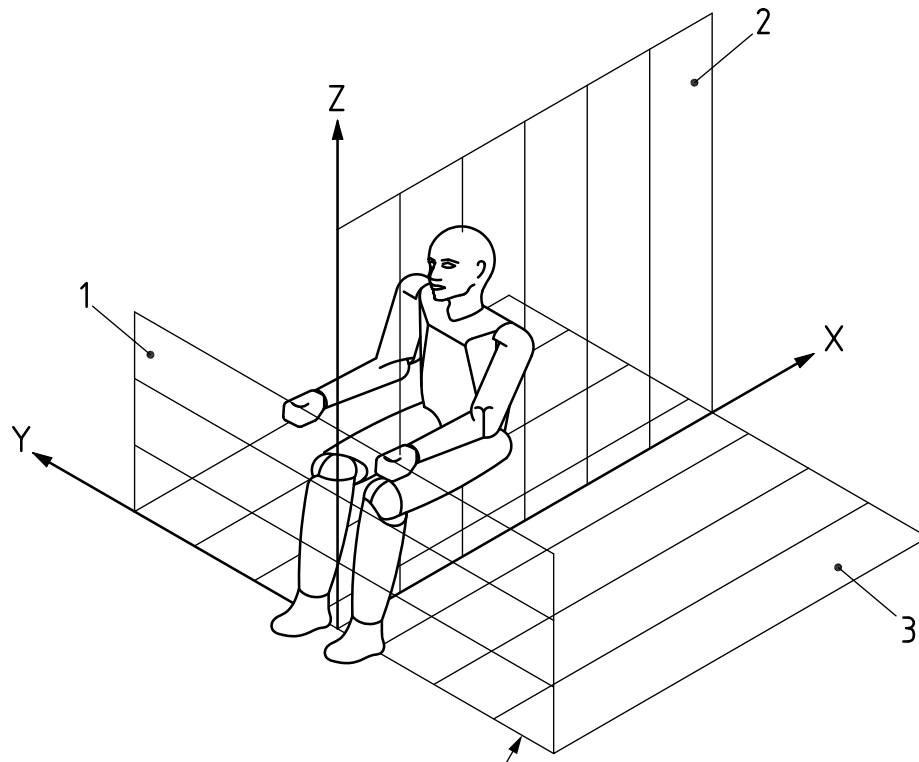

iTeh STANDARD PREVIEW
(standards.iteh.ai)

Key

- 1 zero-X-plane
- 2 zero-Y-plane
- 3 zero-Z-plane
- 4 AHP line

ISO 16121-1:2012
<https://standards.iteh.ai/catalog/standards/sist/65a3b17c-c41f-4014-bd3c-31fb4774cdd6/iso-16121-1-2012>

Figure 1 — Driver-based system of coordinates

4.1.2 Tolerances

For linear measures a tolerance of ± 10 mm shall be valid, unless otherwise specified. This tolerance, however, is not applicable when dimensions are specified as a range of values (e.g. $x = 10$ mm to 30 mm).

4.1.3 AHP

The AHP is defined for three basic types of throttle pedal design as follows:

- For treadle (organ) type pedals (see Figure 2a), the AHP is the intersection of the depressed floor or other heel support with a line projected from the upper surface of the throttle pedal.
- For hanging (pendulum) type pedals (see Figure 2b), the AHP is the point which intersects with the depressed floor or other heel support when an arc 200 mm in length is taken from the centre of the pedal surface.
- For treadle (organ) type pedals with a fixed heel stop (see Figure 2c), the AHP shall be taken as the intersection between the heel stop and the pedal surface.

In all cases, the AHP shall lie on the vertical centreline of the pedal.

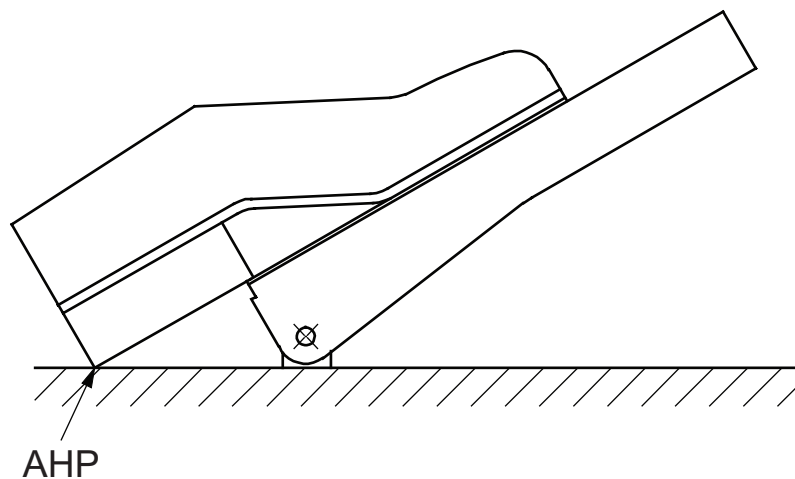

a) Treadle type pedal with no heel stop

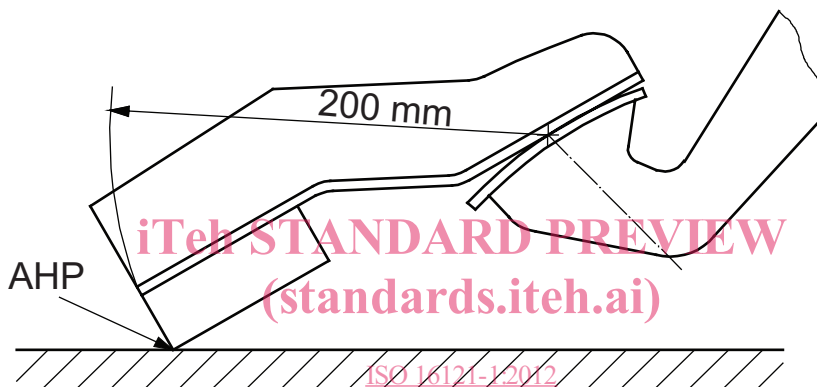

ISO 16121-1:2012
<https://standards.iteh.ai/catalog/standards/sist/65a3b17c-c41f-4014-bd3c-474111111111/iso-16121-1-2012>

b) Pendulum type pedal

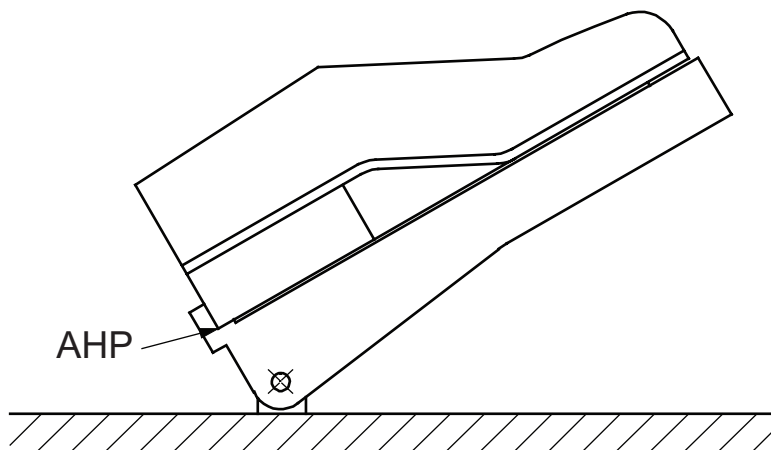

c) Treadle type pedal with heel stop

Figure 2 — Determination of Accelerator Heel Point, AHP

4.2 Driver's workplace in general

4.2.1 Size of driver's workplace

4.2.1.1 Driver's workplace length

The length of the driver's workplace (inside dimension) shall be such that the driver can attain the full range of adjustment (see Table 1), including swivel (where such a mechanism is fitted) without restriction. The depth of the footwell shall be at least 350 mm (see Figure 3) forward of AHP.

4.2.1.2 Driver's workplace width

The width of the driver's workplace shall be chosen in such a way that sufficient distance to all interior surfaces to either side of the driver (laterally from head to foot) and sufficient leg freedom are available, including space for seat swivel. For the protection of the fingers a clearance distance of 25 mm from the outer extremities of the seat shall be kept.

The minimum lateral elbow room (y_{\min}) in the shoulder range shall be 800 mm for all seat positions during driving.

4.2.2 Access to the driver's workplace

In low-floor buses, the driver's workplace should be arranged on a platform. It is recommended that this platform be at a height of 300 ± 50 mm above the floor and be reached by a single step. If the platform height is greater than 350 mm, steps with equal height shall be provided with a maximum height of 250 mm and a minimum height of 125 mm.

Clear and unrestricted access to the driver's workplace shall be ensured, with a passage width of at least 500 mm.

These requirements are for normal entrance to the driver's workplace and do not necessarily apply to additional emergency exit doors.

4.2.3 Stowage space

In the driver's workplace, a space for the driver's bag should be provided, e.g. in the cabin door. The stowage dimensions (length \times height \times width) for the driver's bag should be at least 480 mm \times 330 mm \times 170 mm (240 mm preferred, where possible).

It should be possible to open the bag for the withdrawal of objects in the compartment. For personal objects needed during the drive (e.g. sunglasses) additional, easy-to-reach, non-slip stowage space should be available.

A coat hook should be provided inside the driver's cabin. A coat hung on the coat hook shall not interfere with the operation of controls nor obstruct the driver's view. Optionally, a hanger may be provided.

A lockable compartment for valuables shall be available.

4.2.4 Wall

A wall should be provided behind the driver.