



Designation: G105 – 02(Reapproved 2007)

Standard Test Method for Conducting Wet Sand/Rubber Wheel Abrasion Tests¹

This standard is issued under the fixed designation G105; the number immediately following the designation indicates the year of original adoption or, in the case of revision, the year of last revision. A number in parentheses indicates the year of last reapproval. A superscript epsilon (ϵ) indicates an editorial change since the last revision or reapproval.

1. Scope

1.1 This test method covers laboratory procedures for determining the resistance of metallic materials to scratching abrasion by means of the wet sand/rubber wheel test. It is the intent of this procedure to provide data that will reproducibly rank materials in their resistance to scratching abrasion under a specified set of conditions.

1.2 Abrasion test results are reported as volume loss in cubic millimeters. Materials of higher abrasion resistance will have a lower volume loss.

1.3 The values stated in SI units are to be regarded as standard. The values given in parentheses are for information only.

1.4 *This standard does not purport to address all of the safety concerns, if any, associated with its use. It is the responsibility of the user of this standard to establish appropriate safety and health practices and determine the applicability of regulatory limitations prior to use.*

2. Referenced Documents

2.1 ASTM Standards:²

D2000 Classification System for Rubber Products in Automotive Applications

D2240 Test Method for Rubber Property—Durometer Hardness

E11 Specification for Woven Wire Test Sieve Cloth and Test Sieves

E122 Practice for Calculating Sample Size to Estimate, With Specified Precision, the Average for a Characteristic of a Lot or Process

E177 Practice for Use of the Terms Precision and Bias in ASTM Test Methods

G40 Terminology Relating to Wear and Erosion

¹ This test method is under the jurisdiction of ASTM Committee G02 on Wear and Erosion and is the direct responsibility of Subcommittee G02.30 on Abrasive Wear.

Current edition approved July 1, 2007. Published September 2007. Originally approved in 1989. Last previous edition approved in 2002 as G105-02. DOI: 10.1520/G0105-02R07.

² For referenced ASTM standards, visit the ASTM website, www.astm.org, or contact ASTM Customer Service at service@astm.org. For *Annual Book of ASTM Standards* volume information, refer to the standard's Document Summary page on the ASTM website.

2.2 SAE Standard:³

SAE J200 Classification System for Rubber Materials

3. Terminology

3.1 Definitions:

3.1.1 *abrasive wear*—wear due to hard particles or hard protuberances forced against and moving along a solid surface.

3.1.1.1 *Discussion*—This definition covers several different wear modes or mechanisms that fall under the abrasive wear category. These modes may degrade a surface by scratching, cutting, deformation, or gouging (**1 and 2**).⁴ **G40**

4. Summary of Test Method

4.1 The wet sand/rubber wheel abrasion test (**Fig. 1**) involves the abrading of a standard test specimen with a slurry containing grit of controlled size and composition. The abrasive is introduced between the test specimen and a rotating wheel with a neoprene rubber tire or rim of a specified hardness. The test specimen is pressed against the rotating wheel at a specified force by means of a lever arm while the grit abrades the test surface. The rotation of the wheel is such that stirring paddles on both sides agitate the abrasive slurry through which it passes to provide grit particles to be carried across the contact face in the direction of wheel rotation.

4.2 Three wheels are required with nominal Shore A Durometer hardnesses of 50, 60, and 70, with a hardness tolerance of ± 2.0 . A run-in is conducted with the 50 Durometer wheel, followed by the test with 50, 60, and 70 Durometer wheels in order of increasing hardness. Specimens are weighed before and after each run and the loss in mass recorded. The logarithms of mass loss are plotted as a function of measured rubber wheel hardness and a test value is determined from a least square line as the mass loss at 60.0 Durometer. It is necessary to convert the mass loss to volume loss, due to wide differences in density of materials, in order to obtain a ranking of materials. Abrasion is then reported as volume loss in cubic millimetres.

³ Available from Society of Automotive Engineers (SAE), 400 Commonwealth Dr., Warrendale, PA 15096-0001.

⁴ The boldface numbers in parentheses refer to the list of references at the end of this standard.

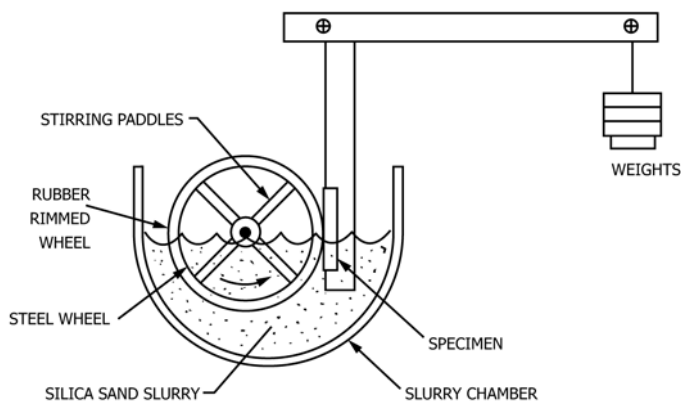

FIG. 1 Schematic Diagram of the Wear Test Apparatus

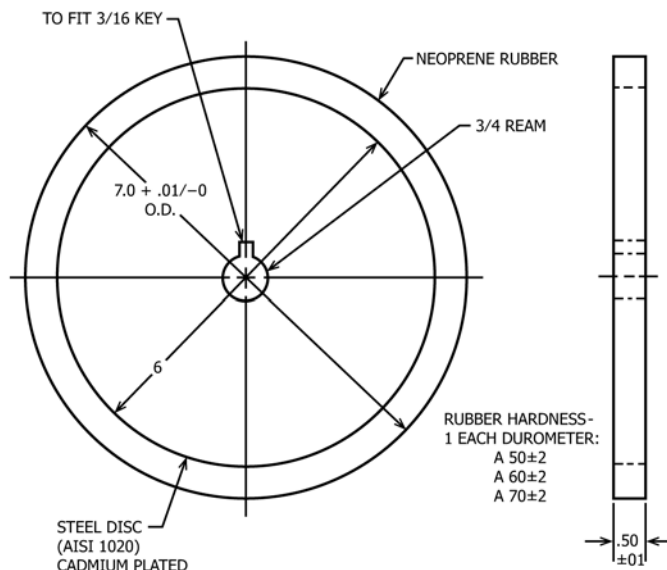

FIG. 2 Rubber Wheel

5. Significance and Use (1-7)

5.1 The severity of abrasive wear in any system will depend upon the abrasive particle size, shape and hardness, the magnitude of the stress imposed by the particle, and the frequency of contact of the abrasive particle. In this test method these conditions are standardized to develop a uniform condition of wear which has been referred to as scratching abrasion (1 and 2). Since the test method does not attempt to duplicate all of the process conditions (abrasive size, shape, pressure, impact or corrosive elements), it should not be used to predict the exact resistance of a given material in a specific environment. The value of the test method lies in predicting the ranking of materials in a similar relative order of merit as would occur in an abrasive environment. Volume loss data obtained from test materials whose lives are unknown in a specific abrasive environment may, however, be compared with test data obtained from a material whose life is known in the same environment. The comparison will provide a general indication of the worth of the unknown materials if abrasion is the predominant factor causing deterioration of the materials.

6. Apparatus⁵

6.1 Fig. 2 shows a typical design and Figs. 3 and 4 are photographs of a test apparatus. (See Ref (4).) Several elements are of critical importance to ensure uniformity in test results among laboratories. These are the type of rubber used on the wheel, the type of abrasive and its shape, uniformity of the test apparatus, a suitable lever arm system to apply the required force (see Note 1) and test material uniformity.

NOTE 1—An apparatus design that is commercially available is depicted both schematically and in photographs in Figs. 1-4. Although it has been used by several laboratories (including those running interlaboratory tests) to obtain wear data, it incorporates what may be considered a design flaw. The location of the pivot point between the lever arm and the specimen holder is not directly in line with the test specimen surface. Unless the tangent to the wheel at the center point of the area or line of contact between the wheel and specimen also passes through the pivot axis of the loading arm, a variable, undefined, and uncompensated torque about the pivot will be caused by the frictional drag of the wheel against the

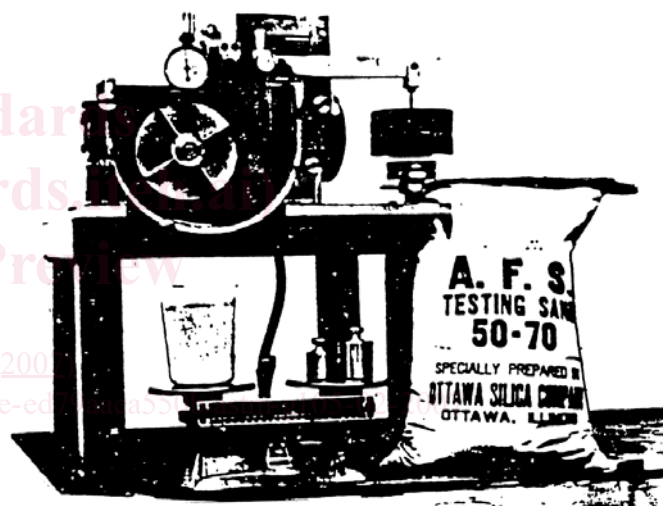

FIG. 3 Test Apparatus with Slurry Chamber Cover Removed

specimen. Therefore, the true loading of specimen against the wheel cannot be known.

6.1.1 Discussion—The location of the pivot point between the lever arm and the specimen holder must be directly in line with the test specimen surface. Unless the tangent to the wheel at the center point of the area or line of contact between the wheel and specimen also passes through the pivot axis of the loading arm, a variable, undefined, and uncompensated torque about the pivot will be caused by the frictional drag of the wheel against the specimen. Therefore, the true loading of specimen against the wheel cannot be known.

6.2 Rubber Wheel—Each wheel shall consist of a steel disk with an outer layer of neoprene rubber molded to its periphery. The rubber is bonded to the rim and cured in a suitable steel mold. Wheels are nominally 178 mm (7 in.) diameter by 13 mm (1/2 in.) wide (see Fig. 2). The rubber will conform to Classification D2000 (SAE J200).

⁵ Present users of this test method may have constructed their own equipment. Rubber wheel abrasion testing equipment is commercially available. Rubber wheels or remolded rims on wheel hubs can be obtained through the manufacturer(s).