



Designation: D 4476 – 97

Standard Test Method for Flexural Properties of Fiber Reinforced Pultruded Plastic Rods¹

This standard is issued under the fixed designation D 4476; the number immediately following the designation indicates the year of original adoption or, in the case of revision, the year of last revision. A number in parentheses indicates the year of last reappraisal. A superscript epsilon (ϵ) indicates an editorial change since the last revision or reappraisal.

1. Scope *

1.1 This test method covers the determination of the flexural properties of fiber-reinforced pultruded plastic rods. The specimen is a rod with a semicircular cross section, molded or cut from lengths of pultruded rods (see Fig. 1). This test method is designed for rods with a diameter of $\frac{1}{2}$ in. or greater.

NOTE 1—There is no ISO equivalent for this standard.

1.2 The values stated in SI units are to be regarded as the standard.

1.3 This standard does not purport to address all of the safety concerns, if any, associated with its use. It is the responsibility of the user of this standard to establish appropriate safety and health practices and determine the applicability of regulatory limitations prior to use.

2. Referenced Documents

2.1 ASTM Standards:

D 618 Practice for Conditioning Plastics and Electrical Insulating Materials for Testing²

D 883 Terminology Relating to Plastics²

D 3918 Definitions of Terms Relating to Reinforced Plastic Pultruded Parts³

E 4 Practices for Load Verification of Testing Machines⁴

E 691 Practice for Conducting an Interlaboratory Study to Determine the Precision of a Test Method⁵

3. Terminology

3.1 For definitions of terms used in this test method, see Terminology D 883 or Definitions D 3918.

4. Summary of Test Method

4.1 A rod of semicircular construction is tested in flexure as a simple beam. The specimen rests on two supports and is

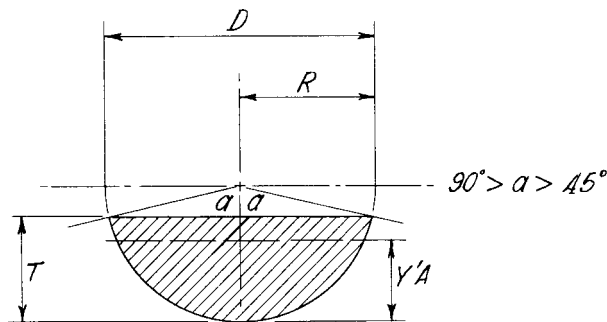

FIG. 1 Cross Section of Test Specimen

loaded by means of a loading nose midway between the supports (see Fig. 3).

4.2 The specimen is deflected until rupture occurs in the outer fibers, or until the maximum fiber strain of 5 % is reached, whichever occurs first.

5. Significance and Use

5.1 Flexural properties determined by this test method are

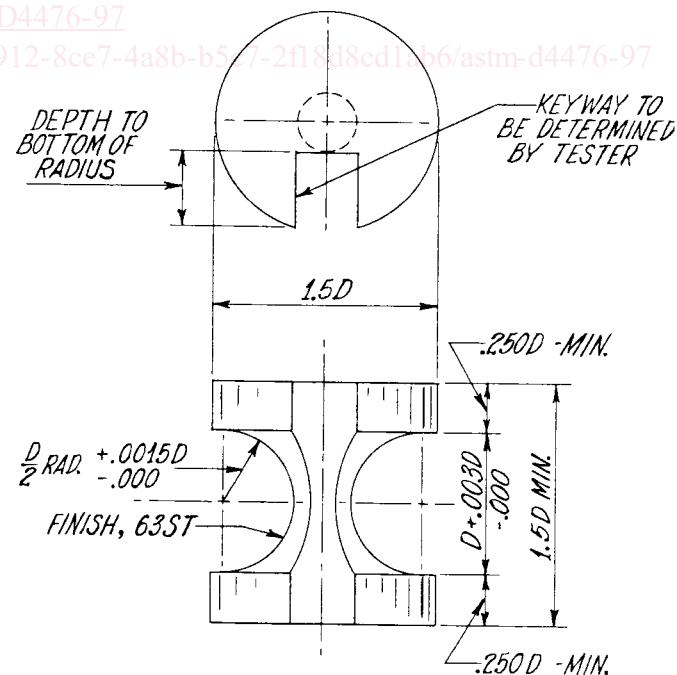

FIG. 2 Arbor Dimensions

¹ This test method is under the jurisdiction of ASTM Committee D-20 on Plastics and is the direct responsibility of Subcommittee D20.18 on Reinforced Thermosetting Plastics.

Current edition approved Nov. 10, 1997. Published April 1998. Originally published as D 4476 – 85. Last previous edition D 4476 – 85 (1990).

² Annual Book of ASTM Standards, Vol 08.01.

³ Annual Book of ASTM Standards, Vol 08.02.

⁴ Annual Book of ASTM Standards, Vol 03.01.

⁵ Annual Book of ASTM Standards, Vol 14.02.

*A Summary of Changes section appears at the end of this standard.

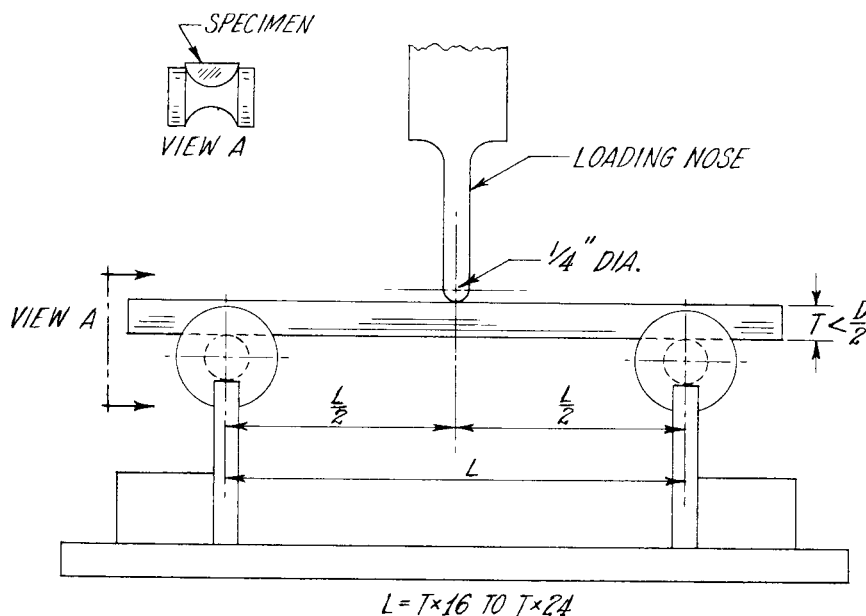

FIG. 3 Schematic of Flexural Test

especially useful for quality control and specification purposes.

5.2 The maximum axial fiber stresses occur on a line under the loading nose. The use of the semicircular cross section eliminates premature compression shear that has been noted in three-point flexure tests on full-round rods.

5.3 Flexural properties may vary with specimen depth, temperature, atmospheric conditions, and differences in rate of straining.

5.4 Before proceeding with this test method, reference should be made to the specification of the material being tested. Any test specimen preparation, conditioning, dimensions, or testing parameters, or combination thereof, covered in the materials specification shall take precedence over those mentioned in this test method. If there are no material specifications, then the default conditions apply.

6. Apparatus

6.1 *Testing Machine*—A properly calibrated testing machine that can be operated at constant rates of crosshead motion over the range indicated, and in which the error in the load-measuring system shall not exceed $\pm 1\%$ of the maximum load expected to be measured. It shall be equipped with a deflection-measuring device. The stiffness of the testing machine shall be such that the total elastic deformation of the system does not exceed 1% of the total deflection of the test specimen during test, or appropriate corrections shall be made. The load-indicating mechanism shall be essentially free of inertial lag at the crosshead rate used. The accuracy of the testing machine shall be verified in accordance with Practices E 4.

6.2 *Loading Nose and Supports*—The loading nose shall have cylindrical surfaces. In order to avoid excessive indentation or failure due to stress concentration directly under the loading nose, the radius of the nose shall be at least 6.4 mm ($\frac{1}{4}$ in.) for all specimens. Larger-radius noses are recommended if significant indentation or compressive failure occurs. The curvature of the loading nose in contact with the specimen shall

be sufficiently large to prevent contact of the specimen with the sides of the nose. The supports shall consist of anvils to support the round section of the segment (see Fig. 2).

6.3 *Micrometers*—Suitable micrometers for measuring the diameter of the test specimen to an incremental discrimination of at least 0.025 mm (0.001 in.) shall be used.

7. Test Specimen

7.1 The test specimen shall consist of a pultruded rod cut into two parts so that the cross section of each part is smaller than a half-round section (see Fig. 1).

7.2 The specimen length shall be 16 to 24 times its thickness or depth, plus at least 20% of the support span to allow a minimum of 10% overhang at the supports (see Fig. 3).

NOTE 2—As a general rule, support span-to-depth ratios of 16 to 1 are satisfactory when the ratio of the tensile strength to shear strength is less than 20 to 1, but the support span-to-depth ratio should be increased for composite laminates having relatively low shear strength in the plane of the laminate and relatively high tensile strength parallel to the support span.

7.3 *Number of Specimens*—The number of test specimens is optional. However, a minimum of five specimens is required to obtain a satisfactory average and standard deviation.

8. Conditioning

8.1 *Conditioning*—Condition the test specimen at $23 \pm 2^\circ\text{C}$ ($73.4 \pm 3.6^\circ\text{F}$) and $50 \pm 5\%$ relative humidity for not less than 40 h prior to test in accordance with Procedure A of Practice D 618, for those tests where conditioning is required. In cases of disagreement, the tolerances shall be $\pm 1^\circ\text{C}$ ($\pm 1.8^\circ\text{F}$) and $\pm 2\%$ relative humidity. These conditions are recommended for research and development trials, but not necessarily for quality control. However, temperature control to $22.2 \pm 5.6^\circ\text{C}$ ($72 \pm 10^\circ\text{F}$) is recommended for quality control.

8.2 *Test Conditions*—Conduct tests in the standard laboratory atmosphere of $23 \pm 2^\circ\text{C}$ ($73.4 \pm 3.6^\circ\text{F}$) and $50 \pm 5\%$