



Designation: D2919 – 01 (Reapproved 2007)

Standard Test Method for Determining Durability of Adhesive Joints Stressed in Shear by Tension Loading¹

This standard is issued under the fixed designation D2919; the number immediately following the designation indicates the year of original adoption or, in the case of revision, the year of last revision. A number in parentheses indicates the year of last reapproval. A superscript epsilon (ϵ) indicates an editorial change since the last revision or reapproval.

This standard has been approved for use by agencies of the Department of Defense.

1. Scope

1.1 This test method covers data for assessing the durability of adhesive lap-shear joints while stressed in contact with air, air in equilibrium with certain solutions, water, aqueous solutions, or other environments at various temperatures.

1.2 *This standard does not purport to address all of the safety concerns, if any, associated with its use. It is the responsibility of the user of this standard to establish appropriate safety and health practices and determine the applicability of regulatory limitations prior to use.* Specific precautionary statements are given in 7.4.

1.3 The values stated in SI units are considered to be the standard. The values in parentheses are for information only.

2. Referenced Documents

2.1 *ASTM Standards:*²

D907 Terminology of Adhesives

D1002 Test Method for Apparent Shear Strength of Single-Lap-Joint Adhesively Bonded Metal Specimens by Tension Loading (Metal-to-Metal)

D1828 Practice for Atmospheric Exposure of Adhesive-Bonded Joints and Structures

D2294 Test Method for Creep Properties of Adhesives in Shear by Tension Loading (Metal-to-Metal)

D3165 Test Method for Strength Properties of Adhesives in Shear by Tension Loading of Single-Lap-Joint Laminated Assemblies

E4 Practices for Force Verification of Testing Machines

¹ This test method is under the jurisdiction of ASTM Committee D14 on Adhesives and is the direct responsibility of Subcommittee D14.80 on Metal Bonding Adhesives

Current edition approved Oct. 1, 2007. Published October 2007. Originally approved in 1971. Last previous edition approved in 2001 as D2919 – 01^{ε1}. DOI: 10.1520/D2919-01R07.

² For referenced ASTM standards, visit the ASTM website, www.astm.org, or contact ASTM Customer Service at service@astm.org. For *Annual Book of ASTM Standards* volume information, refer to the standard's Document Summary page on the ASTM website.

2.2 *ASTM Adjuncts:*

Durability Test Apparatus Drawings³

3. Terminology

3.1 *Definitions*—Definitions of terms in this test method may be found in Terminology D907.

4. Significance and Use

4.1 The combination of stress and moisture decreases the durability of most adhesive joints. Stresses in the presence of water or water vapor may cause some adhesive joints to fail at some small fraction of the stress required to break the dry joint. The time to failure for a given adhesive joint generally decreases with increasing stress, temperature, and relative humidity.

4.2 This test method may be used as an accelerated screening test for assessing the durability of adhesive joints. It may be used to measure durability of adhesive joints exposed outdoors or to environmental conditions experienced by adhesive joints in service. The tests may also be used to determine the effects of various surface preparations or substrates on durabilities of adhesive joints.

4.3 The durability performance of various adhesives may be compared by using this test method under uniform sets of conditions. To assess the overall durability of a given adhesive, lap-shear joints should be tested under a range of stress, relative humidity, and temperature. For a specific end use it may be possible to obtain the needed durability data using only one set of test conditions.

5. Apparatus

5.1 *Fixture*, as shown in Fig. 1,³ is required for this test method, although a fixture such as described in Test Method D2294 may also be suitable for the performance of this test.

³ Detailed working drawings for the construction of the durability test apparatus are available from ASTM International Headquarters. Order Adjunct No. ADJD2919. Original adjunct produced in 1980.

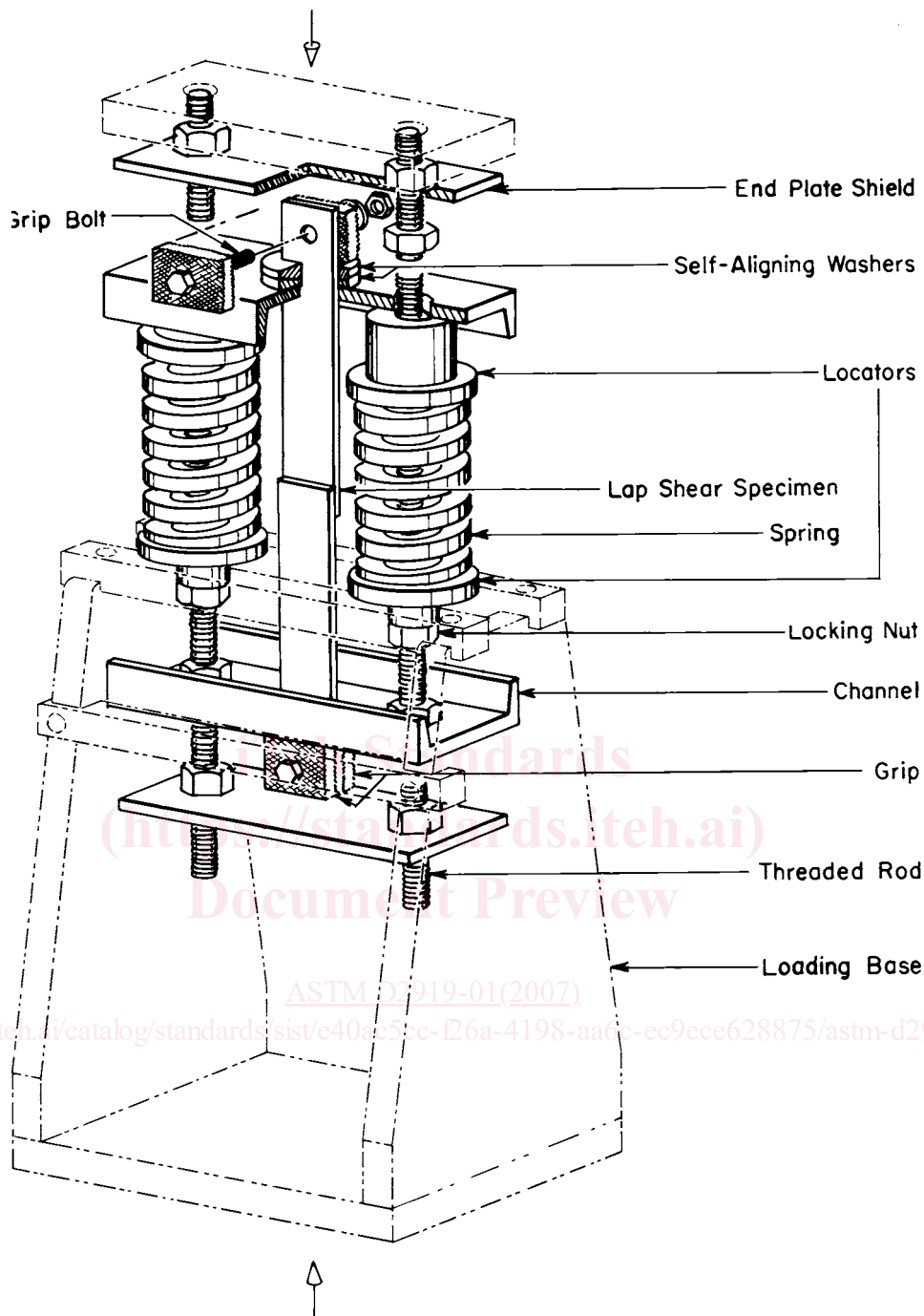

FIG. 1 Durability Test Apparatus

5.2 *Testing Machine*, or other suitable machine capable of applying measured compressive loads. Force measurements have an accuracy of $\pm 1\%$ of any reading when calibrated in compliance with Practices E4 requirements. Machine that is equipped with a suitable loading base as shown in Fig. 1, shall be used as a loading mechanism.

5.3 *Outdoor Weathering Racks (Standard)* are recommended (Practice D1828), but any stable frame may be used (for example, galvanized pipe or painted steel channel). No other special apparatus is required for outdoor tests.

6. Test Specimens

6.1 The successful use of this test method depends on preparing good quality lap-shear joints. The test joints must be prepared carefully in accordance with the adhesive manufacturer's directions or in accordance with some other specified set of conditions agreed upon between the manufacturer and the purchaser. It is recommended that the test joints be prepared in accordance with Test Method D1002, except that the dimensions of the test specimens shall be as shown in Fig. 2.