



Designation: D 4506 – 90 (Reapproved 1995)

AMERICAN SOCIETY FOR TESTING AND MATERIALS
100 Barr Harbor Dr., West Conshohocken, PA 19428
Reprinted from the Annual Book of ASTM Standards. Copyright ASTM

Standard Test Method for Determining the In Situ Modulus of Deformation of Rock Mass Using a Radial Jacking Test¹

This standard is issued under the fixed designation D 4506; the number immediately following the designation indicates the year of original adoption or, in the case of revision, the year of last revision. A number in parentheses indicates the year of last reapproval. A superscript epsilon (ϵ) indicates an editorial change since the last revision or reapproval.

1. Scope

1.1 This test method is used to determine the in situ modulus of deformation of rock mass by subjecting a test chamber of circular cross section to uniformly distributed radial loading; the consequent rock displacements are measured, from which elastic or deformation moduli may be calculated. The anisotropic deformability of the rock can also be measured and information on time-dependent deformation may be obtained.

1.2 This test method is based upon the procedures developed by the U.S. Bureau of Reclamation featuring long extensometers (1)². An alternative procedure is also available and is based on a reference bar (2).

1.3 Application of the test results is beyond the scope of this test method, but may be an integral part of some testing programs.

1.4 The values stated in inch-pound units are to be regarded as the standard.

1.5 *This standard does not purport to address all of the safety concerns, if any, associated with its use. It is the responsibility of the user of this standard to establish appropriate safety and health practices and determine the applicability of regulatory limitations prior to use.*

2. Referenced Documents

2.1 ASTM Standards:

D 653 Terminology Relating to Soil, Rock, and Contained Fluids³

D 4403 Practice for Extensometers Used in Rock³

3. Terminology

3.1 Definitions:

3.1.1 *deformation*—change in shape or size (from Terminology D 653) (see 3.2.1).

3.1.2 *modulus of deformation*—the ratio of stress to strain for a material under given loading conditions; numerically

¹ This test method is under the jurisdiction of ASTM Committee D-18 on Soil and Rock and is the direct responsibility of Subcommittee D18.12 on Rock Mechanics.

Current edition approved May 25, 1990. Published July 1990. Originally published as D 4506 – 85. Last previous edition D 4506 – 85.

² The **boldface** numbers in parentheses refer to the list of references appended to this standard.

³ *Annual Book of ASTM Standards*, Vol 04.08.

equal to the slope of the tangent or the secant of a stress-strain curve. The use of the term *modulus of elasticity* is recommended for materials that deform in accordance with Hooke's law; the term *modulus of deformation* for materials that deform otherwise (from Terminology D 653).

3.2 Definitions of Terms Specific to This Standard:

3.2.1 *deformation*—the change in the diameter of the excavation in rock (test chamber).

4. Summary of Test Method

4.1 A circular test chamber is excavated and a uniformly distributed pressure is applied to the chamber surfaces by means of flat jacks positioned on a reaction frame. Rock deformation is measured by extensometers placed in boreholes perpendicular to the chamber surfaces. Pressure is measured with a standard hydraulic transducer. During the test, the pressure is cycled incrementally and deformation is read at each increment. The modulus is then calculated. To determine time-dependent behavior, the pressure is held constant and deformation is observed over time.

5. Significance and Use

5.1 Using this test method, a volume of rock large enough to take into account the influence of discontinuities on the properties of the rock mass is loaded. The test should be used when values are required which represent the true rock mass properties more closely than can be obtained through less expensive uniaxial jacking tests or other procedures.

6. Apparatus

6.1 *Chamber Excavation Equipment*—This includes drilling and “smooth wall” blasting equipment or mechanical excavation equipment capable of producing typically a 9-ft (3-m) diameter tunnel with a length about three times that dimension.

6.2 *Concreting Equipment*—Concreting materials and equipment for lining the tunnel, together with strips of weak jointing materials for segmenting the lining.

6.3 *Reaction Frame*—The reaction frame shall be comprised of steel rings of sufficient strength and rigidity to resist the force applied by flat jacks, as depicted in Fig. 1. For load application by flat jacks, the frame must be provided with smooth surfaces; hardwood planks are usually inserted between the flat jacks and the metal rings.

6.4 *Loading Equipment*, to apply a uniformly distributed

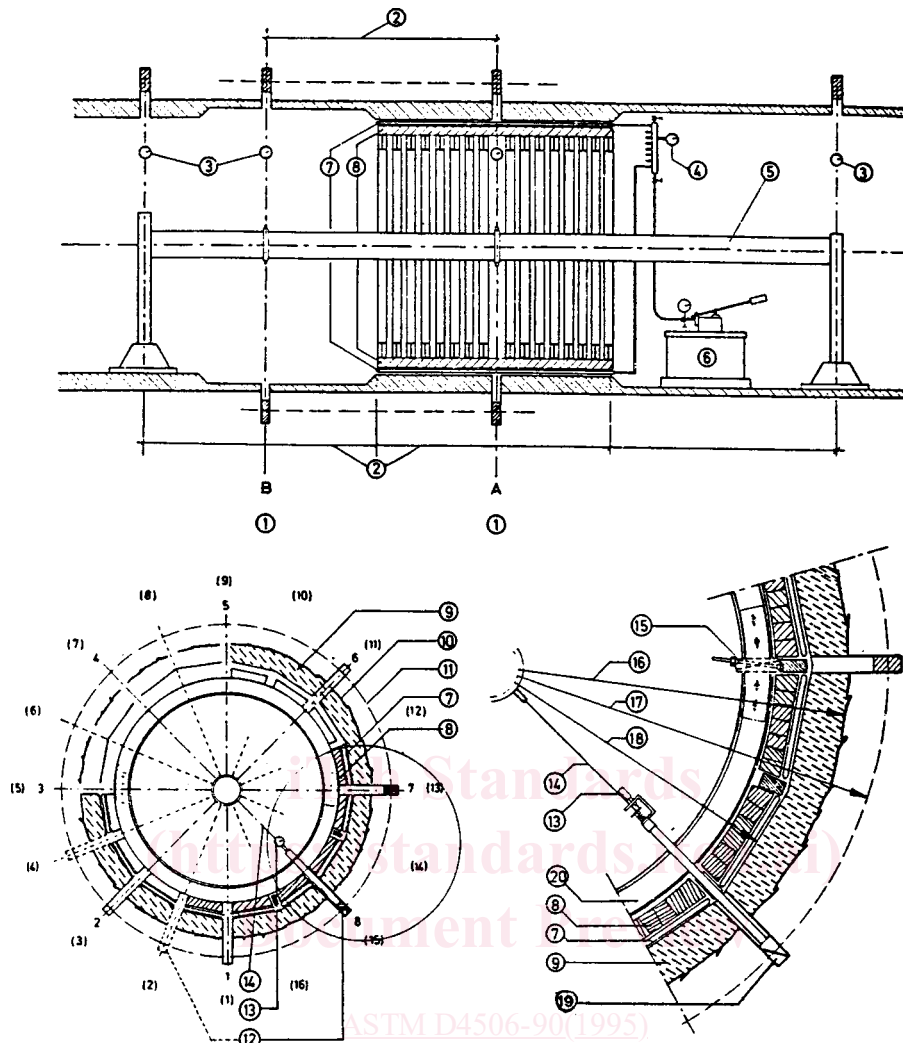

1. Measuring profile. 2. Distance equal to the length of active loading. 3. Control extensometer. 4. Pressure gage. 5. Reference beam. 6. Hydraulic pump. 7. Flat jack. 8. Hardwood lagging. 9. Shotcrete. 10. Excavation diameter. 11. Measuring diameter. 12. Extensometer drillholes. 13. Dial gage extensometer. 14. Steel rod. 15. Expansion wedges. 16. Excavation radius. 18. Inscribed Circle. 19. Rockbolt anchor. 20. Steel ring.

FIG. 1 Radial Jacking Test

radial pressure to the inner face of the concrete lining, including:

6.4.1 *Hydraulic Pump*, with all necessary hoses, connectors, and fluid, capable of applying the required pressure and of holding this pressure constant to within 5 % over a period of at least 24 h.

6.4.2 *Flat Jacks*, used for load application (Fig. 1), of a practicable width and of a length equal at least to the diameter of the tunnel (9 ft (3m)). The jacks should be designed to load the maximum of the full circumference of the lining with sufficient separation to allow displacement measurements, and should have a bursting pressure and travel consistent with the anticipated loads and displacements. Stainless steel flat jacks in effective contact with 90 % of the area are recommended, with the maximum pressure capacity twice the design pressure.

6.5 *Load Measuring Equipment*—Load measuring equipment shall consist of one or more hydraulic pressure gages or transducers of suitable range, capable of measuring the applied pressure with an accuracy better than $\pm 2\%$. Measurements are usually made by means of mechanical gages. Particular care is

required to guarantee the reliability of electric transducers and recording equipment, when used.

6.6 *Displacement Measuring Equipment*—Displacement measuring equipment to monitor rock movements radial to the tunnel must have a precision better than 0.01 mm. Multiple-position (six anchor points) extensometers in accordance with Practice D 4403 should be used. The directions of measurement should be normal to the axis of the tunnel. Measurements of movement should be related to reference anchors rigidly secured in rock, well away from the influence of the loaded zone. The multiple-position extensometers should have the deepest anchor as a reference situated at least 3 test-chamber diameters from the chamber lining.

7. Personnel Qualification and Equipment Calibration

7.1 All personnel involved in performing the test, including the technicians and test supervisor, shall be formally prequalified under the quality assurance procedures established as part of the overall testing program.

7.2 The compliance of all equipment and apparatus with the

performance specifications in Section 6 shall be verified. Performance verification is generally done by calibrating the equipment and measurement systems. Calibration and documentation shall be accomplished in accordance with standard quality assurance procedures.

8. Procedure

8.1 Test Chamber:

8.1.1 Select the test chamber location taking into consideration the rock conditions, particularly the orientation of the rock mass elements such as joints, bedding, and foliation in relation to the orientation of the proposed tunnel or opening for which results are required.

8.1.2 Excavate the test chamber by smooth (presplit) blasting to the required diameter of 9 ft (3 m), with a length equal to at least three diameters.

8.1.3 Record the geology of the chamber and specimens taken for index testing, as required. Core and log all instrumentation holes as follows:

8.1.3.1 *Cored Boreholes*—Drill the boreholes using diamond core techniques. Continuous core shall be obtained.

8.1.3.2 *Core Logged*—Completely log the recovered core, with emphasis on fractures and other mechanical nonhomogeneities.

8.1.4 Accurately mark out and drill the extensometer holes, ensuring no interference between loading and measuring systems. Install six-point extensometers and check the equipment. Place two anchors deep beyond the tunnel influence, appropriately spacing the other four anchors as close to the surface of the tunnel as possible.

8.1.5 Assemble the reaction frame and loading equipment.

8.1.6 Line the chamber with concrete to fill the space between the frame and the rock.

8.2 Loading:

8.2.1 Perform the test with at least three loading and unloading cycles, a higher maximum pressure being applied at each cycle. Typically, the maximum pressure applied is 1000 psi (7 MPa), depending on expected loads.

8.2.2 For each cycle, increase the pressure at an average rate of 100 psi/min (0.7 MPa/min) to the maximum for the cycle, taking not less than 10 intermediate sets of load-displacement readings in order to define a set of pressure-displacement curves (see Fig. 2). The automation of data recording is recommended.

8.2.3 On reaching the maximum pressure for the cycle, hold

the pressure constant for 10 min. Complete each cycle by reducing the pressure to near zero at the same average rate, taking a further three sets of pressure-displacement readings.

8.2.4 For the final cycle, hold the maximum pressure constant for 24 h to evaluate creep. Complete the cycle by unloading in stages, taking readings of pressure and corresponding displacements similar to the loading cycle.

9. Calculation

9.1 Correct the applied load values to give an equivalent distributed pressure, p_1 , on the test chamber lining, as follows:

$$p_1 = \frac{\sum b}{2 \cdot \pi \cdot r_1} p_m \tag{1}$$

where:

p_1 = distributed pressure on the lining at r_1 , psi (MPa),

r_1 = radius, ft (m),

p_m = pressure in the flat jacks, psi (MPa), and

b = flat jack width (see Fig. 3), ft (m).

9.1.1 Calculate the equivalent pressure p_2 at a “measuring radius” r_2 just beneath the lining; this radius being outside the zone of irregular stresses beneath the flat jacks and the lining and loose rock (see Fig. 3).

$$P_2 = \frac{r_1}{r_2} \cdot P_1 = \frac{\sum b}{2 \cdot \pi \cdot r_2} \cdot P_m \tag{2}$$

$$P_m \sum b = P_1 \cdot 2 \cdot \pi \cdot r_1 \cdot \pi$$

$$P_1 = \frac{P_m \sum b}{2 \cdot \pi \cdot r_1}$$

$$P_2 = P_1 \frac{r_1}{r_2}$$

9.2 Superposition is only strictly valid for elastic deformations but also gives a good approximation if the rock is

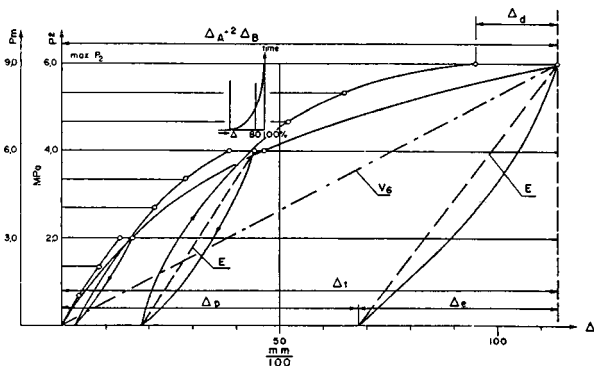

FIG. 2 Typical Graph of Applied Pressure Versus Displacement

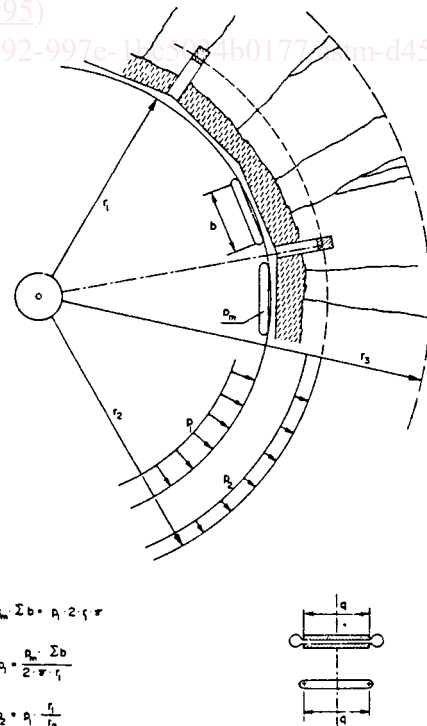

FIG. 3 Scheme of Loading Showing Symbols Used in the Calculations