Bicycle tyres and rims —

**Part 2:
Rims**

*Pneumatiques et jantes pour cycles —
Partie 2: Jantes*

**iTeh STANDARD PREVIEW
(standards.iteh.ai)**

[ISO 5775-2:2015](https://standards.iteh.ai/catalog/standards/sist/a59e1583-add3-4fe5-8ae2-4f21cb1e5055/iso-5775-2-2015)

<https://standards.iteh.ai/catalog/standards/sist/a59e1583-add3-4fe5-8ae2-4f21cb1e5055/iso-5775-2-2015>



iTeh STANDARD PREVIEW
(standards.iteh.ai)

ISO 5775-2:2015

<https://standards.iteh.ai/catalog/standards/sist/a59e1583-add3-4fe5-8ae2-4f21cb1e5055/iso-5775-2-2015>



COPYRIGHT PROTECTED DOCUMENT

© ISO 2015, Published in Switzerland

All rights reserved. Unless otherwise specified, no part of this publication may be reproduced or utilized otherwise in any form or by any means, electronic or mechanical, including photocopying, or posting on the internet or an intranet, without prior written permission. Permission can be requested from either ISO at the address below or ISO's member body in the country of the requester.

ISO copyright office
Ch. de Blandonnet 8 • CP 401
CH-1214 Vernier, Geneva, Switzerland
Tel. +41 22 749 01 11
Fax +41 22 749 09 47
copyright@iso.org
www.iso.org

Contents

	Page
Foreword	iv
1 Scope	1
2 Symbols and abbreviated terms	1
3 General requirements	1
3.1 Rim contour	1
3.2 Rim valve hole	2
3.3 Specific requirements	2
4 Straight side rims	2
4.1 Rim contour	2
4.2 Rim diameter	2
4.3 Designation and marking	2
5 Hooked bead rims	5
5.1 Rim contours	5
5.2 Rim diameters and circumferences	5
5.3 Designation and marking	6
6 Crotchet type rims	7
6.1 Rim contours	7
6.2 Rim diameters	7
6.3 Designation and marking	7
Annex A (informative) Methods for measuring and gauging bicycle rim dimensions	10

ITeH STANDARD PREVIEW
 (standards.iteh.ai)

[ISO 5775-2:2015](https://standards.iteh.ai/catalog/standards/sist/a59e1583-add3-4fe5-8ae2-4f21cb1e5055/iso-5775-2-2015)

<https://standards.iteh.ai/catalog/standards/sist/a59e1583-add3-4fe5-8ae2-4f21cb1e5055/iso-5775-2-2015>

Foreword

ISO (the International Organization for Standardization) is a worldwide federation of national standards bodies (ISO member bodies). The work of preparing International Standards is normally carried out through ISO technical committees. Each member body interested in a subject for which a technical committee has been established has the right to be represented on that committee. International organizations, governmental and non-governmental, in liaison with ISO, also take part in the work. ISO collaborates closely with the International Electrotechnical Commission (IEC) on all matters of electrotechnical standardization.

The procedures used to develop this document and those intended for its further maintenance are described in the ISO/IEC Directives, Part 1. In particular the different approval criteria needed for the different types of ISO documents should be noted. This document was drafted in accordance with the editorial rules of the ISO/IEC Directives, Part 2 (see www.iso.org/directives).

Attention is drawn to the possibility that some of the elements of this document may be the subject of patent rights. ISO shall not be held responsible for identifying any or all such patent rights. Details of any patent rights identified during the development of the document will be in the Introduction and/or on the ISO list of patent declarations received (see www.iso.org/patents).

Any trade name used in this document is information given for the convenience of users and does not constitute an endorsement.

For an explanation on the meaning of ISO specific terms and expressions related to conformity assessment, as well as information about ISO's adherence to the WTO principles in the Technical Barriers to Trade (TBT) see the following URL: [Foreword - Supplementary information](#)

The committee responsible for this document is ISO/TC 31, *Tyres, rims and valves*, Subcommittee SC 10, *Cycle, moped, motorcycle tyres and rims*.

This third edition cancels and replaces the second edition (ISO 5775-2:1996), which has been technically revised.

It also incorporates the Amendment, ISO 5775-2:1996/Amd 1:2001.

ISO 5775 consists of the following parts, under the general title *Bicycle tyres and rims*:

- *Part 1: Tyre designations and dimensions*
- *Part 2: Rims*

[Annex A](#) of this part of ISO 5775 is for information only.

This corrected version of ISO 5775-2:2015 incorporates the following corrections plus other minor editorial modifications.

Figures 3 and A.3 have been corrected. Dimension G has been adjusted to the solid line D1.

Bicycle tyres and rims —

Part 2: Rims

1 Scope

This part of ISO 5775 specifies rim dimensions for bicycle tyres: it gives only those rim contour dimensions necessary for tyre mounting and to fit the tyre on the rim.

ISO 5775-1 covers designations and dimensions for tyres.

ISO 5775-2 covers straight side (SS) rims, hooked bead type (HB) rims and crotchet type (C) rims.

2 Symbols and abbreviated terms

The following symbols are used in this part of ISO 5775:

A	Rim width
D	Specified rim diameter
D_1	Measured rim diameter
D_2	External diameter
D_m	Measuring mandrel diameter
G	Flange height
H, H_1	Unobstructed minimum depth above rim base with rim tape fitted to permit tyre fitment
L	Theoretical tape length
L_1	Well width above rim tape
P	Bead seat width
R_1, R_2	Flange radius
R_4	Well top radius
W	Measuring tape width

3 General requirements

3.1 Rim contour

The rim shall have a smooth contour, free of sharp edges, on the side of the tyre.

3.2 Rim valve hole

The rim valve hole shall be centred on the bottom of the rim well. On the tyre side, the edges have to be rounded or chamfered. On the hub side, the edges shall be free from burrs which could damage the valve.

3.3 Specific requirements

Designation and dimensions for straight side rims, hooked bead type rims and crotchet type rims are given in [Clauses 4, 5 and 6](#) respectively.

Width and thickness of rim base protection shall be chosen in such a way as to guarantee the complete covering of the spoke heads and spoke holes during use, as well as a stable lateral fit, and to permit satisfactory fitting of the tyre and the tube.

4 Straight side rims

4.1 Rim contour

Dimensions and tolerances of straight side (SS) rims shall be given in [Figure 1](#) and [Table 1](#)

Straight side rims are to be used only with non-foldable tyres (rigid bead tyres).

4.2 Rim diameter

The nominal rim diameter code, specified rim diameters and measuring rim diameters for straight side (SS) rims has to be given in [Figure 1](#) and [Table 2](#).

4.3 Designation and marking

A straight side (SS) rim shall be designated by its nominal rim diameter code and its nominal width code, optionally preceded by "SS" for straight side.

EXAMPLE SS 400 × 20

Dimensions in millimetres

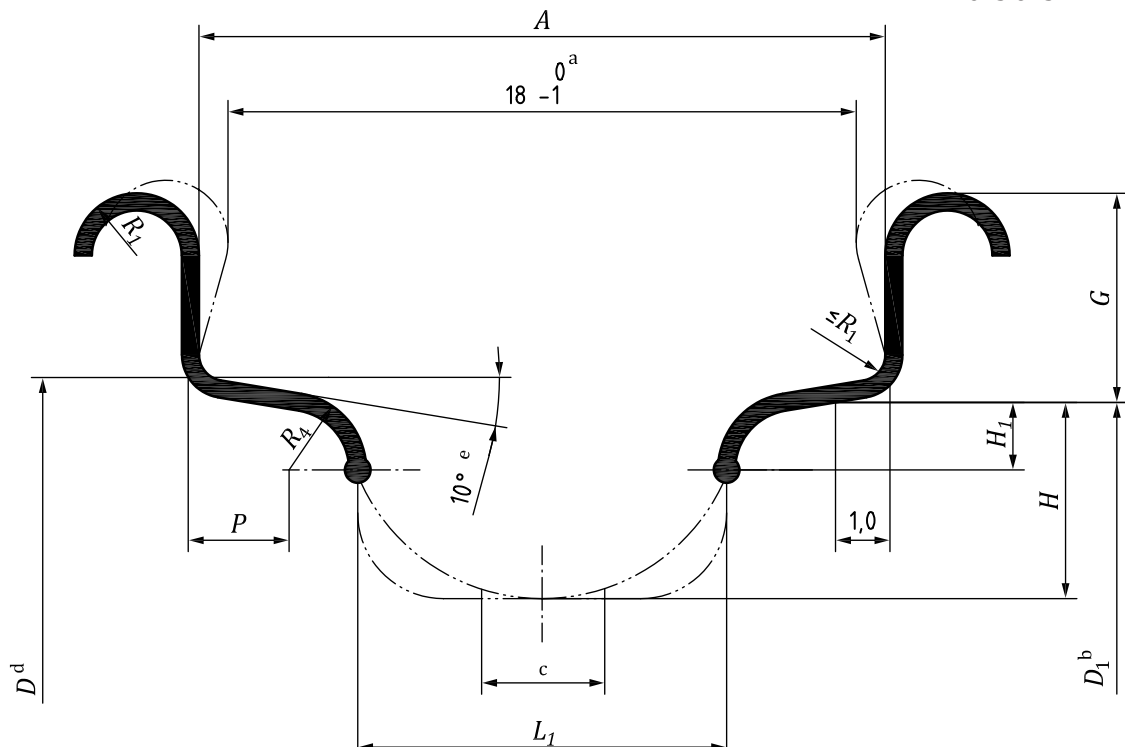

iTeh STANDARD PREVIEW
(standards.iteh.ai)

Key

- a 18⁰₋₁ (Rim 18 only).
- b Measuring rim diameter.
- c Valve holes 6,2^{+0,3/+0}; 8,3^{+0,3/+0}.
- d Specified rim diameter.
- e Allowed 5° to 15° (5° to 25° in case of rolled rims with nominal rim diameter 400 and smaller).

Figure 1 — Straight side rims

Table 1 — Dimensions of straight side rims

Dimensions in millimetres

Width code	A ±1	G ±0,5	H ₁ ^{a,b}		L ₁ ^b min	P min	R ₁ min	R ₄ min
			min	max				
16	16	5,5	1,8	6	9	1,5	1	1,5
18 ^c	18	6,5	1,8	6	10	1,8	1,5	1,5
20	20	6,5	2	6,5	11	2	1,8	1,5
22	22	6,5	3	7,5	11	2,2	1,8	2

a It is recommended that the contour of rims having a specified diameter below 400 mm should have well depth H₁ 1 mm deeper.

b The dimension H₁, in conjunction with dimension L₁, defines a minimum unobstructed space above the rim base and the nipple heads with the rim base protective flap fitted to permit satisfactory tyre fitment. The dimension H₁ is to be varied as the discretion of rim manufacturers to achieve the above objective.

c Previously known as rim with code 17.

Table 1 (continued)

Width code	A ±1	G ±0,5	H ₁ ^{a,b}		L ₁ ^b min	P min	R ₁ min	R ₄ min
			min	max				
24	24	7	3	7,5	11	3	2	2,5
27	27	7,5	3,5	8	14	3,5	2,5	2,5
30,5	30,5	8	3,5	8	14	3,5	2,5	2,5

^a It is recommended that the contour of rims having a specified diameter below 400 mm should have well depth H₁ 1 mm deeper.

^b The dimension H₁, in conjunction with dimension L₁, defines a minimum unobstructed space above the rim base and the nipple heads with the rim base protective flap fitted to permit satisfactory tyre fitment. The dimension H₁, is to be varied as the discretion of rim manufacturers to achieve the above objective.

^c Previously known as rim with code 17.

Table 2 — Specified and measuring ring rim diameters for straight side rims and crotchet type rims

Dimensions in millimetres

Nominal diameter code	Specified rim diameter D	Measuring rim diameter D ₁ ± 0,5 ^a
194	194,2	193,85
203	203,2	202,85
222	222,2	221,85
239	239,4	239,05
248	247,6	247,25
251	250,8	250,45
279	279,2	278,85
288	287,8	287,45
298	298,4	298,05
305	304,7	304,35
317	317,0	316,65
330	329,8	329,45
337	336,6	336,25
340	339,6	339,25
349	349,2	348,85
355	355,0	354,65
357	357,1	356,75
369	368,6	368,25
381	380,9	380,55
387	386,6	386,25
390	389,6	389,25
400	400,1	399,75
406	405,6	405,25
419	418,6	418,25
428	428,1	427,75
432	431,6	431,25
438	437,9	437,55

^a The tolerance on the measured bead seat circumference (p × measuring rim diameter) is ±1,5mm.

Table 2 (continued)

Nominal diameter code	Specified rim diameter D	Measuring rim diameter $D_1 \pm 0,5^a$
440	439,9	439,55
451	450,8	450,45
457	457,0	456,65
484	484,0	483,65
489	488,6	488,25
490	490,2	489,85
498	497,5	497,15
501	501,3	500,95
507	507,3	506,95
520	520,2	519,85
531	530,6	530,25
534	533,5	533,15
540	539,6	539,25
541	540,8	540,45
547	546,5	546,15
559	558,8	558,45
565	564,9	564,55
571	571,0	570,65
584	583,9	583,55
590	590,2	589,85
597	597,2	596,85
609	609,2	608,85
622	622,3	621,95
630	629,7	629,35
635	634,7	634,35
642	641,7	641,35

a The tolerance on the measured bead seat circumference ($p \times$ measuring rim diameter) is $\pm 1,5$ mm.

The mandrel diameter ($D_m \begin{smallmatrix} +0 \\ -0,05 \end{smallmatrix}$) related to the First Method is equal to the measuring rim diameter D_1 . The theoretical tape length, including the maximum tolerance on the bead set circumference, can be computed from $L = \pi (D_1 + 0,3) + 2,0$ and is related to the flat tape at 20 °C (See A.4).

5 Hooked bead rims

5.1 Rim contours

Dimensions and tolerances of hooked bead (HB) rims shall be as given in [Figure 2](#) and [Table 3](#).

5.2 Rim diameters and circumferences

The nominal rim diameter code, specified rim diameters and measuring circumferences for hooked bead (HB) rims shall be as given in [Figure 2](#) and [Table 4](#).

5.3 Designation and marking

A hooked bead (HB) rim shall be designated by its nominal rim diameter code and its nominal width code, preceded by "HB" for hooked bead.

EXAMPLE HB 422 × 25

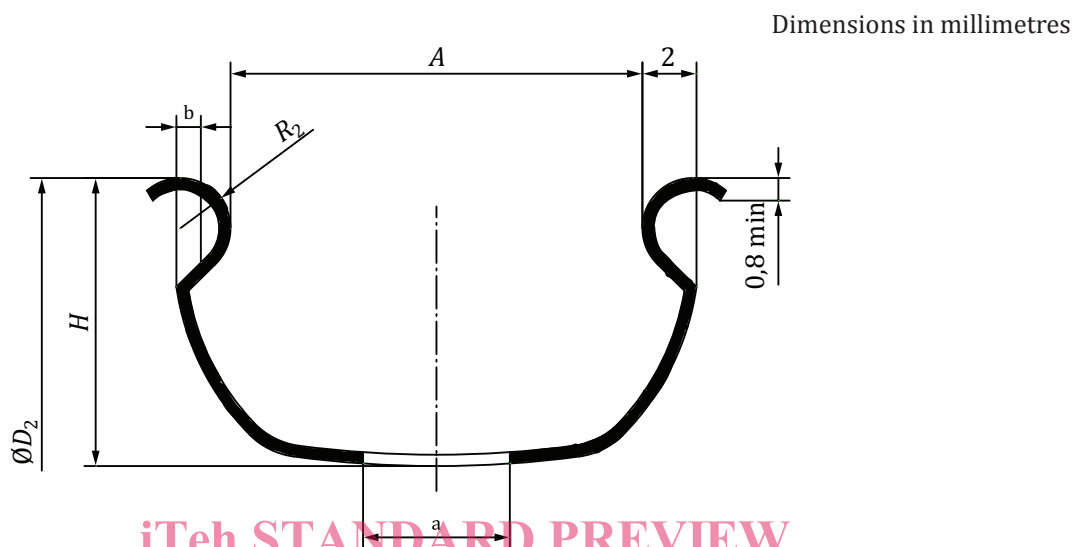

Key

- a Valve hole.
- b Optional opening not to exceed 1 mm.

ISO 5775-2:2015
<https://standards.iteh.ai/catalog/standards/sist/a59e1583-add3-4fe5-8ae2-421eb5615645-5775-2-2015>

Figure 2 — Hooked bead rims

Table 3 — Dimensions of hooked bead rims

Dimensions in millimetres

Nominal rim width	A ±1	H min	R ₂ ±0,5	R ₇ min
20	20	13	2	30
25	25	14	2	50
27	27	15	2	70

Table 4 — Specified rim diameters and circumferences for hooked bead rims

Dimensions in millimetres

Nominal rim diameter code	Specified rim diameter D	Specified rim circumference, π D ±2,5
HB270	269,9	847,9
HB321	320,7	1 007,5
HB372	371,5	1 167,1
HB422	422,3	1 326,7
HB459	458,8	1 441,4

HB denotes hooked bead rim; the number following HB is the rim code.

Table 4 (continued)

Nominal rim diameter code	Specified rim diameter <i>D</i>	Specified rim circumference, πD $\pm 2,5$
HB473	473,1	1 486,3
HB510	509,6	1 601
HB524	523,9	1 645,9
HB560	560,4	1 760,6
HB575	574,7	1 805,5
HB611	611,2	1 920,1

HB denotes hooked bead rim; the number following HB is the rim code.

6 Crotchet type rims

6.1 Rim contours

Dimensions and tolerances of crotchet type (C) rims shall be as given in [Figure 3](#) and [Table 5](#).

Crotchet type rims shall be used with rigid and foldable bead tyres.

6.2 Rim diameters

The nominal rim diameter code, specified rim diameters and measuring rim diameters for crotchet type (C) rims shall be given in [Figure 3](#) and [Table 2](#).

6.3 Designation and marking

A crotchet type (C) shall be designated by its nominal rim diameter code and its nominal width code, followed by "C" for crotchet type.

EXAMPLE 622 × 13C