



SLOVENSKI STANDARD

SIST EN 12855:2004

01-junij-2004

Stroji za predelavo hrane – Rezalniki z vrtljivo posodo – Varnostne in higienske zahteve

Food processing machinery - Rotating bowl cutters - Safety and hygiene requirements

Nahrungsmittelmaschinen - Kutter mit umlaufender Schüssel - Sicherheits- und Hygieneanforderungen

Machines pour les produits alimentaires - Cutters a cuve tournante - Prescriptions relatives a la sécurité et a l'hygiene

SIST EN 12855:2004
<https://standards.iteh.ai/catalog/standards/sist/ce009749-b061-41e2-aa4a-d6391eb1c868/sist-en-12855-2004>

Ta slovenski standard je istoveten z: EN 12855:2003

ICS:

67.260

Tovarne in oprema za
živilsko industrijo

Plants and equipment for the
food industry

SIST EN 12855:2004

en

iTeh STANDARD PREVIEW
(standards.iteh.ai)

[SIST EN 12855:2004](#)

<https://standards.iteh.ai/catalog/standards/sist/ce009749-b061-41e2-aa4a-d6391eb1c868/sist-en-12855-2004>

ICS 67.250

English version

Food processing machinery - Rotating bowl cutters - Safety and hygiene requirements

Machines pour les produits alimentaires - Cutters à cuve
tournante - Prescriptions relatives à la sécurité et à
l'hygiène

Nahrungsmittelmaschinen - Kutter mit umlaufender
Schüssel - Sicherheits- und Hygieneanforderungen

This European Standard was approved by CEN on 2 July 2003.

CEN members are bound to comply with the CEN/CENELEC Internal Regulations which stipulate the conditions for giving this European Standard the status of a national standard without any alteration. Up-to-date lists and bibliographical references concerning such national standards may be obtained on application to the Management Centre or to any CEN member.

This European Standard exists in three official versions (English, French, German). A version in any other language made by translation under the responsibility of a CEN member into its own language and notified to the Management Centre has the same status as the official versions.

CEN members are the national standards bodies of Austria, Belgium, Czech Republic, Denmark, Finland, France, Germany, Greece, Hungary, Iceland, Ireland, Italy, Luxembourg, Malta, Netherlands, Norway, Portugal, Slovakia, Spain, Sweden, Switzerland and United Kingdom.

[SIST EN 12855:2004](https://standards.iteh.ai/catalog/standards/sist/ce009749-b061-41e2-aa4a-d6391eb1c868/sist-en-12855-2004)

<https://standards.iteh.ai/catalog/standards/sist/ce009749-b061-41e2-aa4a-d6391eb1c868/sist-en-12855-2004>



EUROPEAN COMMITTEE FOR STANDARDIZATION
COMITÉ EUROPÉEN DE NORMALISATION
EUROPÄISCHES KOMITEE FÜR NORMUNG

Management Centre: rue de Stassart, 36 B-1050 Brussels

Contents

page

Foreword.....	3
Introduction	4
1 Scope	5
2 Normative references	7
3 Terms and definitions.....	8
4 List of hazards.....	9
4.1 General.....	9
4.2 Mechanical hazards	9
4.3 Electrical hazards	11
4.4 Hydraulic hazards	11
4.5 Hazard from loss of stability.....	11
4.6 Noise hazard.....	11
4.7 Hazard from use of gases (N ₂ , CO ₂ and steam).....	11
4.8 Hazards from non-compliance with ergonomic principles	11
4.9 Hazards from non-compliance with hygiene principles	11
5 Safety requirements and/or measures	12
5.1 General.....	12
5.2 Mechanical hazards	12
5.3 Electrical Hazards	18
5.4 Hydraulic and pneumatic hazards.....	21
5.5 Hazard from loss of stability.....	21
5.6 Noise reduction.....	21
5.7 Hazard from use of gases (N ₂ , CO ₂ and steam).....	21
5.8 Ergonomic requirements	22
5.9 Hygiene and cleaning	22
6 Verification of safety requirements and/or safety measures	24
7 Information for use	25
7.1 General.....	25
7.2 Operating instructions	25
7.3 Training of operators.....	27
8 Marking	27
Annex A (normative) Common hazards for food processing machines and reduction requirements applicable to rotating bowl cutters	28
Annex B (normative) Noise test code for rotating bowl cutters (grade 2).....	30
Annex C (normative) Design principles to ensure cleanability of rotating bowl cutters.....	32
Annex ZA (informative) Relationship of this document with EC Directives.....	37
Bibliography	38

iTech STANDARD PREVIEW
(standards.itech.ai)

SIST EN 12855:2004
https://standards.itech.ai/catalog/standards/sist/ce009749-b061-41e2-a24a-d6391ab1e868/sist-en-12855-2004

Foreword

This document (EN 12855:2003) has been prepared by Technical Committee CEN/TC 153 "Food processing machinery - Safety and hygiene specifications", the secretariat of which is held by DIN.

This European Standard shall be given the status of a national standard, either by publication of an identical text or by endorsement, at the latest by February 2004, and conflicting national standards shall be withdrawn at the latest by February 2004.

This document has been prepared under a mandate given to CEN by the European Commission and the European Free Trade Association, and supports essential requirements of EU Directive(s).

For relationship with EU Directive(s), see informative annex ZA, which is an integral part of this document.

It is one of a series of standards which have been prepared for machines and equipment for meat processing in accordance with EN 1672-2.

Annexes A, B and C are normative parts of this standard, ZA is informative. This European Standard also contains a Bibliography.

According to the CEN/CENELEC Internal Regulations, the national standards organizations of the following countries are bound to implement this European Standard: Austria, Belgium, Czech Republic, Denmark, Finland, France, Germany, Greece, Hungary, Iceland, Ireland, Italy, Luxembourg, Malta, Netherlands, Norway, Portugal, Slovakia, Spain, Sweden, Switzerland and the United Kingdom.

SIST EN 12855:2004

<https://standards.iteh.ai/catalog/standards/sist/ce009749-b061-41e2-aa4a-d6391eb1c868/sist-en-12855-2004>

0 Introduction

This standard covers rotating bowl cutters with optional loading and unloading devices.

iTeh STANDARD PREVIEW
(standards.iteh.ai)

[SIST EN 12855:2004](https://standards.iteh.ai/catalog/standards/sist/en-12855-2004)

<https://standards.iteh.ai/catalog/standards/sist/en-12855-2004>

1 Scope

1.1 This European Standard specifies requirements for bowl cutters (see figure 1) used when stationary and positioned on the floor or at table height.

Bowl cutters are food machines used to process fresh or frozen meat, meat products, fish and vegetables in a rotating bowl. This is performed by means of vertical blades rotating around a nearly horizontal axis. This European Standard considers hazards arising from the design, operation, commissioning and maintenance of the rotating bowl cutters when used as intended by the manufacturer. The intended uses of the machines are described in clause 7 of this standard, 'Information for use.

This standard does not apply to household bowl cutters.

1.2 This standard only applies to machines which are manufactured after the date of issue of this standard.

1.3 This standard covers the following types of bowl cutters according to the diameter (D) or the volume (V) of the bowl:

— Type 1 bowl cutters

$$D \leq 700 \text{ mm or } 2 \text{ l} \leq V \leq 30 \text{ l}$$

— Type 2 bowl cutters

$$700 \text{ mm} < D \leq 1\,200 \text{ mm or } 30 \text{ l} < V \leq 120 \text{ l}$$

— Type 3 bowl cutters

$$D > 1\,200 \text{ mm or } V > 120 \text{ l}$$

iTeh STANDARD PREVIEW
(standards.iteh.ai)
<https://standards.iteh.ai/catalog/standards/sist/ce009749-b061-41e2-aa4a-d6391eb1c868/sist-en-12855-2004>
SIST EN 12855:2004

For type 2 and type 3 bowl cutters, loading devices are also covered in this standard.

Bowl cutters are constructed, for example, from a machine frame, a bowl, a set of cutting blades, a blade shaft, a blade cover, a noise cover, a loading and removal device, an associated drive and electrical, hydraulic and pneumatic components and also components for fumigating, vacuuming, heating and cooling according to machine type.

NOTE In preparing this standard it was assumed that the machine would be operated by trained personnel.

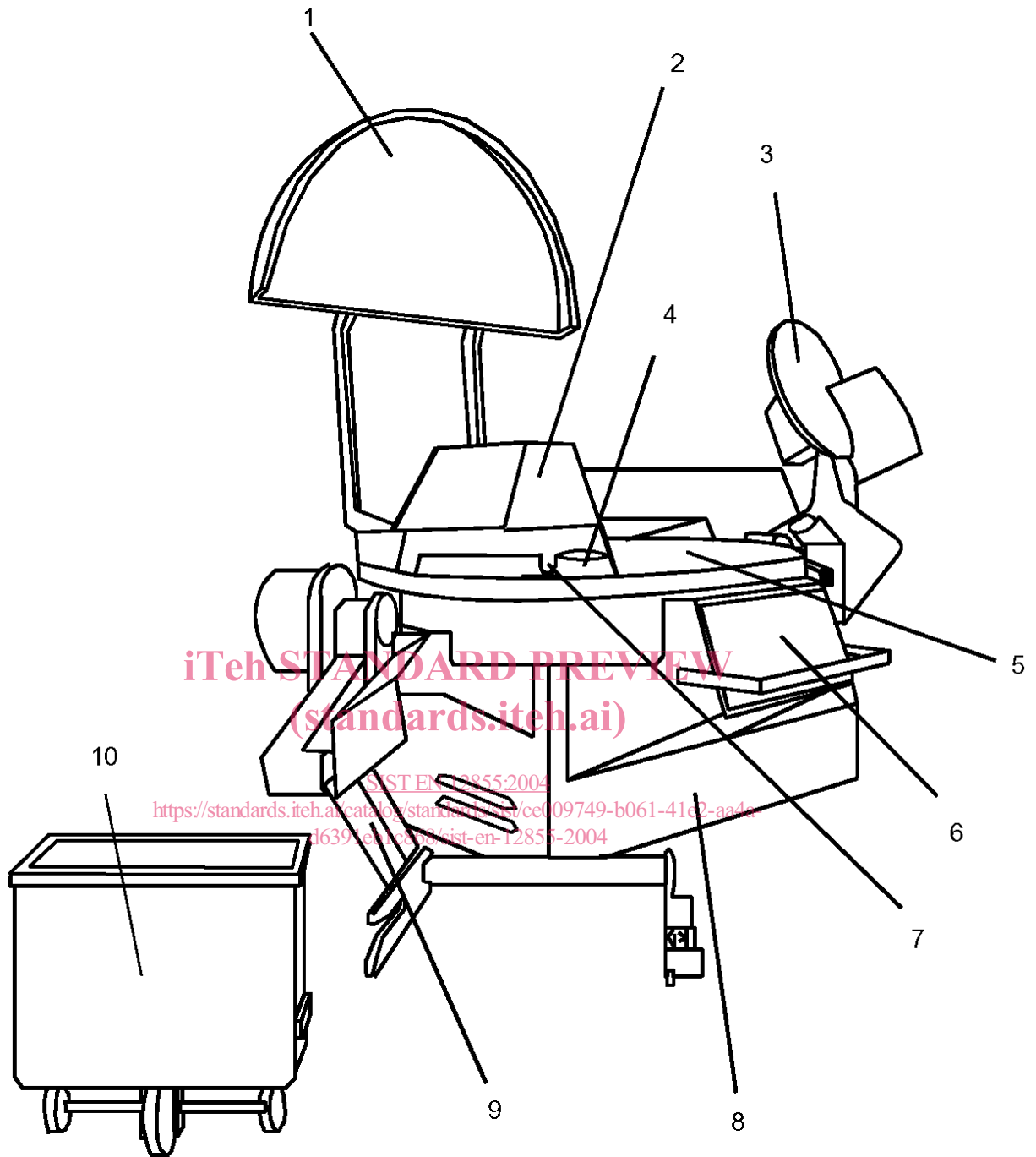

iTeh STANDARD PREVIEW
(standards.iteh.ai)

https://standards.iteh.ai/catalog/standards/sist/en-12855-2004/ce109749-b061-41e2-aada-16391e16391e/sist-en-12855-2004

Key

- | | | | |
|---|------------------|----|--|
| 1 | noise cover | 6 | control elements |
| 2 | blade cover | 7 | fixed safety hand device |
| 3 | unloading device | 8 | machine frame |
| 4 | mushroom | 9 | loading device |
| 5 | bowl | 10 | transport trolley is not part of the rotating bowl cutter covered by this standard |

Figure 1 — Elements of a bowl cutter, accessories

The fresh or deep-frozen material is fed manually or by means of a loading device into the bowl of the bowl cutter. On account of the rotation of the cutter bowl at different speeds of the blade shaft, the material is mixed with additives, size reduced or emulsified. This can also take place under vacuum, or when liquid nitrogen or carbon dioxide or steam is added, or when boiling takes place at the same time.

Bowl cutters do not operate in a continuous mode.

2 Normative references

This European Standard incorporates by dated or undated reference, provisions from other publications. These normative references are cited at the appropriate places in the text, and the publications are listed hereafter. For dated references, subsequent amendments to or revisions of any of these publications apply to this European Standard only when incorporated in it by amendment or revision. For undated references the latest edition of the publication referred to applies (including amendments).

EN 292-2:1991, *Safety of machinery - Basic concepts, general principles for design - Part 2: Technical principles and specifications*

EN 418, *Safety of machinery - Emergency stop equipment, functional aspects – Principles for design.*

EN 614-1:1995, *Safety of machinery - Ergonomic design principles - Part 1: Terminology and general principles*

EN 953:1997, *Safety of machinery - Guards - General requirements for the design and construction of fixed and movable guards*

EN 954-1:1996, *Safety of machinery - Safety related parts of control systems - Part 1: General principles for design.*

EN 982:1996, *Safety of machinery - Safety requirements for fluid power systems and their components – Hydraulics.*

EN 983:1996, *Safety of machinery - Safety requirements for fluid power systems and their components – Pneumatics.*

EN 1005-1, *Safety of machinery - Human physical performance - Part 1: Terms and Definitions.*

EN 1005-2, *Safety of machinery - Human physical performance - Part 2: Manual handling of machinery and component parts of machinery.*

EN 1005-3, *Safety of machinery - Human physical performance - Part 3: Recommended force limits for machinery operation.*

EN 1037:1995, *Safety of Machinery - Prevention of unexpected start-up.*

EN 1070:1998, *Safety of machinery – Terminology.*

EN 1088:1995, *Safety of machinery - Interlocking devices associated with guards - Principles for design and selection.*

EN 1672-2:1997, *Food processing machinery - Basic concepts - Part 2: Hygiene requirements.*

EN 60204-1:1997, *Safety of machinery - Electrical equipment of machines - Part 1: General requirements (IEC 60204-1:1997)*

EN 60529:1991, *Degrees of protection provided by enclosures (IP Code) (IEC 60529:1989).*

EN 61000-6-1, *Electromagnetic compatibility (EMC) - Part 6-1: Generic standards; Immunity for residential, commercial and light-industrial environments (IEC 61000-6-1:1997, modified)*

EN 61000-6-2, *Electromagnetic compatibility (EMC) - Part 6-2: Generic standards; Immunity for industrial environments (IEC 61000-6-2:1999, modified)*

EN 61000-6-3, *Electromagnetic compatibility (EMC) - Part 6-3: Generic standards; Emission standard for residential, commercial and light-industrial environments (IEC 61000-6-3:1996, modified)*

EN 61000-6-4, *Electromagnetic compatibility (EMC) - Part 6-4: Generic standards; Emission standard for industrial environments (IEC 61000-6-4:1997, modified)*

EN 12855:2003 (E)

EN ISO 3744, *Acoustics - Determination of sound power levels of noise sources using sound pressure - Engineering method in an essentially free field over a reflecting plane (ISO 3744:1994).*

EN ISO 4871, *Acoustics - Declaration and verification of noise emission values of machinery and equipment (ISO 4871:1996).*

EN ISO 11204:1995, *Acoustics- Noise emitted by machinery and equipment - Measurement of emission sound pressure levels at a work station and at other specified positions - Method requiring environmental corrections (ISO 11204:1995).*

3 Terms and definitions

For the purposes of this European Standard, the terms and definitions given in EN 1070:1998 and in EN 1672-2:1997 and the following terms and definitions apply.

3.1

unloading device

comprises a swivel arm with a rotating disc for emptying the bowl

3.2

container

a unit for holding ingredients to be processed and the product

3.3

loading device

a lift-tilt device for raising and tilting transport trolleys and containers

3.4

locking device

a device for fixing the transport trolley or container in the load bearing device

3.5

transport trolley

a travelling device for holding ingredients to be processed and products

3.6

fixed hand safety device

rigid strips integrated into the blade cover, which together with the mushroom cover the cutting set

3.7

noise cover

equipment for covering the part of the bowl, which is not covered by the blade cover, intended to decrease the noise emitted by the cutting set

3.8

machine frame

the structure on which the machine parts are mounted

3.9

blade

generally sickle-shaped and convex sharpened cutting inserts adapted to the bowl profile

3.10

cutting set

combination of blades which can be mounted on the blade shaft

3.11**blade cover**

movable cover over the cutting set and a portion of the bowl

3.12**blade shaft**

drive shaft for the cutting set

3.13**mushroom**

formation of the centre of the bowl, giving support for the blade cover and keeping the product travelling through the rotating blades

3.14**bowl**

container for ingredients or cut product

3.15**bowl volume**

volume of the bowl expressed in litres, (measured when filled with water to the maximum fill level)

3.16**vacuum boiling lid**

cover, required for production of certain products. It can replace the noise cover

iTeh STANDARD PREVIEW (standards.iteh.ai)

4 List of hazards**4.1 General**

[SIST EN 12855:2004](#)

This clause and annex A contain the hazards and hazardous situations as far as they are dealt with in this European Standard, identified by a risk assessment significant for this type of machinery and which require action identified to eliminate or reduce risk.

Before using this standard it is important to carry out a risk assessment of the rotating bowl cutter to check that it has the hazards identified in this clause.

4.2 Mechanical hazards

(See figure 2)

- Zone 1
 - Rotating blades under blade cover;
 - Cutting or severing hazards to fingers or hand;
- Zone 2
 - Zone between bowl and machine frame;
 - Drawing-in hazards to fingers or hand;
- Zone 3
 - Area of movement of loading device;
 - Crushing or shearing hazards to limbs or body;
- Zone 4
 - Area of movement of blade cover and/or noise cover and/or vacuum lid;
 - Crushing hazard to fingers or hands;

- Zone 5
 - Area of drive systems;
 - Severing or drawing-in hazard to upper limbs;
- Zone 6
 - Ejection of blades in the event of breakage;
 - Cutting or penetration hazards to body;
- Zone 7
 - Area of unloading device;
 - Crushing hazard to fingers or hands;
- Zone 8
 - Cleaning and maintenance of blades;
 - Cutting or severing hazards to fingers or hands.

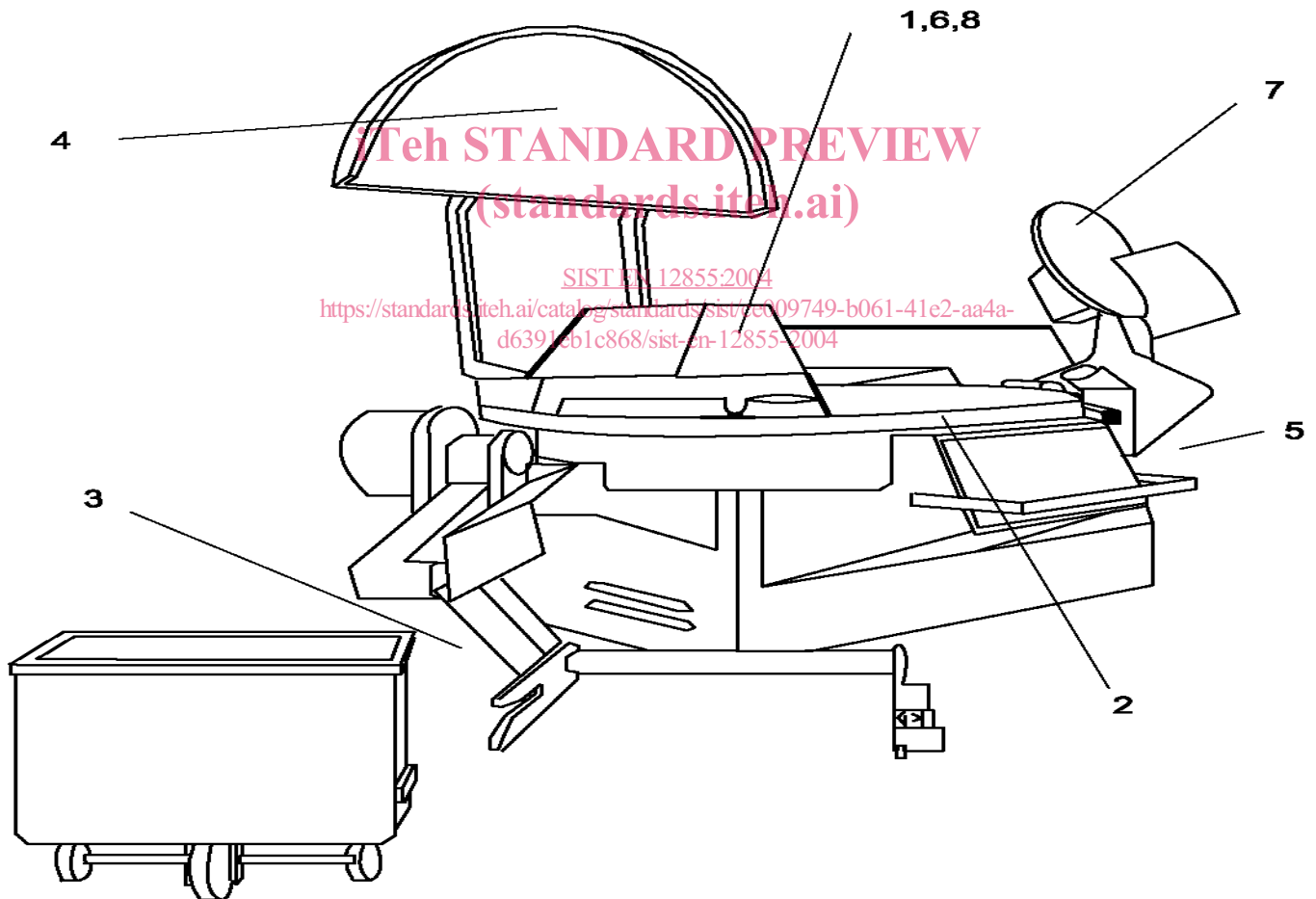

Key

1	zone 1	5	zone 5
2	zone 2	6	zone 6
3	zone 3	7	zone 7
4	zone 4	8	zone 8

Figure 2 — Danger areas of bowl cutters

4.3 Electrical hazards

4.3.1 Direct or indirect contact with live parts

Hazard of electric shock to the body, including the result of a malfunction.

4.3.2 Electrical components with insufficient safety level

Hazard of mechanical injury to the body, including the result of a malfunction.

4.4 Hydraulic hazards

Hazard to operator from ejection of high-pressure liquid.

4.5 Hazard from loss of stability

Impact or crushing hazard to the body, if machine or loading device topples over.

4.6 Noise hazard

Rotating bowl cutters may generate noise which can result in hearing damage, and in accidents due to interference with speech communication and in interference with the perception of acoustic signals.

4.7 Hazard from use of gases (N₂, CO₂ and steam)

Leakage of gases such as carbon dioxide (CO₂), nitrogen (N₂) or steam;

- Hazard of suffocation; [SIST EN 12855:2004](https://standards.iteh.ai/catalog/standards/sist/ce009749-b061-41e2-aa4a-16391eb1c868/sist-en-12855-2004)
- Hazard of burns, frostbite or scalding; <https://standards.iteh.ai/catalog/standards/sist/ce009749-b061-41e2-aa4a-16391eb1c868/sist-en-12855-2004>

4.8 Hazards from non-compliance with ergonomic principles

- Unhealthy posture or excessive physical effort;
- Inadequate consideration of the human anatomy of hand/arm or foot/leg during machine design;
- Hazard of physical damage to body.

4.9 Hazards from non-compliance with hygiene principles

- Microbial causes:
 - Hazard from foodstuff spoilage;
 - Hazard of damage to health of the consumer through food poisoning;
 - Hazard of infection of operator.
- Chemical causes:
 - Hazard (contamination) of foodstuff through residues of cleaning and disinfecting agents and hydraulic fluid;
 - Hazard of damage to health of the consumer;
 - Hazard of toxic or allergic reactions from operator;