

ETSI TS 129 510 V15.1.0 (2018-10)



**5G;
5G System;
Network function repository services;
Stage 3
(3GPP TS 29.510 version 15.1.0 Release 15)**

PRE-REVIEW
From STANARDS (15.1.0)
<https://standards.iteh.ai/en/standards/sist/dffd8c2b-6893-48a9-bc88-3725c6fda500/standards/TS-29-510-15.1.0-2018-10>



ReferenceRTS/TSGC-0429510vf10

Keywords5G

ETSI

650 Route des Lucioles
F-06921 Sophia Antipolis Cedex - FRANCE

Tel.: +33 4 92 94 42 00 Fax: +33 4 93 65 47 16

Siret N° 348 623 562 00017 - NAF 742 C
Association à but non lucratif enregistrée à la
Sous-Préfecture de Grasse (06) N° 7803/88

Important notice

The present document can be downloaded from:

<http://www.etsi.org/standards-search>

The present document may be made available in electronic versions and/or in print. The content of any electronic and/or print versions of the present document shall not be modified without the prior written authorization of ETSI. In case of any existing or perceived difference in contents between such versions and/or in print, the only prevailing document is the print of the Portable Document Format (PDF) version kept on a specific network drive within ETSI Secretariat.

Users of the present document should be aware that the document may be subject to revision or change of status.

Information on the current status of this and other ETSI documents is available at

<https://portal.etsi.org/TB/ETSIDeliverableStatus.aspx>

If you find errors in the present document, please send your comment to one of the following services:

<https://portal.etsi.org/People/CommiteeSupportStaff.aspx>

Copyright Notification

No part may be reproduced or utilized in any form or by any means, electronic or mechanical, including photocopying and microfilm except as authorized by written permission of ETSI.

The content of the PDF version shall not be modified without the written authorization of ETSI.

The copyright and the foregoing restriction extend to reproduction in all media.

© ETSI 2018.

All rights reserved.

DECT™, **PLUGTESTS™**, **UMTS™** and the ETSI logo are trademarks of ETSI registered for the benefit of its Members.

3GPP™ and **LTE™** are trademarks of ETSI registered for the benefit of its Members and of the 3GPP Organizational Partners.

oneM2M logo is protected for the benefit of its Members.

GSM® and the GSM logo are trademarks registered and owned by the GSM Association.

Intellectual Property Rights

Essential patents

IPRs essential or potentially essential to normative deliverables may have been declared to ETSI. The information pertaining to these essential IPRs, if any, is publicly available for **ETSI members and non-members**, and can be found in ETSI SR 000 314: *"Intellectual Property Rights (IPRs); Essential, or potentially Essential, IPRs notified to ETSI in respect of ETSI standards"*, which is available from the ETSI Secretariat. Latest updates are available on the ETSI Web server (<https://ipr.etsi.org/>).

Pursuant to the ETSI IPR Policy, no investigation, including IPR searches, has been carried out by ETSI. No guarantee can be given as to the existence of other IPRs not referenced in ETSI SR 000 314 (or the updates on the ETSI Web server) which are, or may be, or may become, essential to the present document.

Trademarks

The present document may include trademarks and/or tradenames which are asserted and/or registered by their owners. ETSI claims no ownership of these except for any which are indicated as being the property of ETSI, and conveys no right to use or reproduce any trademark and/or tradename. Mention of those trademarks in the present document does not constitute an endorsement by ETSI of products, services or organizations associated with those trademarks.

Foreword

This Technical Specification (TS) has been produced by ETSI 3rd Generation Partnership Project (3GPP).

The present document may refer to technical specifications or reports using their 3GPP identities, UMTS identities or GSM identities. These should be interpreted as being references to the corresponding ETSI deliverables.

The cross reference between GSM, UMTS, 3GPP and ETSI identities can be found under <http://webapp.etsi.org/key/queryform.asp>.

Modal verbs terminology

In the present document "**shall**", "**shall not**", "**should**", "**should not**", "**may**", "**need not**", "**will**", "**will not**", "**can**" and "**cannot**" are to be interpreted as described in clause 3.2 of the [ETSI Drafting Rules](#) (Verbal forms for the expression of provisions).

"**must**" and "**must not**" are **NOT** allowed in ETSI deliverables except when used in direct citation.

Contents

Intellectual Property Rights	2
Foreword.....	2
Modal verbs terminology.....	2
Foreword.....	7
Introduction	7
1 Scope	8
2 References	8
3 Definitions and abbreviations.....	9
3.1 Definitions	9
3.2 Abbreviations	9
4 Overview	9
5 Services Offered by the NRF	10
5.1 Introduction	10
5.2 Nnrf_NFManagement Service.....	10
5.2.1 Service Description.....	10
5.2.2 Service Operations	10
5.2.2.1 Introduction	10
5.2.2.2 NFRegister	11
5.2.2.2.1 General	11
5.2.2.2.2 NF (other than NRF) registration to NRF.....	11
5.2.2.2.3 NRF registration to another NRF	12
5.2.2.3 NFUpdate.....	12
5.2.2.3.1 General	12
5.2.2.3.2 NF Heart-Beat	13
5.2.2.4 NFDeregister.....	14
5.2.2.4.1 General	14
5.2.2.5 NFStatusSubscribe	14
5.2.2.5.1 General	14
5.2.2.5.2 Subscription to NF Instances in the same PLMN.....	15
5.2.2.5.3 Subscription to NF Instances in a different PLMN	15
5.2.2.6 NFStatusNotify	16
5.2.2.6.1 General	16
5.2.2.6.2 Notification from NRF in the same PLMN	16
5.2.2.6.3 Notification from NRF in a different PLMN.....	17
5.2.2.7 NFStatusUnSubscribe	17
5.2.2.7.1 General	17
5.2.2.7.2 Subscription removal in the same PLMN.....	17
5.2.2.7.3 Subscription removal in a different PLMN	17
5.3 Nnrf_NFDiscovery Service	18
5.3.1 Service Description.....	18
5.3.2 Service Operations	18
5.3.2.1 Introduction.....	18
5.3.2.2 NFDdiscover	19
5.3.2.2.1 General	19
5.3.2.2.2 Service Discovery in the same PLMN.....	19
5.3.2.2.3 Service Discovery in a different PLMN	19
5.3.2.2.4 Service Discovery with intermediate redirecting NRF.....	20
5.3.2.2.5 Service Discovery with intermediate forwarding NRF	21
5.4 OAuth2 Authorization Service	22
5.4.1 Service Description.....	22
5.4.2 Service Operations	22
5.4.2.1 Introduction.....	22
5.4.2.2 Access Token Request	22

5.4.2.2.1	General	22
6	API Definitions	23
6.1	Nnrf_NFManagement Service API	23
6.1.1	API URI	23
6.1.2	Usage of HTTP	23
6.1.2.1	General	23
6.1.2.2	HTTP Standard Headers	23
6.1.2.2.1	General	23
6.1.2.2.2	Content type	23
6.1.2.3	HTTP custom headers	24
6.1.2.3.1	General	24
6.1.3	Resources	24
6.1.3.1	Overview	24
6.1.3.2	Resource: nf-instances (Store)	25
6.1.3.2.1	Description	25
6.1.3.2.2	Resource Definition	25
6.1.3.2.3	Resource Standard Methods	25
6.1.3.2.3.1	GET	25
6.1.3.2.4	Resource Custom Operations	26
6.1.3.3	Resource: nf-instance (Document)	26
6.1.3.3.1	Description	26
6.1.3.3.2	Resource Definition	26
6.1.3.3.3	Resource Standard Methods	26
6.1.3.3.3.1	GET	26
6.1.3.3.3.2	PUT	27
6.1.3.3.3.3	PATCH	28
6.1.3.3.3.4	DELETE	28
6.1.3.4	Resource: subscriptions (Collection)	29
6.1.3.4.1	Description	29
6.1.3.4.2	Resource Definition	29
6.1.3.4.3	Resource Standard Methods	29
6.1.3.4.3.1	POST	29
6.1.3.5	Resource: subscription (Document)	30
6.1.3.5.1	Description	30
6.1.3.5.2	Resource Definition	30
6.1.3.5.3	Resource Standard Methods	30
6.1.3.5.3.1	DELETE	30
6.1.4	Custom Operations without associated resources	31
6.1.5	Notifications	31
6.1.5.1	General	31
6.1.5.2	NF Instance Status Notification	31
6.1.5.2.1	Description	31
6.1.5.2.2	Notification Definition	31
6.1.6	Data Model	32
6.1.6.1	General	32
6.1.6.2	Structured data types	33
6.1.6.2.1	Introduction	33
6.1.6.2.2	Type: NFProfile	34
6.1.6.2.3	Type: NFService	36
6.1.6.2.4	Type: DefaultNotificationSubscription	38
6.1.6.2.5	Type: IpEndPoint	38
6.1.6.2.6	Type: UdrInfo	38
6.1.6.2.7	Type: UdmInfo	38
6.1.6.2.8	Type: AusfInfo	39
6.1.6.2.9	Type: SupiRange	39
6.1.6.2.10	Type: IdentityRange	40
6.1.6.2.11	Type: AmfInfo	40
6.1.6.2.12	Type: SmfInfo	41
6.1.6.2.13	Type: UpfInfo	41
6.1.6.2.14	Type: SnsaiUpfInfoItem	41
6.1.6.2.15	Type: DnnUpfInfoItem	41

6.1.6.2.16	Type: SubscriptionData	42
6.1.6.2.17	Type: NotificationData	43
6.1.6.2.18	Type: NFRegistrationData	43
6.1.6.2.19	Type: NFSERVICEVersion	43
6.1.6.2.20	Type: PcfInfo	43
6.1.6.2.21	Type: BsInfo	43
6.1.6.2.22	Type: Ipv4AddressRange	44
6.1.6.2.23	Type: Ipv6PrefixRange	44
6.1.6.2.24	Type: InterfaceUpfInfoItem	44
6.1.6.2.25	Type: UriList	44
6.1.6.2.26	Type: N2InterfaceAmfInfo	44
6.1.6.2.27	Type: TaiRange	45
6.1.6.2.28	Type: TacRange	45
6.1.6.3	Simple data types and enumerations	45
6.1.6.3.1	Introduction	45
6.1.6.3.2	Simple data types	45
6.1.6.3.3	Enumeration: NFType	46
6.1.6.3.4	Enumeration: NotificationType	46
6.1.6.3.5	Enumeration: TransportProtocol	46
6.1.6.3.6	Enumeration: NotificationEventType	47
6.1.6.3.7	Enumeration: NFStatus	47
6.1.6.3.8	Enumeration: DataSetId	47
6.1.6.3.9	Enumeration: UPInterfaceType	47
6.1.6.3.10	Relation Types	47
6.1.6.3.10.1	General	47
6.1.6.3.11	Enumeration: ServiceName	48
6.1.6.3.12	Enumeration: NFSERVICEStatus	48
6.1.7	Error Handling	48
6.1.7.1	General	48
6.1.7.2	Protocol Errors	48
6.1.7.3	Application Errors	48
6.1.8	Security	49
6.2	Nnrf_NFDISCOVERY Service API	49
6.2.1	API URI	49
6.2.2	Usage of HTTP	49
6.2.2.1	General	49
6.2.2.2	HTTP Standard Headers	49
6.2.2.2.1	General	49
6.2.2.2.2	Content type	49
6.2.2.2.3	Cache-Control	49
6.2.2.2.4	ETag	50
6.2.2.2.5	If-None-Match	50
6.2.2.3	HTTP custom headers	50
6.2.2.3.1	General	50
6.2.3	Resources	50
6.2.3.1	Overview	50
6.2.3.2	Resource: nf-instances (Store)	50
6.2.3.2.1	Description	50
6.2.3.2.2	Resource Definition	50
6.2.3.2.3	Resource Standard Methods	51
6.2.3.2.3.1	GET	51
6.2.3.2.4	Resource Custom Operations	55
6.2.4	Custom Operations without associated resources	55
6.2.5	Notifications	55
6.2.6	Data Model	55
6.2.6.1	General	55
6.2.6.2	Structured data types	56
6.2.6.2.1	Introduction	56
6.2.6.2.2	Type: SearchResult	56
6.2.6.2.3	Type: NFProfile	57
6.2.6.2.4	Type: NFSERVICE	58
6.2.6.3	Simple data types and enumerations	58

6.2.6.3.1	Introduction	58
6.2.6.3.2	Simple data types.....	58
6.2.7	Error Handling	59
6.2.7.1	General	59
6.2.7.2	Protocol Errors	59
6.2.7.3	Application Errors	59
6.2.8	Security	59
6.3	OAuth2.0 Authorization Service API.....	59
6.3.1	General.....	59
6.3.2	API URI.....	59
6.3.3	Usage of HTTP	59
6.3.3.1	General	59
6.3.3.2	HTTP standard headers	60
6.3.3.2.1	General	60
6.3.3.2.2	Content type	60
6.3.3.3	HTTP custom headers	60
6.3.3.3.1	General	60
6.3.4	Custom Operation without Associated Resources	60
6.3.4.1	Overview	60
6.3.4.2	Operation: Access Token Request	60
6.3.4.2.1	Description	60
6.3.4.2.2	Operation Definition.....	60
6.3.5	Data Model	61
6.3.5.1	General	61
6.3.5.2	Structured data types	61
6.3.5.2.1	Introduction	61
6.3.5.2.2	Type: AccessTokenReq.....	62
6.3.5.2.3	Type: AccessTokenRsp.....	62
6.3.5.2.4	Type: AccessTokenClaims	63
6.3.5.3	Simple data types and enumerations	63
6.3.5.3.1	Introduction	63
6.3.5.3.2	Simple data types.....	63
6.3.5.3.3	Enumeration: GrantType	63
Annex A (normative):	OpenAPI specification.....	64
A.1	General	64
A.2	Nnrf_NFManagement API.....	64
A.3	Nnrf_NFDiscovery API	76
A.4	NRF OAuth2 Authorization	81
Annex B (informative):	Change history	84
History		86

Foreword

This Technical Specification has been produced by the 3rd Generation Partnership Project (3GPP).

The contents of the present document are subject to continuing work within the TSG and may change following formal TSG approval. Should the TSG modify the contents of the present document, it will be re-released by the TSG with an identifying change of release date and an increase in version number as follows:

Version x.y.z

where:

- x the first digit:
 - 1 presented to TSG for information;
 - 2 presented to TSG for approval;
 - 3 or greater indicates TSG approved document under change control.
- y the second digit is incremented for all changes of substance, i.e. technical enhancements, corrections, updates, etc.
- z the third digit is incremented when editorial only changes have been incorporated in the document.

Introduction

This clause is optional. If it exists, it is always the second unnumbered clause.

PREVIEW
iTech STANDARD
(standards.iteh.ai)
Full standard:
<https://standards.iteh.ai/catalog/standards/sist/dfda8c2b-6893-48a9-bc88-3725c6fda506/etsi-ts-129-510-v15.1.0-2018-10>

1 Scope

The present document specifies the stage 3 protocol and data model for the Nnrf Service Based Interface. It provides stage 3 protocol definitions and message flows, and specifies the API for each service offered by the NRF.

The 5G System stage 2 architecture and procedures are specified in 3GPP TS 23.501 [2] and 3GPP TS 23.502 [3].

The Technical Realization of the Service Based Architecture and the Principles and Guidelines for Services Definition are specified in 3GPP TS 29.500 [4] and 3GPP TS 29.501 [5].

2 References

The following documents contain provisions which, through reference in this text, constitute provisions of the present document.

- References are either specific (identified by date of publication, edition number, version number, etc.) or non-specific.
- For a specific reference, subsequent revisions do not apply.
- For a non-specific reference, the latest version applies. In the case of a reference to a 3GPP document (including a GSM document), a non-specific reference implicitly refers to the latest version of that document *in the same Release as the present document*.

- [1] 3GPP TR 21.905: "Vocabulary for 3GPP Specifications".
- [2] 3GPP TS 23.501: "System Architecture for the 5G System; Stage 2".
- [3] 3GPP TS 23.502: "Procedures for the 5G System; Stage 2".
- [4] 3GPP TS 29.500: "5G System; Technical Realization of Service Based Architecture; Stage 3".
- [5] 3GPP TS 29.501: "5G System; Principles and Guidelines for Services Definition; Stage 3".
- [6] 3GPP TS 29.518: "5G System; Access and Mobility Management Services; Stage 3".
- [7] 3GPP TS 29.571: "5G System; Common Data Types for Service Based Interfaces; Stage 3".
- [8] ECMA-262: "ECMAScript® Language Specification", <https://www.ecma-international.org/ecma-262/5.1/>.
- [9] IETF RFC 7540: "Hypertext Transfer Protocol Version 2 (HTTP/2)".
- [10] OpenAPI Initiative, "OpenAPI 3.0.0 Specification", <https://github.com/OAI/OpenAPI-Specification/blob/master/versions/3.0.0.md>.
- [11] IETF RFC 7807: "Problem Details for HTTP APIs".
- [12] 3GPP TS 23.003: "Numbering, Addressing and Identification".
- [13] IETF RFC 6902: "JavaScript Object Notation (JSON) Patch".
- [14] IETF RFC 6901: "JavaScript Object Notation (JSON) Pointer".
- [15] 3GPP TS 33.501: "Security architecture and procedures for 5G system".
- [16] IETF RFC 6749: "The OAuth 2.0 Authorization Framework".
- [17] IETF RFC 3986: "Uniform Resource Identifier (URI): Generic Syntax".
- [18] IETF RFC 4122: "A Universally Unique Identifier (UUID) URN Namespace".
- [19] IETF RFC 7232: "Hypertext Transfer Protocol (HTTP/1.1): Conditional Requests".
- [20] IETF RFC 7234: "Hypertext Transfer Protocol (HTTP/1.1): Caching".

- [21] 3GPP TS 29.244: "Interface between the Control Plane and the User Plane Nodes; Stage 3".
- [22] IETF RFC 8259: "The JavaScript Object Notation (JSON) Data Interchange Format".
- [23] IETF RFC 2782: "A DNS RR for specifying the location of services (DNS SRV)".
- [24] IETF RFC 7515: "JSON Web Signature (JWS)".
- [25] IETF RFC 7519: "JSON Web Token (JWT)".
- [26] W3C HTML 4.01 Specification, <https://www.w3.org/TR/2018/SPSD-html401-20180327/>.
- [27] 3GPP TS 23.527: "5G System; Restoration Procedures; Stage 2".

3 Definitions and abbreviations

3.1 Definitions

For the purposes of the present document, the terms and definitions given in 3GPP TR 21.905 [1] and the following apply. A term defined in the present document takes precedence over the definition of the same term, if any, in 3GPP TR 21.905 [1].

3.2 Abbreviations

For the purposes of the present document, the abbreviations given in 3GPP TR 21.905 [1] and the following apply. An abbreviation defined in the present document takes precedence over the definition of the same abbreviation, if any, in 3GPP TR 21.905 [1].

5GC	5G Core Network
CHF	Charging Function
NF	Network Function
NRF	NF Repository Function

4 Overview

The Network Function (NF) Repository Function (NRF) is the network entity in the 5G Core Network (5GC) supporting the following functionality:

- Maintains the NF profile of available NF instances and their supported services;
- Allows other NF instances to subscribe to, and get notified about, the registration in NRF of new NF instances of a given type;
- Supports service discovery function. It receives NF Discovery Requests from NF instances, and provides the information of the available NF instances fulfilling certain criteria (e.g., supporting a given service).

Figure 4-1 shows the reference architecture for the 5GC, with focus on the NRF:

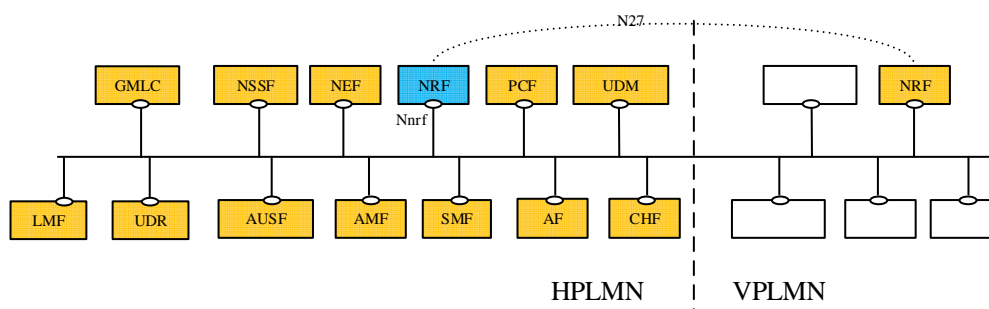

Figure 4-1: 5G System architecture

For the sake of clarity, the NRF is never depicted in reference point representation figures, given that the NRF interacts with every other NF in the 5GC. As an exception, in the roaming case, the reference point between the vNRF and the hNRF is named as N27. The reference point name of N27 is used only for representation purposes, but its functionality is included in the services offered by the Nnrf Service-Based Interface.

5 Services Offered by the NRF

5.1 Introduction

The NRF offers to other NFs the following services:

- Nnrf_NFManagement
- Nnrf_NFDiscovery
- OAuth2 Authorization

5.2 Nnrf_NFManagement Service

5.2.1 Service Description

The Nnrf_NFManagement service allows a Network Function Instance in the serving PLMN to register, update or deregister its profile in the NRF.

It also allows an NF to subscribe to be notified of newly registered NF Instances along with their NF services.

The NF profile consists of general parameters of the NF Instance, and also the parameters of the different services exposed by the NF Instance.

5.2.2 Service Operations

5.2.2.1 Introduction

The services operations defined for the Nnrf_NFManagement service are as follows:

- **NFRegister:** It allows an NF Instance to register its NF profile in the NRF; it includes the registration of the general parameters of the NF Instance, together with the list of services exposed by the NF Instance. This service operation is not allowed to be invoked from an NRF in a different PLMN.
- **NFUpdate:** It allows an NF Instance to replace, or update partially, the parameters of its NF profile (including the parameters of the associated services) in the NRF; it also allows to add or delete individual services offered by the NF Instance. This service operation is not allowed to be invoked from an NRF in a different PLMN.
- **NFDeregister:** It allows an NF Instance to deregister its NF profile in the NRF, including the services offered by the NF Instance. This service operation is not allowed to be invoked from an NRF in a different PLMN.
- **NFStatusSubscribe:** It allows an NF Instance to subscribe to changes on the status of NF Instances registered in NRF. This service operation can be invoked by an NF Instance in a different PLMN (via the local NRF in that PLMN).
- **NFStatusNotify:** It allows the NRF to notify subscribed NF Instances of changes on the status of NF Instances. This service operation can be invoked directly between the NRF and an NF Instance in a different PLMN (without involvement of the local NRF in that PLMN).
- **NFStatusUnsubscribe:** It allows an NF Instance to unsubscribe to changes on the status of NF Instances registered in NRF. This service operation can be invoked by an NF Instance in a different PLMN (via the local NRF in that PLMN).

NOTE: The "change of status" of the NFStatus service operations can imply a request to be notified of newly registered NF Instances in NRF, or to be notified of profile changes of a specific NF Instance, or to be notified of the deregistration of an NF Instance.

The NFStatusSubscribe / NFStatusNotify / NFStatusUnsubscribe operations can be invoked by an NF Service Consumer (i.e., "source NF") requesting to be notified about events (registration, deregistration, profile change) related to an NF instance (i.e., "target NF") located in the same PLMN, or in a different PLMN.

In the description of these operations in subclauses 5.2.2.5, 5.2.2.6 and 5.2.2.7, when the NF instances are located in the same PLMN, both source NF and target NF are said to be located in the "Serving PLMN" but, in the general case, the functionality is not restricted to the PLMN that is serving a given UE, and it shall be applicable as well to any scenario in which source NF and target NFs belong to the same PLMN.

When source NF and target NF are located in different PLMNs, the source NF is said to be in the "Serving PLMN", and the target NF (and the NRF where such NF is registered) is said to be in the "Home PLMN", similarly to the scenarios described in 3GPP TS 23.502 [2], but the functionality shall be equally applicable to any scenario between any pair of PLMNs (e.g. with the source NF in the Home PLMN and the target NF in the Serving PLMN).

5.2.2.2 NFRegister

5.2.2.2.1 General

This service operation is used:

- to register an NF in the NRF by providing the NF profile of the requesting NF to the NRF, and the NRF marks the requesting NF as available to be discovered by other NFs;
- to register services associated to an existing NF Instance;
- to register NRF information in another NRF, and this information is used for forwarding or redirecting service discovery request.

5.2.2.2.2 NF (other than NRF) registration to NRF

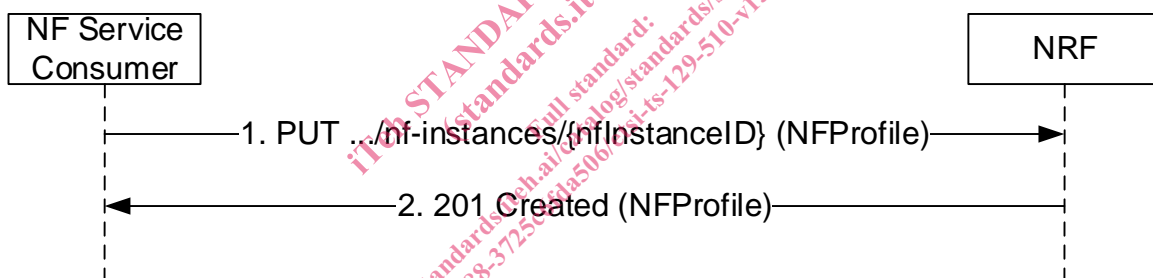

Figure 5.2.2.2.1-1: NF Instance Registration

1. The NF Service Consumer shall send a PUT request to the resource URI representing the NF Instance. The URI is determined by the NF Instance. The variable {nfInstanceID} represents an identifier, provided by the NF Service Consumer, that shall be globally unique inside the PLMN of the NRF where the NF is being registered. The format of the NF Instance ID shall be a Universally Unique Identifier (UUID) version 4, as described in IETF RFC 4122 [18].

EXAMPLE: UUID version 4: "4947a69a-f61b-4bc1-b9da-47c9c5d14b64"

The payload body of the PUT request shall contain a representation of the NF Instance to be created.

2. On success, "201 Created" shall be returned, the payload body of the PUT response shall contain the representation of the created resource and the "Location" header shall contain the URI of the created resource. Additionally, the NRF returns a "heart-beat timer" containing the number of seconds expected between two consecutive heart-beat messages from an NF Instance to the NRF (see subclause 5.2.2.3.2).

If the registration of the NF instance fails at the NRF due to errors in the encoding of the NFProfile JSON object, the NRF shall return "400 Bad Request" status code with the ProblemDetails IE providing details of the error.

If the registration of the NF instance fails at the NRF due to NRF internal errors, the NRF shall return "500 Internal Server Error" status code with the ProblemDetails IE providing details of the error.

The NRF shall allow the registration of a Network Function instance with any of the NF types described in subclause 6.1.6.3.3, and it shall also allow registration of Network Function instances with custom NF types (e.g., NF type values not defined by 3GPP, or NF type values not defined by this API version).

NOTE: When registering a custom NF in NRF, it is recommended to use a NF type name that prevents collisions with other custom NF type names, or with NF types defined in the future by 3GPP. E.g., prefixing the custom NF type name with the string "CUSTOM_".

During the registration of a Network Function instance with a custom NF type, the NF instance may provide NF-specific data (in the "customInfo" attribute), that shall be stored by the NRF as part of the NF profile of the NF instance.

5.2.2.2.3 NRF registration to another NRF

The procedure specified in subclause 5.2.2.2.2 applies. Additionally:

- a) the registering NRF shall set the nfType to "NRF" in the nfProfile;
- b) the registering NRF shall set the nfService to contain "nrf-disc" and "nrf-nfm" in the nfProfile;
- c) the registering NRF may include udrInfo, udmInfo, ausfInfo, amfInfo, smfInfo, upfInfo, pcfnInfo and bsfnInfo in the nfProfile, this means the registering NRF is able to provide service for discovery of NFs subject to that information;
- d) if the NRF receives an NF registration with the nfType set to "NRF", the NRF shall use the information contained in the nfProfile to target the registering NRF when forwarding or redirecting NF service discovery request.

Editor's Note: The details of the nfProfile used for NRF registration to another NRF is FFS.

5.2.2.3 NFUpdate

5.2.2.3.1 General

This service operation updates the profile of a Network Function previously registered in the NRF by providing the updated NF profile of the requesting NF to the NRF. The update operation may apply to the whole profile of the NF (complete replacement of the existing profile by a new profile), or it may apply only to a subset of the parameters of the profile (including adding/deleting/replacing services to the NF profile).

To perform a complete replacement of the NF Profile of a given NF Instance, the NF Service Consumer shall issue an HTTP PUT request, as shown in Figure 5.2.2.3.1-1:

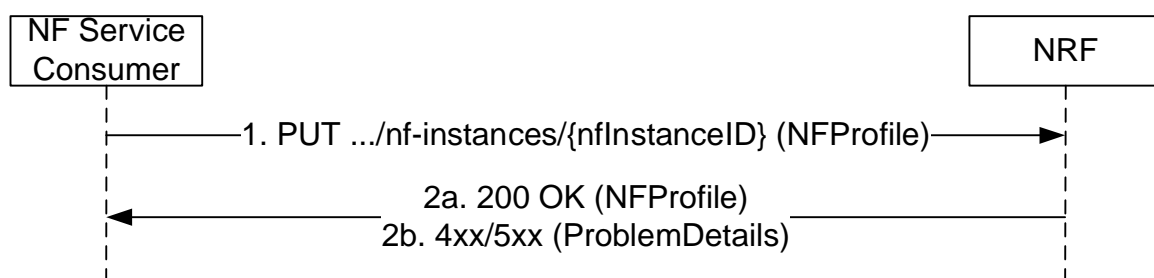

Figure 5.2.2.3.1-1: NF Profile Complete Replacement

1. The NF Service Consumer shall send a PUT request to the resource URI representing the NF Instance. The payload body of the PUT request shall contain a representation of the NF Instance to be completely replaced in the NRF.
- 2a. On success, "200 OK" shall be returned, the payload body of the PUT response shall contain the representation of the replaced resource.
- 2b. If the update of the NF instance fails at the NRF due to errors in the encoding of the NFProfile JSON object, the NRF shall return "400 Bad Request" status code with the ProblemDetails IE providing details of the error.