



Designation: D197 – 87 (Reapproved2007)

Standard Test Method for Sampling and Fineness Test of Pulverized Coal¹

This standard is issued under the fixed designation D197; the number immediately following the designation indicates the year of original adoption or, in the case of revision, the year of last revision. A number in parentheses indicates the year of last reapproval. A superscript epsilon (ϵ) indicates an editorial change since the last revision or reapproval.

1. Scope

1.1 This test method covers the determination of the fineness by sieve analysis of coal sampled from a dry pulverizing operation. It is not applicable to products of wet milling or to fines that have clustered into an agglomerated mass.

1.2 The values stated in inch-pound units shall be regarded as the standard. Sample weights of 1000 g or less shall be expressed in metric units.

1.3 *This standard does not purport to address all of the safety concerns, if any, associated with its use. It is the responsibility of the user of this standard to establish appropriate safety and health practices and determine the applicability of regulatory limitations prior to use.*

2. Referenced Documents

2.1 *ASTM Standards:*²

E11 Specification for Woven Wire Test Sieve Cloth and Test Sieves

3. Significance and Use

3.1 This test method provides a means for assisting in the evaluation of pulverizers and pulverizer systems in terms of fineness specifications. It may also be used to confirm the influence of coal fineness on combustion performance and to evaluate carbon loss. By consent among interested parties, it may be used for evaluation of coal fineness in preparation, pneumatic transfer systems, etc.

4. Apparatus

4.1 *Sample Containers*—Heavy vapor impervious bags, properly sealed, or noncorroding cans such as those with an airtight, friction top or screw top sealed with a rubber gasket and pressure sensitive tape for use in storage and transport of

the laboratory sample. Glass containers sealed with rubber gaskets may be used, but care must be taken to avoid breakage in transport.

4.2 *Drying Oven*—A device for passing slightly heated air over the sample. The oven should be capable of maintaining a temperature of 18 to 27°F (10 to 15°C) above room temperature with a maximum oven temperature of 104°F (40°C). Air changes should be at the rate of 1 to 4/min.

4.3 *Sieves*, square-hole, woven-wire cloth conforming to Specification E11:

- No. 8 USA Standard (2.36 mm)
- No. 16 USA Standard (1.18 mm)
- No. 30 USA Standard (600 μ m)
- No. 50 USA Standard (300 μ m)
- No. 100 USA Standard (150 μ m)
- No. 200 USA Standard (75 μ m)
- No. 325 USA Standard (45 μ m)

The sieve frames shall be 8 in. (203 mm) in diameter, and the height of the sieve from the top of the frame to the cloth shall be either 2 in. (50.8 mm) or 1 in. (25.4 mm). Selection of specific sizes is optional, depending on the objective of the test.

4.3.1 Since the finer mesh sieves in particular are susceptible to damage by distortion resulting from undue pressure, accidental scraping with hard brushes, etc., each sieve should be closely inspected and discarded if it shows evidence of damage.

4.4 *Mechanical Sieving Machine*—The mechanical sieving machine shall be designed to provide both a circular motion and a tapping action. It shall be designed to accept an assembly of vertically nested circular sieves as described in 4.3. The machine action shall be such that results as described in Section 7 are obtained within the allotted time frame. Action shall not be sufficiently severe to generate new fines by particle degradation. To facilitate the sieving operation, a control switch device with timer is recommended. Other equipment designs may be used provided the results are comparable.

4.5 *Balance, Laboratory*—Approximately 1000-g capacity, sensitivity 0.1 g.

4.6 *Sampling Device (Storage System)*—An instrument (scoop, dipper, or other suitable device) for collecting increments that will constitute the total sample.

4.7 *Sampling Device (Direct-Fired System)*—Apparatus as described in 6.2.1 and 6.2.2.

¹ This test method is under the jurisdiction of ASTM Committee D05 on Coal and Coke and is the direct responsibility of Subcommittee D05.07 on Physical Characteristics of Coal.

Current edition approved Oct. 1, 2007. Published October 2007. Originally published in 1924. Last previous edition approved in 2002 as D197 – 87 (2002). DOI: 10.1520/D0197-87R07.

² For referenced ASTM standards, visit the ASTM website, www.astm.org, or contact ASTM Customer Service at service@astm.org. For *Annual Book of ASTM Standards* volume information, refer to the standard's Document Summary page on the ASTM website.

4.8 *Sample Riffle with Pans*—A manual sample divider that splits the coal stream into a number of alternate elements. Riffle divisions should be in the size range from ¼ to ½ in. (6.4 to 12.7 mm).

5. Sampling, Storage System

5.1 In the pulverized coal storage system, the coal after pulverization is conveyed into bins.

5.1.1 *Collection of Gross Sample*—Collect not less than ten increments of representative pulverized coal preferably as it is being discharged from the collector. This is best accomplished by collecting increments of not less than 50 g at regular intervals by means of a scoop, dipper, or a device capable of removing an increment from a specific location within the stream of pulverized coal. Place the increments in the sample container and seal.

5.1.2 *Preparation of the Laboratory Sample*—A small riffle (Fig. 1) can be used for mixing and dividing the sample by splitting. An enclosed riffle is preferred. Mix the gross sample by splitting and recombining the halves a minimum of two times. Divide the sample amount by successive riffle splitting operations on one half of the sample until the sample is divided to approximately 500 g for the laboratory sample. To correctly use the riffle, the sample must be poured over the side of a pan (a third pan is necessary) and not from an end or corner, nor from a container such as, a pail or jar. Transfer the sample to a sample container and seal.

5.1.3 As an alternative to riffle mixing and splitting, the sample can be prepared as follows: Place the gross sample on a sheet of rubber, plastic, or paper and mix it by raising first one corner of the cloth and then the other so as to roll the coal over and over at least 20 times. After mixing, divide the sample. Continue the operations of mixing and dividing until the sample is divided sufficiently so that all of one of the divisions weighs approximately 500 g. This shall constitute the laboratory sample.

6. Sampling, Direct-Fired System

6.1 In the direct-fired system, the coal is pulverized and delivered directly to the furnace in an air stream. It is difficult

to obtain representative samples, as it is necessary to sample the coal from a moving stream of coal-air mixture inside the pipe between the pulverizer and furnace. It is preferable to collect such samples from vertical pipes, as in horizontal pipes a greater amount of segregation may take place.

6.2 *Apparatus for Sample Collection*—Because it is difficult to collect a representative sample of solids from a moving coal-air stream, it is essential that the equipment and sampling procedures are uniformly consistent to assure valid and reproducible results. Recommended equipment and sampling arrangements are shown in Fig. 2 and Fig. 3. Except in circumstances where stationary interferences in the area around the sampling location prohibits the use of the sampling equipment as shown in Fig. 3, changes to the equipment should not be allowed. Changes may produce inconsistent results.

6.2.1 Fig. 2 shows the recommended arrangement for sampling pulverized coal in a direct-fired system using a dustless sampling connection with an aspirator and a cyclone collector. In collecting the sample, turn on the compressed air to the dustless connection and adjust to give a balanced pressure at the connection. Insert the sampling tip into the dustless connection with the tip facing directly into the coal-air stream. Readjust the compressed air to give a balanced pressure with the nozzle inserted. Traverse the fuel transport line across the entire diameter of the pipe by moving at a uniform rate with the tip facing directly into the coal-air stream. The aspirating air on the cyclone collector may or may not be used, depending on the static pressure in the fuel transport line, as discussed in 6.3.7.

6.2.2 Fig. 3 shows detailed dimensions of a recommended sampling tip. The area of the tip shown is 0.5 by 0.95 in. or 0.475 in.² (12.7 by 24.1 mm or 306 mm²), which is the projected area of the tip facing the coal-air stream. Other tip configurations and dimensions can be employed provided they permit the collection of an unbiased sample from the coal stream. See Appendix X1.

6.3 Collection of Gross Sample:

6.3.1 In sampling, it is essential that the velocity into the sampling tip be nearly the same as the velocity in the pipe. If the velocity in the sampling tube is insufficient, the full quota of the coarse particles will be entrained, but some of the fine particles that should be caught will follow the air in passing around the tip. If the velocity in the sampling tube is greater, more than the proper number of fine particles will be drawn into the sampling tip.

6.3.2 A procedure for confirming sample validity is included in Appendix X4.

6.3.3 A sample obtained in a given time should be weighed and compared with the weight of coal passing through the fuel transport line. The weight of the coal passing through the pipe may be determined from the total coal to the pulverizer divided by number of pipes. The weight of coal passing through the fuel transport line, multiplied by the ratio of the cross-sectional area of the sampling tip to that of the pipe, should be approximately equal to the sample weight (see 6.3.9). For example, if a pulverizer has an output of 63 000 lb of coal per hour passing through six lines, and if each line is 15.25 in. (387 mm) in inside diameter, with a cross-sectional area of 182.65

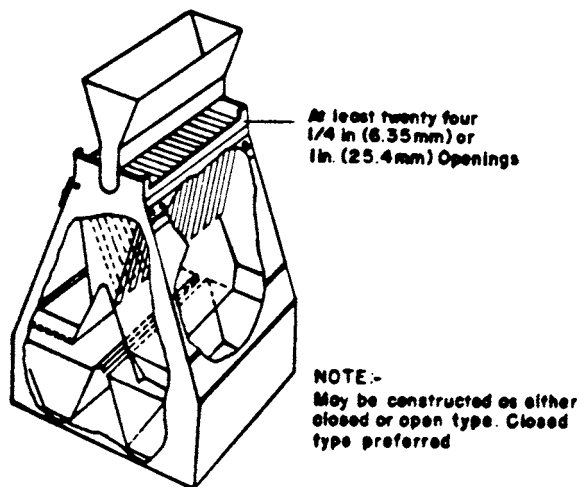

FIG. 1 Sample Divider (Riffle)

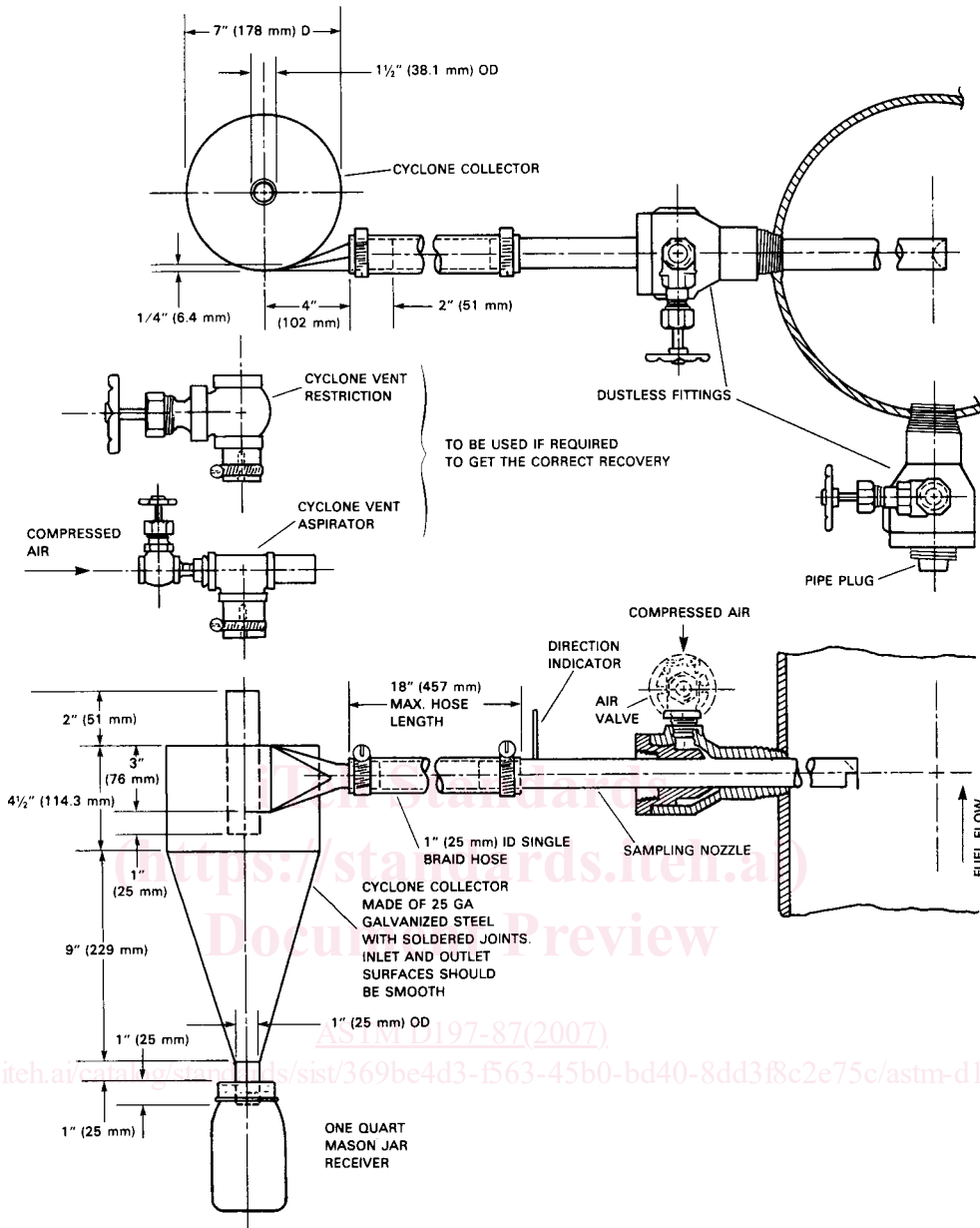

FIG. 2 Recommended Arrangement for Sampling Pulverized Coal in a Direct-Fired System

in.² (1170 cm²) and if the standard sampler has a tip opening of 0.5 by 0.95 in. (12.7 mm by 24.1 mm) and a cross-sectional area of 0.475 in.² (306 mm²), the sample rate per minute with 100 % recovery should then be as follows:

$$\text{Sample rate, lb/min} = 63\,000 \text{ lb/h-pulverizer} \times 1 \text{ h/60 min} \times 1 \text{ pulverizer/6 lines} \times 0.475 \text{ in.}^2/\text{sampler}/182.65 \text{ in.}^2/\text{line} \times 1 \text{ sampler/1 line} = 0.455 \text{ lb/min-line} \text{ (206 g/min-line)}$$

Sampling for a 3-min period should then be 1.37 lb (618 g) for 100 % recovery.

6.3.4 If the recovery is between 90 and 110 %, the sample shall be considered satisfactory as to collection rate for the pipe and flow velocities. See **Appendix X2**.

6.3.5 After taking one or two samples and weighing them for confirmation, the collector vent control can be adjusted to

give a recovery within the 90 and 110 % limits. Discard those samples that do not meet the recovery limits.

6.3.6 If the static pressure in the fuel transport line is so high that the recovery is above 110 % with all aspirator air shut off, throttle the flow from the cyclone to reduce the recovery to the desired range between 90 and 110 %. This can be done by installing a valve or orifice at the cyclone collector vent discharge (see **Fig. 2**).

6.3.7 Samples shall be taken by carefully traversing at least two complete diameters 90° apart. Two common sampling methods are the continuous transversing technique or the equal area method. If preliminary samples taken at each individual line show wide variations in fineness and recovery, better