



Designation: D1556 – 07

Standard Test Method for Density and Unit Weight of Soil in Place by Sand-Cone Method¹

This standard is issued under the fixed designation D1556; the number immediately following the designation indicates the year of original adoption or, in the case of revision, the year of last revision. A number in parentheses indicates the year of last reapproval. A superscript epsilon (ϵ) indicates an editorial change since the last revision or reapproval.

This standard has been approved for use by agencies of the U.S. Department of Defense.

1. Scope*

1.1 This test method may be used to determine the in-place density and unit weight of soils using a sand cone apparatus.

1.2 This test method is applicable for soils without appreciable amounts of rock or coarse materials in excess of 1½ in. (38 mm) in diameter.

1.3 This test method may also be used for the determination of the in-place density and unit weight of intact or *in situ* soils, provided the natural void or pore openings in the soil are small enough to prevent the sand used in the test from entering the voids. The soil or other material being tested should have sufficient cohesion or particle attraction to maintain stable sides on a small hole or excavation, and be firm enough to withstand the minor pressures exerted in digging the hole and placing the apparatus over it, without deforming or sloughing.

1.4 This test method is not suitable for organic, saturated, or highly plastic soils that would deform or compress during the excavation of the test hole. This test method may not be suitable for soils consisting of unbound granular materials that will not maintain stable sides in the test hole, soils containing appreciable amounts of coarse material larger than 1½ in. (38 mm), and granular soils having high void ratios.

1.5 When materials to be tested contain appreciable amounts of particles larger than 1½ in. (38 mm), or when test hole volumes larger than 0.1 ft³ (2830 cm³) are required, Test Method [D4914](#) or [D5030](#) are applicable.

1.6 It is common practice in the engineering profession to concurrently use pounds to represent both a unit of mass (lbm) and a unit of force (lbf). This implicitly combines two separate systems of units, that is, the absolute system and the gravitational system. It is scientifically undesirable to combine the use of two separate sets of inch-pound units within a single standard. This test method has been written using the gravita-

tional system of units when dealing with the inch-pound system. In this system the pound (lbf) represents a unit of force (weight). However, the use of balances or scales recording pounds of mass (lbm), or the recording of density in lbm/ft³ should not be regarded as nonconformance with this test method.

1.7 All observed and calculated values shall conform to the guidelines for significant digits and rounding established in Practice [D6026](#) unless superseded by this standard.

1.7.1 The procedures used to specify how data are collected, recorded or calculated in this standard are regarded as the industry standard. In addition they are representative of the significant digits that generally should be retained. The procedures used do not consider material variation, purpose for obtaining the data, special purpose studies, or any considerations for the user's objectives; it is common practice to increase or reduce significant digits or reported data to be commensurate with these considerations. It is beyond the scope of this standard to consider significant digits used in analytical methods for engineering design.

1.8 *This standard does not purport to address all of the safety concerns, if any, associated with its use. It is the responsibility of the user of this standard to establish appropriate safety and health practices and determine the applicability of regulatory limitations prior to use.*

2. Referenced Documents

2.1 *ASTM Standards:*²

[D653 Terminology Relating to Soil, Rock, and Contained Fluids](#)

[D698 Test Methods for Laboratory Compaction Characteristics of Soil Using Standard Effort \(12 400 ft-lbf/ft³ \(600 kN-m/m³\)\)](#)

[D1557 Test Methods for Laboratory Compaction Characteristics of Soil Using Modified Effort \(56,000 ft-lbf/ft³ \(2,700 kN-m/m³\)\)](#)

¹ This test method is under the jurisdiction of ASTM Committee [D18](#) on Soil and Rock and is the direct responsibility of Subcommittee [D18.08](#) on Special and Construction Control Tests.

Current edition approved Sept. 15, 2007. Published October 2007. Originally approved in 1958. Last previous edition approved in 2000 as D1556 – 00. DOI: 10.1520/D1556-07.

² For referenced ASTM standards, visit the ASTM website, www.astm.org, or contact ASTM Customer Service at service@astm.org. For *Annual Book of ASTM Standards* volume information, refer to the standard's Document Summary page on the ASTM website.

*A Summary of Changes section appears at the end of this standard

- [D2216 Test Methods for Laboratory Determination of Water \(Moisture\) Content of Soil and Rock by Mass](#)
- [D3740 Practice for Minimum Requirements for Agencies Engaged in Testing and/or Inspection of Soil and Rock as Used in Engineering Design and Construction](#)
- [D4253 Test Methods for Maximum Index Density and Unit Weight of Soils Using a Vibratory Table](#)
- [D4254 Test Methods for Minimum Index Density and Unit Weight of Soils and Calculation of Relative Density](#)
- [D4643 Test Method for Determination of Water \(Moisture\) Content of Soil by Microwave Oven Heating](#)
- [D4718 Practice for Correction of Unit Weight and Water Content for Soils Containing Oversize Particles](#)
- [D4753 Guide for Evaluating, Selecting, and Specifying Balances and Standard Masses for Use in Soil, Rock, and Construction Materials Testing](#)
- [D4914 Test Methods for Density and Unit Weight of Soil and Rock in Place by the Sand Replacement Method in a Test Pit](#)
- [D4944 Test Method for Field Determination of Water \(Moisture\) Content of Soil by the Calcium Carbide Gas Pressure Tester](#)
- [D4959 Test Method for Determination of Water \(Moisture\) Content of Soil By Direct Heating](#)
- [D5030 Test Method for Density of Soil and Rock in Place by the Water Replacement Method in a Test Pit](#)
- [D6026 Practice for Using Significant Digits in Geotechnical Data](#)

mass measurements to the nearest 5 g. As such water content calculations should only be reported to two significant digits and density to three significant digits.

5.2 This test method can be used to determine the in-place density of natural soil deposits, aggregates, soil mixtures, or other similar material.

5.3 The use of this test method is generally limited to soil in an unsaturated condition. This test method is not recommended for soils that are soft or friable (crumble easily) or in a moisture condition such that water seeps into the hand excavated hole. The precision of the test may be affected for soils that deform easily or that may undergo a volume change in the excavated hole from vibration, or from standing or walking near the hole during the test (see [Note 1](#)).

NOTE 1—When testing in soft conditions or in soils near saturation, volume changes may occur in the excavated hole as a result of surface loading, personnel performing the test, and the like. This can sometimes be avoided by the use of a platform that is supported some distance from the hole. As it is not always possible to detect when a volume change has taken place, test results should always be compared to the theoretical saturation density, or the zero air voids line on the dry density versus water content plot. Any in-place density test on compacted soils that calculates to be more than 95 % saturation is suspect and an error has probably occurred, or the volume of the hole has changed during testing.

NOTE 2—Notwithstanding the statements on precision and bias contained in this test method, the precision of this test method is dependent on the competence of the personnel performing it, and the suitability of the equipment and facilities used. Agencies that meet the criteria of Practice [D3740](#) are generally considered capable of competent and objective testing. Users of this test method are cautioned that compliance with Practice [D3740](#) does not in itself ensure reliable testing. Reliable testing depends on many factors; Practice [D3740](#) provides a means of evaluating some of those factors.

3. Terminology

3.1 *Definitions*—For definitions of terms in this standard, refer to Terminology [D653](#).

3.2 *Definitions of Terms Specific to This Standard:*

3.2.1 *compacted lift, n*—a layer of compacted soil.

4. Summary of Test Method

4.1 A test hole is hand excavated in the soil to be tested and all the material from the hole is saved in a container. The hole is filled with free flowing sand of a known density, and the volume is determined. The in-place wet density of the soil is determined by dividing the wet mass of the removed material by the volume of the hole. The water content of the material from the hole is determined and the dry mass of the material and the in-place dry density are calculated using the wet mass of the soil, the water content, and the volume of the hole.

5. Significance and Use

5.1 This test method is used to determine the density and water content of compacted soils placed during the construction of earth embankments, road fill, and structural backfill. It often is used as a basis of acceptance for soils compacted to a specified density or percentage of a maximum density determined by a test method, such as Test Methods [D698](#) or [D1557](#).

5.1.1 Test Methods [D698](#) and [D1557](#) require that mass measurements of laboratory compacted test specimens be determined to the nearest 1 g so that computed water contents and densities can be reported to three and four significant digits, respectively. This standard is a field procedure requiring

6. Apparatus

6.1 *Sand-Cone Density Apparatus*, consisting of sand container, sand cone, and base plate.

6.1.1 *Sand Container*, an attachable jar or other sand container having a volume capacity in excess of that required to fill the test hole and sand cone during the test.

6.1.2 *Sand Cone*, a detachable appliance consisting of a cylindrical valve with an orifice approximately ½ in. (13 mm) in diameter, attached to a metal funnel and sand container on one end, and a large metal funnel (sand-cone) on the other end. The valve will have stops to prevent rotating past the completely open or completely closed positions. The appliance will be constructed of metal sufficiently rigid to prevent distortion or volume changes in the cone. The walls of the cone will form an angle of approximately 60° with the base to allow uniform filling with sand.

6.1.3 *Base Plate*, a metal base plate or template with a flanged center hole cast or machined to receive the large funnel (cone) of the appliance described in [6.1.2](#). The base plate may be round or square and will be a minimum of 3 in. (75 mm) larger than the funnel (sand-cone). The plate will be flat on the bottom and have sufficient thickness or stiffness to be rigid. Plates with raised edges, ridges, ribs, or other stiffeners of approximately ¾ to ½ in. (10 to 13 mm) high may be used.

6.1.4 The mass of the sand required to fill the sand cone and base plate will be determined in accordance with the instructions in [Annex A1](#) prior to use.

6.1.5 The details for the apparatus shown in Fig. 1 represents the minimum acceptable dimensions suitable for testing soils having maximum particle sizes of approximately 1½ in. (38 mm) and test hole volumes of approximately 0.1 ft³ (2830 cm³). When the material being tested contains a small amount of oversize and isolated larger particles are encountered, the test should be moved to a new location. Larger apparatus and test hole volumes are needed when particles larger than 1½ in. (38 mm) are prevalent. The apparatus described here represents a design that has proven satisfactory. Larger apparatus, or other designs of similar proportions may be used as long as the basic principles of the sand volume determination are observed. When test hole volumes larger than 0.1 ft³ (5660 cm³) are required Test Method D4914 should be utilized.

6.2 Sand—Sand must be clean, dry, uniform in density and grading, uncemented, durable, and free-flowing. Any gradation may be used that has a uniformity coefficient ($C_u = D_{60}/D_{10}$) less than 2.0, a maximum particle size smaller than 2.0 mm (No. 10 sieve), and less than 3 % by weight passing 250 µm (No. 60 sieve). Uniformly graded sand is needed to prevent segregation during handling, storage, and use. Sand free of fines and fine sand particles is required to prevent significant bulk-density changes with normal daily changes in atmospheric humidity. Sand comprised of durable, natural

subrounded, or rounded particles is desirable. Crushed sand or sand having angular particles may not be free-flowing, a condition that can cause bridging resulting in inaccurate density determinations (see Note 3). In selecting a sand from a potential source, a gradation and bulk-density determinations in accordance with the procedure in Annex A2 should be made on each container or bag of sand. To be an acceptable sand, the bulk-density variation between any one determination shall not be greater than 1 % of the average. Before using sand in density determinations, it shall be dried, then allowed to reach an air-dried state in the general location where it is to be used (see Note 4). Sand shall not be re-used without removing any contaminating soil, checking the gradation, drying and re-determining the bulk-density (see Note 5). Bulk-density tests of the sand will be made at time intervals not exceeding 14 days, always after any significant changes in atmospheric humidity, before reusing, and before use of a new batch from a previously approved supplier (see Note 6).

NOTE 3—Some manufactured (crushed) sands such as blasting sand have been successfully used with good reproducibility. The reproducibility of test results using angular sand should be checked under laboratory controlled testing situations before selecting an angular sand for use.

NOTE 4—Many organizations have found it beneficial to store sands in moisture resistant containers. Sand should be stored in dry areas protected from weather. The use of a lighted bulb or other heat source in, or adjacent to the storage containers has also been found to be beneficial in areas of high humidity.

NOTE 5—As a general rule, reclaiming sand after testing is not desirable.

NOTE 6—Most sands have a tendency to absorb moisture from the atmosphere. A very small amount of absorbed moisture can make a substantial change in bulk-density. In areas of high humidity, or where the humidity changes frequently, the bulk-density may need to be determined more often than the 14 day maximum interval indicated. The need for more frequent checks can be determined by comparing the results of different bulk-density tests on the same sand made in the same conditions of use over a period of time.

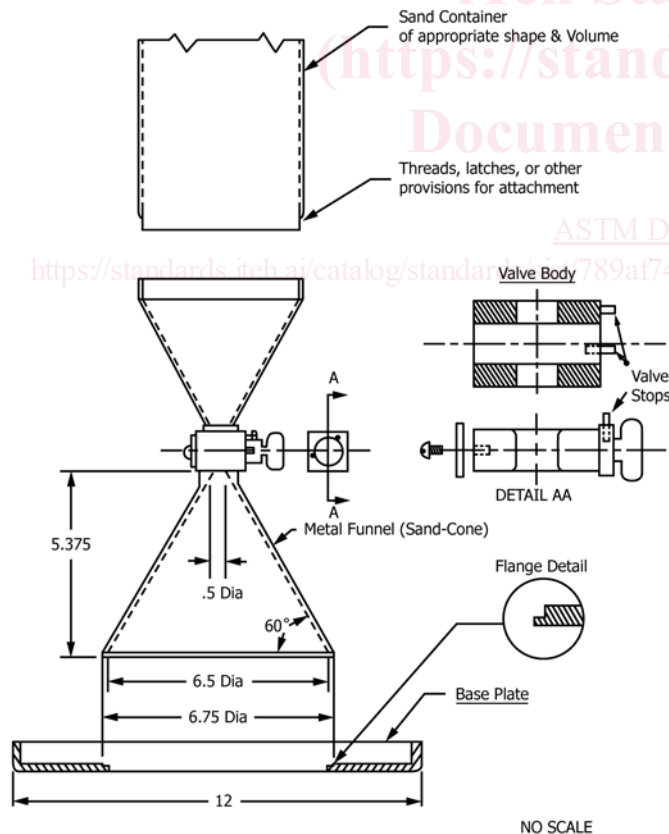

Metric Equivalents	
in.	mm
.5	12.7
5.375	136.5
6.5	165.1
6.75	171.5
12	304.8

FIG. 1 Density Apparatus

6.3 Balances or Scales—Meeting Specification D4753, with 5.0 g readability, or better, to determine the mass of sand and excavated soils. A balance or scale having a minimum capacity of 20 kg (44 lbf) and 5 g (0.01 lbf) readability is suitable for determining the mass of the sand and the excavated soil when apparatus with the dimensions shown in Fig. 1 is used.

6.4 Drying Equipment—Equipment corresponding to the method used for determining water content as specified in Test Methods D2216, D4643, D4959, or D4944.

6.5 Miscellaneous Equipment—Knife, small pick, chisel, small trowel, screwdriver, or spoons for digging test holes, large nails or spikes for securing the base plate; buckets with lids, plastic-lined cloth sacks, or other suitable containers for retaining the density samples, moisture sample, and density sand respectively; small paint brush, calculator, notebook or test forms, etc.

7. Procedure

7.1 Select a location/elevation that is representative of the area to be tested, and determine the density of the soil in-place as follows:

7.1.1 Inspect the cone apparatus for damage, free rotation of the valve, and properly matched baseplate. Fill the cone