

# DRAFT AMENDMENT ISO 28927-8:2009/DAM 1

ISO/TC 118/SC 3

Secretariat: SIS

Voting begins on:  
2013-11-28

Voting terminates on:  
2014-04-28

---

---

## Hand-held portable power tools — Test methods for evaluation of vibration emission —

Part 8:

### Saws, polishing and filing machines with reciprocating action and small saws with oscillating or rotating action

#### AMENDMENT 1

*Machines à moteur portatives — Méthodes d'essai pour l'évaluation de l'émission de vibrations —  
Partie 8: Scies, polisseuses et limes alternatives, et petites scies oscillantes ou circulaires*  
AMENDEMENT 1

ICS: 13.160;25.140.10

**ITeH STANDARD PREVIEW**  
(standards.iteh.ai)  
Full standard:  
<https://standards.iteh.ai/catalog/standards/sis/e996b688-eeeb-4d9b-8a42-071971535174/iso-28927-8:2009/amd-1-2015>

#### ISO/CEN PARALLEL PROCESSING

This draft has been developed within the International Organization for Standardization (ISO), and processed under the **ISO lead** mode of collaboration as defined in the Vienna Agreement.

This draft is hereby submitted to the ISO member bodies and to the CEN member bodies for a parallel five month enquiry.

Should this draft be accepted, a final draft, established on the basis of comments received, will be submitted to a parallel two-month approval vote in ISO and formal vote in CEN.

To expedite distribution, this document is circulated as received from the committee secretariat. ISO Central Secretariat work of editing and text composition will be undertaken at publication stage.

THIS DOCUMENT IS A DRAFT CIRCULATED FOR COMMENT AND APPROVAL. IT IS THEREFORE SUBJECT TO CHANGE AND MAY NOT BE REFERRED TO AS AN INTERNATIONAL STANDARD UNTIL PUBLISHED AS SUCH.

IN ADDITION TO THEIR EVALUATION AS BEING ACCEPTABLE FOR INDUSTRIAL, TECHNOLOGICAL, COMMERCIAL AND USER PURPOSES, DRAFT INTERNATIONAL STANDARDS MAY ON OCCASION HAVE TO BE CONSIDERED IN THE LIGHT OF THEIR POTENTIAL TO BECOME STANDARDS TO WHICH REFERENCE MAY BE MADE IN NATIONAL REGULATIONS.

RECIPIENTS OF THIS DRAFT ARE INVITED TO SUBMIT, WITH THEIR COMMENTS, NOTIFICATION OF ANY RELEVANT PATENT RIGHTS OF WHICH THEY ARE AWARE AND TO PROVIDE SUPPORTING DOCUMENTATION.



Reference number  
ISO 28927-8:2009(E)/DAM 1

© ISO 2013

**iTeh STANDARD PREVIEW**  
(standards.iteh.ai)  
Full standard:  
<https://standards.iteh.ai/catalog/standards/sist/e996b688-eeeb-4d9b-8a42-071971535174/iso-28927-8-2009-amd-1-2015>

### Copyright notice

This ISO document is a Draft International Standard and is copyright-protected by ISO. Except as permitted under the applicable laws of the user's country, neither this ISO draft nor any extract from it may be reproduced, stored in a retrieval system or transmitted in any form or by any means, electronic, photocopying, recording or otherwise, without prior written permission being secured.

Requests for permission to reproduce should be addressed to either ISO at the address below or ISO's member body in the country of the requester.

ISO copyright office  
Case postale 56 • CH-1211 Geneva 20  
Tel. + 41 22 749 01 11  
Fax + 41 22 749 09 47  
E-mail [copyright@iso.org](mailto:copyright@iso.org)  
Web [www.iso.org](http://www.iso.org)

Reproduction may be subject to royalty payments or a licensing agreement.

Violators may be prosecuted.

# Contents

Page

Foreword .....	iv
Introduction.....	vi
1 Scope .....	1
2 Normative references .....	1
3 Terms, definitions and symbols .....	2
3.1 Terms and definitions .....	2
3.2 Symbols.....	2
4 Basic standards and vibration test codes .....	3
5 Description of the family of machines .....	3
6 Characterization of vibration.....	8
6.1 Direction of measurement .....	8
6.2 Location of measurements.....	8
6.3 Magnitude of vibration .....	16
6.4 Combination of vibration directions.....	16
7 Instrumentation requirements.....	16
7.1 General .....	16
7.2 Mounting of transducers .....	16
7.2.1 Specification of transducer .....	16
7.2.2 Fastening of transducers.....	16
7.3 Frequency weighting filter.....	16
7.4 Integration time.....	16
7.5 Auxiliary equipment .....	17
7.6 Calibration .....	17
8 Testing and operating conditions of the machinery.....	17
8.1 General .....	17
8.2 Operating conditions .....	17
8.2.1 Pneumatic machines.....	17
8.2.2 Hydraulic machines.....	17
8.2.3 Electrical machines .....	18
8.3 Other quantities to be specified.....	18
8.4 Attached equipment, work piece and task.....	18
8.4.1 General .....	18
8.4.2 Test set-up, conditions and procedures .....	18
8.5 Operators.....	22
9 Measurement procedure and validity .....	23
9.1 Reported vibration values .....	23
9.2 Declaration and verification of the vibration emission value .....	23
10 Measurement report .....	24
Annex A (informative) Model test report for vibration emission of saws and files.....	25
Annex B (normative) Determination of uncertainty .....	27
Bibliography.....	29

## Foreword

ISO (the International Organization for Standardization) is a worldwide federation of national standards bodies (ISO member bodies). The work of preparing International Standards is normally carried out through ISO technical committees. Each member body interested in a subject for which a technical committee has been established has the right to be represented on that committee. International organizations, governmental and non-governmental, in liaison with ISO, also take part in the work. ISO collaborates closely with the International Electrotechnical Commission (IEC) on all matters of electrotechnical standardization.

International Standards are drafted in accordance with the rules given in the ISO/IEC Directives, Part 2.

The main task of technical committees is to prepare International Standards. Draft International Standards adopted by the technical committees are circulated to the member bodies for voting. Publication as an International Standard requires approval by at least 75 % of the member bodies casting a vote.

Attention is drawn to the possibility that some of the elements of this document may be the subject of patent rights. ISO shall not be held responsible for identifying any or all such patent rights.

ISO 28927-8 was prepared by Technical Committee ISO/TC 118, *Compressors and pneumatic tools, machines and equipment*, Subcommittee SC 3, *Pneumatic tools and machines*.

This first edition of ISO 28927-8 cancels and replaces ISO 8662-12:1997, of which it constitutes a technical revision. The most important changes are

- vibration measurement in three axes and at both hand positions,
- new transducer positions, and
- improved definition of transducer positions and orientation.

ISO 28927 consists of the following parts, under the general title *Hand-held portable power tools — Test methods for evaluation of vibration emission*:

- *Part 1: Angle and vertical grinders*<sup>1)</sup>
- *Part 2: Wrenches, nutrunners and screwdrivers*<sup>2)</sup>
- *Part 3: Polishers and rotary, orbital and random orbital sanders*<sup>3)</sup>
- *Part 4: Straight grinders*<sup>4)</sup>

---

1) Together with Part 4, replaces ISO 8662-4, *Hand-held portable power tools — Measurement of vibrations at the handle — Part 4: Grinders*.

2) Replaces ISO 8662-7, *Hand-held portable power tools — Measurement of vibrations at the handle — Part 7: Wrenches, screwdrivers nut runners with impact, impulse and ratcheting action*. All screwdrivers and nutrunners except for one-shot tools now covered.

3) Replaces ISO 8662-8, *Hand-held portable power tools — Measurement of vibrations at the handle — Part 8: Polishers and rotary, orbital and random orbital sanders*.

4) Together with Part 1, replaces ISO 8662-4, *Hand-held portable power tools — Measurement of vibrations at the handle — Part 4: Grinders*.

- Part 5: Drills and impact drills<sup>5)</sup>
- Part 6: Rammers<sup>6)</sup>
- Part 7: Nibblers and shears<sup>7)</sup>
- Part 8: Saws, polishing and filing machines with reciprocating action and small saws with oscillating or rotating action
- Part 9: Scaling hammers and needle scalers<sup>8)</sup>
- Part 10: Percussive drills, hammers and breakers<sup>9)</sup>
- Part 11: Stone hammers<sup>10)</sup>

iTeh STANDARD PREVIEW  
 (standards.iteh.ai)  
 Full standard:  
<https://standards.iteh.ai/catalog/standards/sist/e996b688-eeeb-4d9b-8a42-071971535174/iso-28927-8-2009-amd-1-2015>

---

5) Replaces ISO 8662-6, *Hand-held portable power tools — Measurement of vibrations at the handle — Part 6: Impact drills*. Non-impacting drills now covered.

6) Replaces ISO 8662-9, *Hand-held portable power tools — Measurement of vibrations at the handle — Part 9: Rammers*.

7) Replaces ISO 8662-10, *Hand-held portable power tools — Measurement of vibrations at the handle — Part 10: Nibblers and shears*.

8) Together with Part 11, replaces ISO 8662-14, *Hand-held portable power tools — Measurement of vibrations at the handle — Part 14: Stone-working tools and needle scalers*.

9) Replaces ISO 8662-2, *Hand-held portable power tools — Measurement of vibrations at the handle — Part 2: Chipping hammers and riveting hammers*, ISO 8662-3, *Hand-held portable power tools — Measurement of vibrations at the handle — Part 3: Rock drills and rotary hammers*, and ISO 8662-5, *Hand-held portable power tools — Measurement of vibrations at the handle — Part 5: Pavement breakers and hammers for construction work*. Chipping and riveting hammers, rock drills and rotary hammers all covered.

10) Together with Part 9, replaces ISO 8662-14, *Hand-held portable power tools — Measurement of vibrations at the handle — Part 14: Stone-working tools and needle scalers*.

## Introduction

This document is a type-C standard as stated in ISO 12100.

When requirements of this type-C standard are different from those which are stated in type-A or -B standards, the requirements of this type-C standard take precedence over the requirements of the other standards for machines that have been designed and built according to the requirements of this type-C standard.

The vibration test codes for portable hand-held machines given in ISO 28927 are based on ISO 20643, which gives general specifications for the measurement of the vibration emission of hand-held and hand-guided machinery. ISO 28927 specifies the operation of the machines under type-test conditions and other requirements for the performance of type tests. The structure/numbering of its clauses follows that of ISO 20643.

The basic principle for transducer positioning first introduced in the EN 60745 series of European standards is followed, representing a deviation from ISO 20643 for reasons of consistency. The transducers are primarily positioned next to the hand in the area between the thumb and the index finger, where they give the least disturbance to the operator gripping the machine.

It has been found that vibrations generated by files and saws vary considerably in typical use. For reciprocating saws and files, the motion of reciprocation is the prime source of vibration. The variation is largely due to variations in the handling of the machine and the characteristics of the material worked on, while differences in the support of the material and counterbalancing of the machine also cause differences in vibration.

This part of ISO 28927 uses a working process where the machine is used to cut sheet metal or wood. In order to achieve good reproducibility, it is important that the material have good support and that the files or saw blades used be in good condition. The procedures of ISO 5349 are required whenever exposure at the workplace is to be assessed.

The values obtained are type-test values intended to be representative of the average of the upper quartile of typical vibration magnitudes in real-world use of the machines. However, the actual magnitudes will vary considerably from time to time and depend on many factors, including the operator, the task and the inserted tool or consumable. The state of maintenance of the machine itself might also be of importance. Under real working conditions the influences of the operator and process can be particularly important at low magnitudes. It is therefore not recommended that emission values below  $2,5 \text{ m/s}^2$  be used for estimating the vibration magnitude under real working conditions. In such cases,  $2,5 \text{ m/s}^2$  is the recommended vibration magnitude for estimating the machine vibration.

If accurate values for a specific work place are required, then measurements (according to ISO 5349) in that work situation could be necessary. Vibration values measured in real working conditions can be either higher or lower than the values obtained using this part of ISO 28927.

Higher vibration magnitudes can easily occur in real working situations, depending on the characteristics of the material being worked on, the condition of the inserted tool and the handling of the machine.

The vibration test codes given in ISO 28927 supersede those given in ISO 8662, whose parts have been replaced by the corresponding parts of ISO 28927 (see Foreword).

NOTE ISO 8662-11, *Hand-held portable power tools — Measurement of vibrations at the handle — Part 11: Fastener driving tools*, and ISO 8662-13, *Hand-held portable power tools — Measurement of vibrations at the handle — Part 13: Die grinders*, could be replaced by future parts of ISO 28927.

# Hand-held portable power tools — Test methods for evaluation of vibration emission —

## Part 8:

### Saws, polishing and filing machines with reciprocating action and small saws with oscillating or rotating action

#### 1 Scope

This part of ISO 28927 specifies a laboratory method for measuring hand-transmitted vibration emission at the handles of hand-held, power-driven saws, polishing and filing machines with reciprocating action and small saws with oscillating or rotating action. It is a type-test procedure for establishing the magnitude of vibration in the gripping areas of a machine run under specified test conditions. It is intended that the results be used to compare different models of the same type of machine.

This part of ISO 28927 is applicable to reciprocating files intended for surface finishing equipped with a file or polishing tool, saws intended for parting sheets, plaster for medical use or wood, or equipped with a saw blade for use on all kinds of materials, and small circular saws primarily intended for cutting metal or composite materials (see Clause 5), whether driven pneumatically or by other means. It is not applicable to files that are normally used with one hand on the file blade, nor to large circular saws intended for cutting wood.

NOTE To avoid confusion with the terms “power tool” and “inserted tool”, *machine* is used for the former throughout this document.

#### 2 Normative references

The following referenced documents are indispensable for the application of this document. For dated references, only the edition cited applies. For undated references, the latest edition of the referenced document (including any amendments) applies.

ISO 2787:1984, *Rotary and percussive pneumatic tools — Performance tests*

ISO 5349:2001 (all parts), *Mechanical vibration — Measurement and evaluation of human exposure to hand-transmitted vibration*

ISO 5391:2003, *Pneumatic tools and machines — Vocabulary*

ISO 17066:2007, *Hydraulic tools — Vocabulary*

ISO 20643:2005, *Mechanical vibration — Hand-held and hand-guided machinery — Principles for evaluation of vibration emission*

EN 12096:1997, *Mechanical vibration — Declaration and verification of vibration emission values*

ISO 16893-1:2008, *Wood-based panels — Particleboard — Part 1: Classifications*



### 3 Terms, definitions and symbols

For the purposes of this document, the terms and definitions given in ISO 5391, ISO 17066 and ISO 20643, and the following terms, definitions and symbols, apply.

#### 3.1 Terms and definitions

##### 3.1.1

##### **circular saw**

machine equipped with a rotary saw blade

NOTE Adapted from ISO 5391:2003, definition 2.1.8.1.

##### 3.1.2

##### **oscillation saw**

machine equipped with a saw blade that moves with an angular reciprocating movement

##### 3.1.3

##### **reciprocating saw**

sabre saw

hack saw

machine with a rotary or reciprocating motor, adapted to drive a saw blade in a reciprocating motion

[ISO 5391:2003, definition 2.1.8.3]

##### 3.1.4

##### **jig saw**

saw with a reciprocating and pendulum motion

[ISO 5391:2003, definition 2.1.8.5]

##### 3.1.5

##### **reciprocating filing and polishing machine**

machine with a rotary and reciprocation motor that drives a file or polishing inserted tool in an angular or straight reciprocating motion

#### 3.2 Symbols

Symbol	Description	Unit
$a_{hw}$	root-mean-square (r.m.s.) single-axis acceleration value of the frequency-weighted hand-transmitted vibration	$m/s^2$
$a_{hv}$	vibration total value of frequency-weighted r.m.s. acceleration; root sum of squares of $a_{hw}$ values for the three measured axes of vibration	$m/s^2$
$\overline{a_{hv}}$	arithmetic mean value of $a_{hv}$ values of runs for single operator using one hand position	$m/s^2$
$a_h$	arithmetic mean value of $\overline{a_{hv}}$ values for all operators for one hand position	$m/s^2$
$\overline{a_h}$	arithmetic mean value of $a_h$ values for one hand position on several machines	$m/s^2$
$a_{hd}$	declared vibration emission value	$m/s^2$
$s_{n-1}$	standard deviation for a test series (for a sample, $s$ )	$m/s^2$
$\sigma_R$	standard deviation of reproducibility (for a population, $\sigma$ )	$m/s^2$
$C_v$	coefficient of variation for a test series	
$K$	uncertainty	$m/s^2$



## 4 Basic standards and vibration test codes

This part of ISO 28297 is based on the requirements of ISO 20643 and corresponds to its structure in respect of clause subjects and numbering except for the annexes.

Annex A presents a model test report and Annex B the means for determining the uncertainty,  $K$ .

## 5 Description of the family of machines

This part of ISO 29827 applies to hand-held machines intended for surface finishing, equipped with a file or polishing tool, and to hand-held machines intended for parting sheets, plaster for medical use or wood, or for use on all kinds of materials, and for cutting metal or composite materials.

Figures 1 to 14 show examples of typical saws, files and polishing machines covered by this part of ISO 29827.



Figure 1 — Straight oscillating saw



Figure 2 — Small circular saw

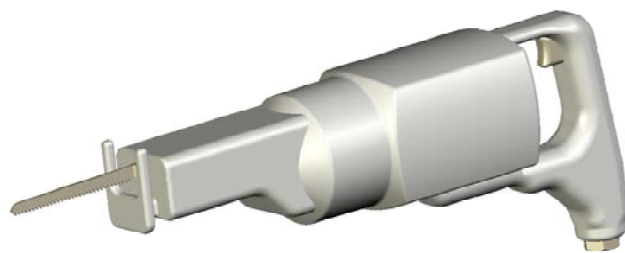

Figure 3 — Reciprocating saw with bow handle



Figure 4 — Reciprocating saw with pistol grip

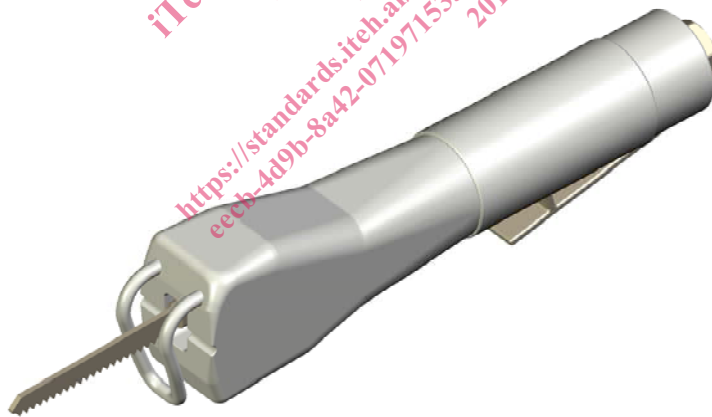

Figure 5 — Straight reciprocating saw

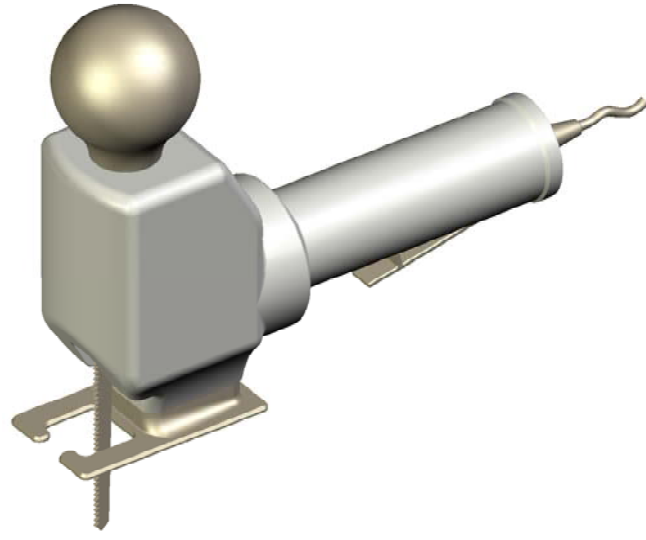

Figure 6 — Jig saw



Figure 7 — Straight polishing/filing machine with reciprocating action

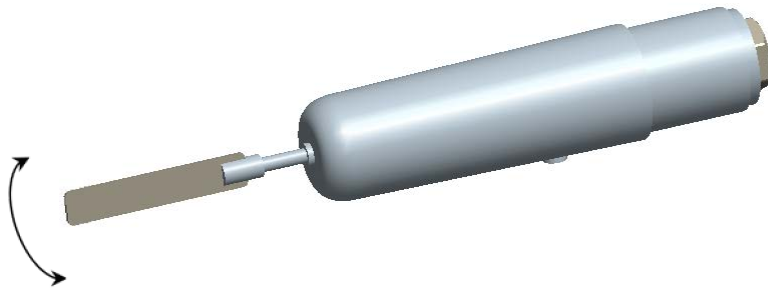

Figure 8 — Straight polishing/filing machine with transverse action