



Designation: D 4543 – 01

## Standard Practices for Preparing Rock Core Specimens and Determining Dimensional and Shape Tolerances<sup>1</sup>

This standard is issued under the fixed designation D 4543; the number immediately following the designation indicates the year of original adoption or, in the case of revision, the year of last revision. A number in parentheses indicates the year of last reapproval. A superscript epsilon ( $\epsilon$ ) indicates an editorial change since the last revision or reapproval.

### 1. Scope

1.1 This practice specifies procedures for determining the length and diameter of rock core specimens and the conformance of the dimensions with established standards.

1.2 Rock is a complex engineering material which can vary greatly as a function of lithology, stress history, weathering, and other natural geologic processes. As such, it is not always possible to obtain or prepare rock core specimens which satisfy the desirable criteria given in this practice. Most commonly, this situation presents itself with weaker, more porous, and poorly cemented rock types and rock types containing significant structural features. For these and other rock types which are difficult to prepare, all reasonable efforts shall be made to prepare a sample in accordance with this practice. However, when it has been determined by trial that this is not possible, prepare the rock specimen to the highest standard practicable and consider this to be the best effort and report it as such, with all appropriate size and dimensional measurements reported as in Section 6.

1.3 This practice also prescribes tolerance checks on the straightness of the elements on the cylindrical surface, the flatness of the end bearing surfaces, and the perpendicularity of the end surfaces with the axis of the core.

1.4 The requirement for specifying the moisture condition of the test specimen at the time of the test is also stated.

1.5 The values stated in inch-pound units are to be regarded as the standard. The SI units given in parentheses are for information only.

1.6 *This standard does not purport to address all of the safety concerns, if any, associated with its use. It is the responsibility of the user of this standard to establish appropriate safety and health practices and determine the applicability of regulatory limitations prior to use.*

1.7 *This practice offers a set of instructions for performing one or more specific operations. This document cannot replace education or experience and should be used in conjunction with professional judgement. Not all aspects of this practice may be applicable in all circumstances. This ASTM standard is*

*not intended to represent or replace the standard of care by which the adequacy of a given professional service must be judged, nor should this document be applied without consideration of a project's many unique aspects. The word "standard" in the title of this document means only that the document has been approved through the ASTM consensus process.*

### 2. Referenced Documents

#### 2.1 ASTM Standards:

- C 617 Practice for Capping Cylindrical Concrete Specimens<sup>2</sup>
- D 2113 Practice for Rock Core Drilling and Sampling of Rock for Site Investigation<sup>3</sup>
- D 2216 Test Method for Laboratory Determination of Water (Moisture) Content of Soil and Rock by Mass<sup>3</sup>
- D 2664 Test Method for Triaxial Compressive Strength of Undrained Rock Core Specimens without Pore Pressure Measurements<sup>3</sup>
- D 2936 Test Method for Direct Tensile Strength of Intact Rock Core Specimens<sup>3</sup>
- D 2938 Test Method for Unconfined Compressive Strength of Intact Rock Core Specimens<sup>3</sup>
- D 3148 Test Method for Elastic Moduli of Intact Rock Core Specimens in Uniaxial Compression<sup>3</sup>
- D 3740 Practice for Minimum Requirements for Agencies Engaged in the Testing and/or Inspection of Soil and Rock as Used in Engineering Design and Construction
- D 4341 Test Method for Creep of Cylindrical Hard Rock Core Specimens in Uniaxial Compression<sup>3</sup>
- D 4405 Test Method for Creep of Cylindrical Soft Rock Core Specimens in Uniaxial Compression<sup>3</sup>
- D 4406 Test Method for Creep of Cylindrical Rock Core Specimens in Triaxial Compression<sup>3</sup>

### 3. Significance and Use

3.1 The dimensional, shape, and surface tolerances of rock core specimens are important for determining rock properties of intact specimens. Dimensional and surface tolerance checks are required in the test methods listed in 2.1. To simplify test

<sup>1</sup> This practice is under the jurisdiction of ASTM Committee D18 on Soil and Rock and is the direct responsibility of Subcommittee D18.12 on Rock Mechanics.

Current edition approved June 10, 2001. Published November 2001. Originally published as D 4543–85. Last previous edition D 4543–85 (Reapproved 1991).

<sup>2</sup> *Annual Book of ASTM Standards*, Vol 04.02.

<sup>3</sup> *Annual Book of ASTM Standards*, Vol 04.08.

procedures in laboratories, the parts of those procedures that are common to the test methods are given in this standard.

**4. Specimens**

4.1 Test specimens shall be right circular cylinders within the tolerances specified herein.

4.2 The specimen shall have a length-to-diameter ratio (L/D) of 2.0 to 2.5 and a diameter of not less than 1 7/8 in. (47 mm).

NOTE 1—It is desirable that the diameter of rock test specimens be at least ten times the diameter of the largest mineral grain. For weak rock types which behave more like soil (for example, weakly cemented sandstone), the specimen diameter should be at least six times the maximum particle diameter. It is considered that the specified minimum specimen diameter of approximately 1 7/8 in. (47 mm) will satisfy this criterion in the majority of cases. When cores of diameter smaller than the specified minimum must be tested because of the unavailability of larger diameter core, as is often the case in the mining industry, suitable notation of this fact shall be made in the report.

4.4 The ends of the specimen shall be cut parallel to each other and at right angles to the longitudinal axis. The end surfaces shall be surface ground or lapped flat to a tolerance not to exceed 0.001 in. (25 μm), as determined by 5.2.<sup>4</sup>

**5. Procedure**

5.1 Determine the deviation from straightness of the elements by either Procedure A or Procedure B, as follows:

5.1.1 *Procedure A*—Roll the cylindrical specimen on a smooth, flat surface and measure the height of the maximum gap between the specimen and the flat surface with a feeler gage. If the maximum gap exceeds 0.020 in. (0.50 mm), the specimen does not meet the required tolerance for straightness of the elements. The flat test surface on which the specimen is rolled shall not depart from a plane by more than 0.0005 in. (13 μm).

5.1.2 *Procedure B*—Place the cylindrical surface of the specimen on a V-block that is laid flat on a support surface. The V-block shall be machinist quality with all bearing faces surface ground and with a 90° included angle. Maintain the support surface and all bearing surfaces on the V-block flat and smooth to within 0.0005 in. (13 μm). The length of the V-block shall be sufficient that the specimen will not project over its ends during movement.

5.1.2.1 Place a dial gage in contact with the top of the specimen, as shown in Fig. 1, and observe the dial reading as the specimen is moved from one end of the V-block to the other along a straight line, without rotation. The sensitivity of the dial gage shall be at least 0.001 in. (25 μm). The measurement contact tip of the dial gage shall be round in shape.

5.1.2.2 Record the maximum and minimum readings on the dial gage and calculate the difference, Δ<sub>0</sub>. If the dial gage traverses a natural cavity in the rock, readings in this region should not be included in the determination of Δ<sub>0</sub>. Repeat the same operations by rotating the specimen for every 120°, and obtain the differences Δ<sub>120</sub> and Δ<sub>240</sub>. The maximum value of these three differences shall be less than 0.020 in. (0.50 mm).

5.2 Check the end flatness tolerance by either Procedure A or Procedure B, as follows:

5.2.1 *Procedure A*—Place the specimen in a setup similar to that for the cylindrical surface (Fig. 2) except that the dial gage shall be mounted near the end of the V-block.

5.2.1.1 Move the mounting pad horizontally so that the dial gage measurement tip runs across a diameter of the specimen end surface. Make sure that the end of the mounting pad maintains intimate contact with the end surface of the V-block during movement. A dial gage readable to 0.0001 in. (2.5 μm) is required for measurements on the end surfaces.

5.2.1.2 Record the dial gage readings every 1/8 in. (3 mm) across the diameter. These readings may be recorded in tabular form, or to simplify the procedure, they may be plotted directly on a graph as shown for End 1, Diameter 1, in Fig. 3. Data recording is simplified if the dial gage is set to zero when it is in contact with the center of the end face.

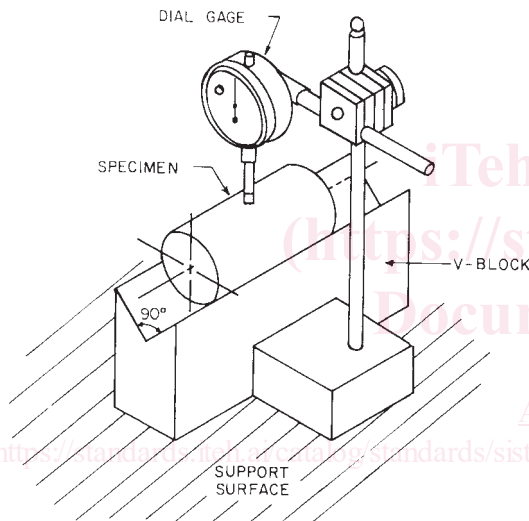

**FIG. 1 Assembly for Determining the Straightness of Elements on the Cylindrical Surface—Procedure B**

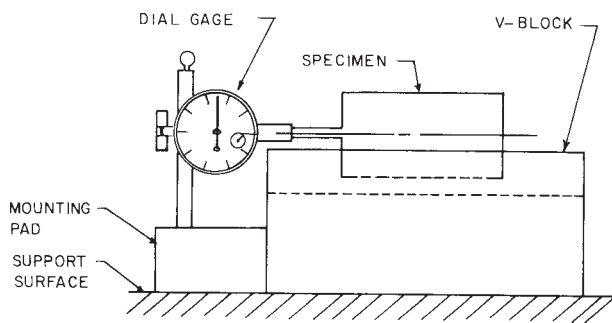

**FIG. 2 Assembly for Determining the Flatness and Perpendicularity of End Surfaces to the Specimen Axis—Procedure B**

4.3 The sides of the specimen shall be generally smooth and free of abrupt irregularities, with all the elements straight to within 0.020 in. (0.50 mm) over the full length of the specimen, as determined by 5.1.

<sup>4</sup> Hoskins, J. R., and Horino, F. G., "Effects of End Conditions on Determining Compressive Strength of Rock Samples," *Report of Investigations U.S. Bureau of Mines 7171*, 1968.