**Timber structures — Uniform,
concentrated static and concentrated
impact loads on wood-based roof and
floor panel assemblies — Test methods**

*Structures en bois — Assemblages de panneaux en bois pour toitures
et planchers sous charges concentrées et réparties, statique et par
impact — Méthodes d'essais*

iTeh STANDARD PREVIEW
(standards.iteh.ai)

ISO 16507:2013

<https://standards.iteh.ai/catalog/standards/sist/65c84f63-10cd-48a1-ad89-9e332cc87382/iso-16507-2013>



iTeh STANDARD PREVIEW
(standards.iteh.ai)

ISO 16507:2013

<https://standards.iteh.ai/catalog/standards/sist/65c84f63-10cd-48a1-ad89-9e332cc87382/iso-16507-2013>



COPYRIGHT PROTECTED DOCUMENT

© ISO 2013

All rights reserved. Unless otherwise specified, no part of this publication may be reproduced or utilized otherwise in any form or by any means, electronic or mechanical, including photocopying, or posting on the internet or an intranet, without prior written permission. Permission can be requested from either ISO at the address below or ISO's member body in the country of the requester.

ISO copyright office
Case postale 56 • CH-1211 Geneva 20
Tel. + 41 22 749 01 11
Fax + 41 22 749 09 47
E-mail copyright@iso.org
Web www.iso.org

Published in Switzerland

Contents

	Page
Foreword	iv
Introduction	v
1 Scope	1
2 Normative references	1
3 Terms and definitions	1
4 Symbols	2
5 Specimen conditioning	2
5.1 Dry.....	2
5.2 Wet.....	2
5.3 Redried.....	2
6 Concentrated static load test	2
6.1 Apparatus.....	2
6.2 Specimen preparation.....	4
6.3 Procedure.....	7
6.4 Report.....	7
7 Concentrated impact load test	8
7.1 Apparatus.....	8
7.2 Specimen preparation.....	11
7.3 Procedure.....	11
7.4 Report.....	13
8 Uniformly distributed load test	14
8.1 General.....	14
8.2 Apparatus.....	14
8.3 Specimen preparation.....	15
8.4 Test procedure.....	16
8.5 Report.....	17
Annex A (informative) Structural performance requirements for span rating	18
Bibliography	22

Foreword

ISO (the International Organization for Standardization) is a worldwide federation of national standards bodies (ISO member bodies). The work of preparing International Standards is normally carried out through ISO technical committees. Each member body interested in a subject for which a technical committee has been established has the right to be represented on that committee. International organizations, governmental and non-governmental, in liaison with ISO, also take part in the work. ISO collaborates closely with the International Electrotechnical Commission (IEC) on all matters of electrotechnical standardization.

The procedures used to develop this document and those intended for its further maintenance are described in the ISO/IEC Directives, Part 1. In particular the different approval criteria needed for the different types of ISO documents should be noted. This document was drafted in accordance with the editorial rules of the ISO/IEC Directives, Part 2 (see www.iso.org/directives).

Attention is drawn to the possibility that some of the elements of this document may be the subject of patent rights. ISO shall not be held responsible for identifying any or all such patent rights. Details of any patent rights identified during the development of the document will be in the Introduction and/or on the ISO list of patent declarations received (see www.iso.org/patents).

Any trade name used in this document is information given for the convenience of users and does not constitute an endorsement.

For an explanation on the meaning of ISO specific terms and expressions related to conformity assessment, as well as information about ISO's adherence to the WTO principles in the Technical Barriers to Trade (TBT) see the following URL: Foreword - Supplementary information

The committee responsible for this document is ISO/TC 165, *Timber structures*.

[ISO 16507:2013](https://standards.iteh.ai/catalog/standards/sist/65c84f63-10cd-48a1-ad89-9e332cc87382/iso-16507-2013)

<https://standards.iteh.ai/catalog/standards/sist/65c84f63-10cd-48a1-ad89-9e332cc87382/iso-16507-2013>

Introduction

During construction and occupancy of a building, floor and roof sheathing are subjected to uniform and concentrated static and impact loads that frequently govern the thickness required. Static loads may simulate either foot traffic, or loads from fixtures, when applied through loading disks of appropriate size. Impact loads will occur during construction and also in service. Uniform loads may simulate snow, wind, or occupancy loads.

Roof sheathing and subflooring are likely to be critical in strength or stiffness, or both, under foot traffic and construction loads, while single-layer floors are generally critical under fixture loads, foot traffic, and in-service impact loads. Subfloors, like single floors, must also support fixture loads, but they will have an additional layer of material, such as underlayment above, which will help to distribute concentrated loads.

The procedures outlined will provide data that can be used to evaluate the structural performance, under concentrated and uniform loads, of roof and floor sheathing, separate from the effects of the framing, under simulated conditions representative of those in actual service.

The concentrated static and impact test procedures are based upon ASTM E661-03^[5]. The uniformly distributed load test is based upon NIST Voluntary Product Standard PS 1-09^[3].

[Annex A](#) contains non-mandatory sampling and product performance guidelines that correspond to span rating categories found in PS 1, PS 2, and CSA O325. These three structural wood-based panel standards have been referenced in North American building codes for several decades. Over this period of time, the performance guidelines established in these standards have resulted in reliable and satisfactory in-service structural performance.

(standards.iteh.ai)

ISO 16507:2013

<https://standards.iteh.ai/catalog/standards/sist/65c84f63-10cd-48a1-ad89-9e332cc87382/iso-16507-2013>

iTeh STANDARD PREVIEW
(standards.iteh.ai)

ISO 16507:2013

<https://standards.iteh.ai/catalog/standards/sist/65c84f63-10cd-48a1-ad89-9e332cc87382/iso-16507-2013>

Timber structures — Uniform, concentrated static and concentrated impact loads on wood-based roof and floor panel assemblies — Test methods

1 Scope

This International Standard is applicable to determining the resistance to deflection and damage of wood-based panels subjected to concentrated impact loads from nonrigid blunt objects, concentrated static loads, and uniformly distributed loads. Surface indentation is not evaluated separately from deflection.

The procedures are intended to simulate loading on roof or floor sheathing materials installed directly to framing. Three applications are covered: roof sheathing, subfloors, and single floors. Panels are tested parallel and/or perpendicular to the panel strength axis. Roof sheathing is tested in both a dry and a wet condition, while subfloors and single floors are both tested in a dry condition, as well as a condition of having dried out after being wet. These moisture conditions are those commonly experienced with site-built construction.

These procedures do not cover vibration and are not intended for the evaluation of the framed assembly as a whole.

iTeh STANDARD PREVIEW

2 Normative references (standards.iteh.ai)

The following documents, in whole or in part, are normatively referenced in this document and are indispensable for its application. For dated references, only the edition cited applies. For undated references, the latest edition of the referenced document (including any amendments) applies.

None.

3 Terms and definitions

For the purposes of this document, the following terms and definitions apply.

3.1 subfloor

panel that provides the structural integrity of the floor and is directly fastened to the floor framing, in conventional timber framing

3.2 underlayment

panel that provides a smooth surface for direct installation of non-structural finish floor covering, in conventional timber framing

3.3 single floor

panel that performs the function of subfloor and underlayment

3.4 span rating

index number, based on customary inch units, that identifies the recommended maximum centre-to-centre support spacing for the specified end use under normal use conditions

Note 1 to entry: Spans are defined for end uses such as roof, subfloor, and single floor. As a matter of convention, spans are typically specified by a single index number for single floor (e.g. Floor 24 o.c.), while roof and subfloor are often combined in a fractional format (e.g. 32/16).

EXAMPLE A span rating of 32/16 designates a roof span of 813 mm (32 inches) and a subfloor span of 406 mm (16 inches).

4 Symbols

d distance from outer support to the point of maximum deflection for a uniformly loaded two-span system, in mm

S test assembly span as measured from centre to centre of supports, in mm

W specimen width, in mm

5 Specimen conditioning

5.1 Dry

Conditioning to either constant weight or moisture content, or for at least 2 weeks at (20 ± 2) °C and (65 ± 5) % relative humidity.

NOTE 1 [Tables A.1](#) and [A.2](#), footnote a contain alternate conditions for Dry.

NOTE 2 The conditions specified in [5.1](#) may result in higher results than the conditions permitted for Dry in [Tables A.1](#) and [A.2](#), footnote a.

iTeh STANDARD PREVIEW
(standards.iteh.ai)

5.2 Wet

Conditioning to a continuous water spray for three days, applied to the top surface of the specimen at a rate such as to keep this surface continuously wet. The position of the specimen shall preclude water ponding on it, or immersion of any portion.

NOTE A simplified spray tank may be used to support the sheathing in a near vertical position during exposure to the water spray. The tank should be fitted with drains so that water spray does not accumulate, and the sheathing should be placed on blocks to elevate its lower edge above the residual water in the tank bottom.

5.3 Redried

Wet conditioning per [5.2](#) followed by dry conditioning per [5.1](#).

NOTE The use of a fan is recommended in order to dry specimens to a constant weight or moisture content.

6 Concentrated static load test

6.1 Apparatus

The apparatus for the concentrated load test shall conform to [Figure 1](#) and [6.1.1](#) to [6.1.4](#). Alternative methods for measuring deflection shall be permitted (see [6.1.4](#)).

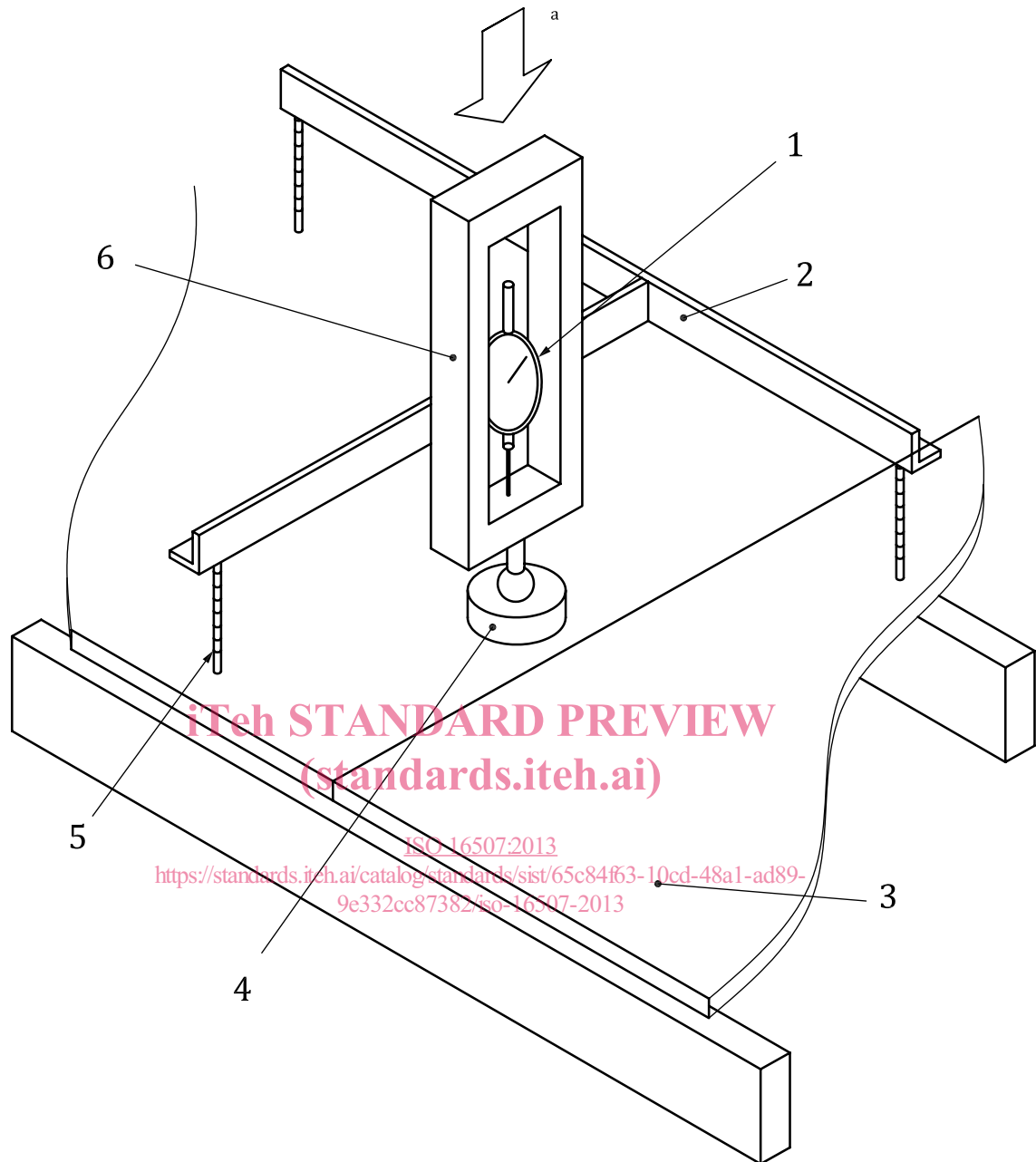

Key

- 1 dial gauge
- 2 dial gauge support
- 3 test specimen
- 4 loading disk (self-aligning)
- 5 threaded rod (height adjustable)
- 6 loading yoke
- a Load.

Figure 1 — Concentrated static and impact load apparatus

6.1.1 Supports

The framing members shall be supported in order not to deflect under the applied loads. The support system shall include provisions for rigidly restraining the ends of the framing members, to prevent rotation or vertical movement during testing.

6.1.2 Loading device

Any convenient means may be used for applying a compressive load up to ultimate, and for measuring the load within 1 % accuracy. Load shall be applied through a ball-and-socket joint to ensure even application.

6.1.3 Loading disk

Two steel disks are required: one having a diameter of 25 mm, representing a concentrated load, and one of 76 mm, representing foot traffic, each with a thickness of at least 13 mm. The edge of the loading disk contacting the test specimen shall be rounded to a radius not exceeding 1,5 mm. Disk diameters in [Table 1](#) shall be used for evaluating strength per [6.3.2](#). The 76-mm-diameter disk shall be used for evaluating stiffness per [6.3.1](#).

Table 1 — Disk diameters for concentrated load strength

Dimensions in millimetres

Conditioning	Application		
	Roof	Subfloor	Single floor
Wet	76	76 ^a	76 ^a
Dry	76	76	25
Redried		76	25

^a Testing in the wet condition for subfloors and single floors is not common, and is not required in [Annex A](#).

6.1.4 Deflection gauge

The deflection gauge shall be mounted on a rigid tripod whose legs rest on the sheathing immediately above the framing members that are adjacent to the load point ([Figure 1](#)). Alternatively, other deflection measuring devices capable of measuring panel deflection separately from deformation of the test apparatus (e.g. supporting frame, load head, etc.) shall be permitted. The deflection gauge shall have a range exceeding the maximum anticipated deflection, have a maximum error of less than 1 %, and have a resolution not more than 0,03 mm.

6.2 Specimen preparation

The specimen shall be installed and its test points are located in the framing assembly per [Figure 2](#). The specimen length perpendicular to the main framing members shall conform to the centre-to-centre spacing, *S*, anticipated in service. Where sheathing is continuous over more than one span, its length shall be equal to the minimum number of spans permitted or recommended for the product used and its intended application, multiplied by the centre-to-centre spacing of the framing members.

The specimen width shall be at least 595 mm for spans up to 610 mm. For greater spans, the specimen width shall be either 1 220 mm or the full panel width, which ever is less. The specimen width shall conform to its nominal full panel width when edges are fully supported. When edges are unsupported or partially supported, the specimen may be trimmed to a width not less than 595 mm.

The specimen shall be cut to the required size prior to conditioning. The specimen shall be conditioned to either dry, wet, or redried (see [5.1](#) to [5.3](#)).

The conditioned specimen shall be installed using the type of framing, fastener schedule, and installation details as planned for use in service. After fabrication, test specimens promptly at ambient laboratory conditions.

Specimens may be used for more than one test provided the test locations are at least 455 mm apart (measured parallel to the framing), occur in different spans (see [Figure 2](#)), and show no sign of damage from other tests.

NOTE 1 [Annex A](#) contains recommended specimen conditioning requirements

NOTE 2 Where the specimen is installed on wood framing, the framing may be of any species and grade commonly used in construction that has a specific gravity of 0,40 to 0,70, oven-dry basis, with a maximum moisture content of 19 %. If nails are used, they may be double-headed to simplify the disassembly of the specimen upon completion of testing, providing such nails will not damage the testing equipment. Framing may be reused for more than one test, provided it has not been significantly damaged by previous testing. Steel framing and cleats simulating nails may be used instead of wood framing.

iTeh STANDARD PREVIEW
(standards.iteh.ai)

[ISO 16507:2013](#)

<https://standards.iteh.ai/catalog/standards/sist/65c84f63-10cd-48a1-ad89-9e332cc87382/iso-16507-2013>

Dimensions in millimetres

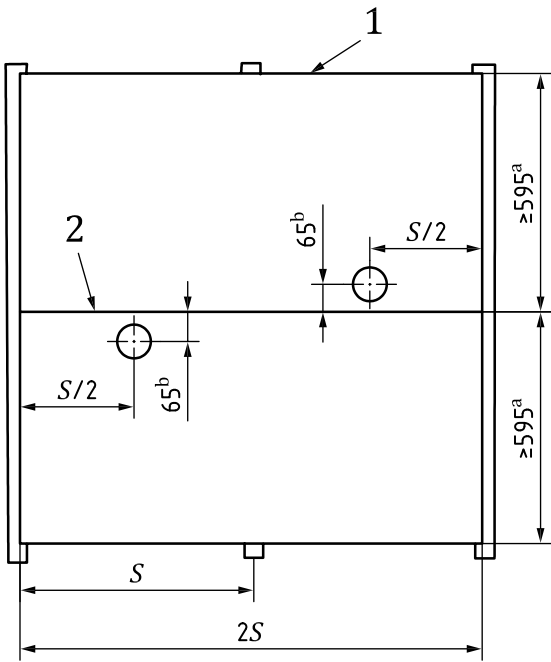

a) Edges partially supported

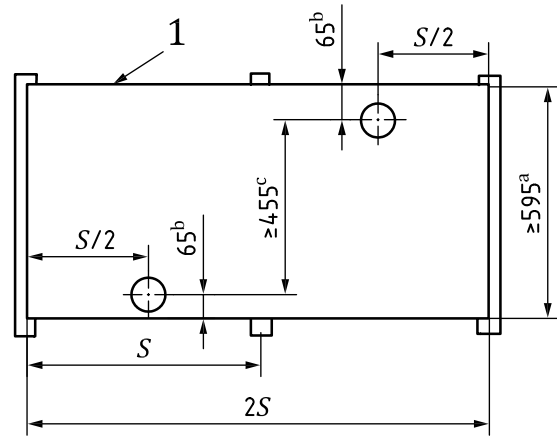

b) Edges not supported

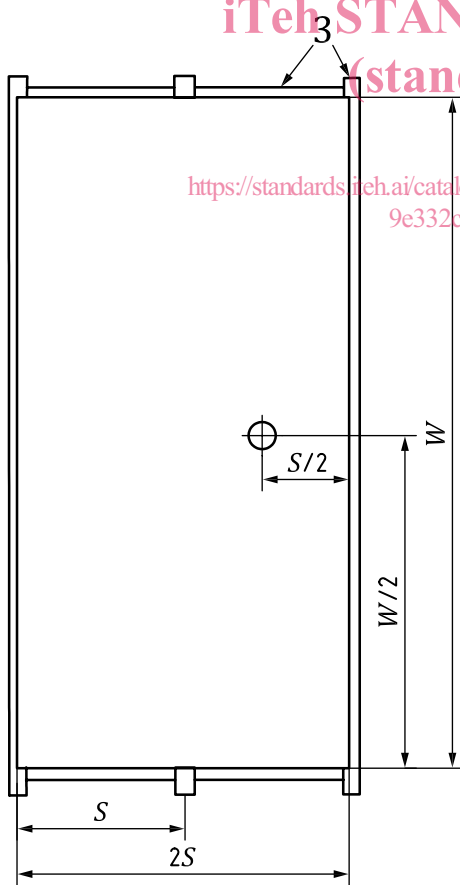

c) Edges fully supported

iTeh STANDARD PREVIEW
(standards.iteh.ai)

ISO 16507:2013
<https://standards.iteh.ai/catalog/standard/sist/65c84f63-10cd-48a1-ad89-9e332cc87382/iso-16507-2013>

