



Designation: D7136/D7136M-05<sup>ε1</sup> Designation: D 7136/D 7136M – 07

## Standard Test Method for Measuring the Damage Resistance of a Fiber-Reinforced Polymer Matrix Composite to a Drop-Weight Impact Event<sup>1</sup>

This standard is issued under the fixed designation D 7136/D 7136M; the number immediately following the designation indicates the year of original adoption or, in the case of revision, the year of last revision. A number in parentheses indicates the year of last reapproval. A superscript epsilon ( $\epsilon$ ) indicates an editorial change since the last revision or reapproval.

<sup>ε1</sup>Note—Fig.8 was editorially corrected in May 2005.

### 1. Scope

1.1 This test method covers/determines the damage resistance of multidirectional polymer matrix composite laminated plates subjected to a drop-weight impact event. The composite material forms are limited to continuous-fiber reinforced polymer matrix composites, with the range of acceptable test laminates and thicknesses defined in 8.2.

1.2 A flat, rectangular composite plate is subjected to an out-of-plane, concentrated impact using a drop-weight device with a hemispherical impactor. The potential energy of the drop-weight, as defined by the mass and drop height of the impactor, is specified prior to test. Equipment and procedures are provided for optional measurement of contact force and velocity during the impact event. The damage resistance is quantified in terms of the resulting size and type of damage in the specimen.

1.3 The test method may be used to screen materials for damage resistance, or to inflict damage into a specimen for subsequent damage tolerance testing. When the impacted plate is tested in accordance with Test Method D 7137/D 7137M, the overall test sequence is commonly referred to as the Compression After Impact (CAI) method. Quasi-static indentation per Test Method D 6264 may be used as an alternate method of creating damage from an out-of-plane force and measuring damage resistance properties.

1.4 The damage resistance properties generated by this test method are highly dependent upon several factors, which include specimen geometry, layup, impactor geometry, impactor mass, impact force, impact energy, and boundary conditions. Thus, results are generally not scalable to other configurations, and are particular to the combination of geometric and physical conditions tested.

1.5 The values stated in either SI units or inch-pound units are to be regarded separately as standard. Within the text the inch-pound units are shown in brackets. The values stated in each system are not exact equivalents; therefore, each system must be used independently of the other. Combining values from the two systems may result in nonconformance with the standard.

1.6 *This standard does not purport to address all of the safety concerns, if any, associated with its use. It is the responsibility of the user of this standard to establish appropriate safety and health practices and determine the applicability of regulatory limitations prior to use.*

### 2. Referenced Documents

#### 2.1 ASTM Standards:<sup>2</sup>

D 792 Test Methods for Density and Specific Gravity (Relative Density) of Plastics by Displacement

D 883 Terminology Relating to Plastics

D 3171 Test Methods for Constituent Content of Composite Materials

D 3763 Test Method for High Speed Puncture Properties of Plastics using Load and Displacement Sensors

D 3878 Terminology for Composite Materials

D 5229/D 5229M Test Method for Moisture Absorption Properties and Equilibrium Conditioning of Polymer Matrix Composite Laminates

D 5687/D 5687M Guide for Preparation of Flat Composite Panels with Processing Guidelines for Specimen Preparation

D 6264 Test Method for Measuring the Damage Resistance of a Fiber-Reinforced Polymer-Matrix Composite to a Concentrated Quasi-Static Indentation Force

D 7137/D 7137M Test Method for Compressive Residual Strength Properties of Damaged Polymer Matrix Composite Plates

E 4 Practices for Force Verification of Testing Machines

<sup>1</sup> This test method is under the jurisdiction of ASTM Committee D30 on Composite Materials and is the direct responsibility of Subcommittee D30.05 on Structural Test Methods.

Current edition approved April 1, 2005. Published April 2005.

Current edition approved Oct. 1, 2007. Published November 2007. Originally approved in 2005. Last previous edition approved in 2005 as D 7136/D 7136M - 05 <sup>ε1</sup>.

<sup>2</sup> For referenced ASTM standards, visit the ASTM website, [www.astm.org](http://www.astm.org), or contact ASTM Customer Service at [service@astm.org](mailto:service@astm.org). For *Annual Book of ASTM Standards* volume information, refer to the standard's Document Summary page on the ASTM website.

- E 6 Terminology Relating to Methods of Mechanical Testing
- E 18 Test Methods for Rockwell Hardness and Rockwell Superficial Hardness of Metallic Materials
- E 122 Practice for Calculation of Sample Size to Estimate, with a Specified Tolerable Error, the Average of Characteristic for a Lot or Process
- E 177 Practice for Use of the Terms Precision and Bias in ASTM Test Methods
- E 456 Terminology Relating to Quality and Statistics
- E 1309 Guide for Identification of Fiber-Reinforced Polymer Matrix Composite Materials in Databases
- ~~E 1434 Guide for Recording Mechanical Test Data of Fiber-Reinforced Composite Materials in Databases~~
- ~~E 1471 Guide for Identification of Fibers, Fillers and Core Materials in Computerized Material Property Databases~~ Guide for Recording Mechanical Test Data of Fiber-Reinforced Composite Materials in Databases

## 2.2 Military Standards:

- MIL-HDBK-17-3F Composite Materials Handbook, Volume 3—Polymer Matrix Composites Materials Usage, Design and Analysis<sup>3</sup>
- MIL-HDBK-728/1 Nondestructive Testing<sup>4</sup>
- MIL-HDBK-731A Nondestructive Testing Methods of Composite Materials—Thermography<sup>4</sup>
- MIL-HDBK-732A Nondestructive Testing Methods of Composite Materials—Acoustic Emission<sup>4</sup>
- MIL-HDBK-733A Nondestructive Testing Methods of Composite Materials—Radiography<sup>4</sup>
- MIL-HDBK-787A Nondestructive Testing Methods of Composite Materials—Ultrasonics<sup>4</sup>
- NASA Reference Publication 1092 Standard Tests for Toughened Resin Composites, Revised Edition, July 1983<sup>5</sup>

## 3. Terminology

3.1 *Definitions*—Terminology D 3878 defines terms relating to composite materials. Terminology D 883 defines terms relating to plastics. Terminology E 6 defines terms relating to mechanical testing. Terminology E 456 and Practice E 177 define terms relating to statistics. In the event of a conflict between terms, Terminology D 3878 shall have precedence over the other standards.

3.2 *Definitions of Terms Specific to This Standard*— If the term represents a physical quantity, its analytical dimensions are stated immediately following the term (or letter symbol) in fundamental dimension form, using the following ASTM standard symbology for fundamental dimensions, shown within square brackets:  $[M]$  for mass,  $[L]$  for length,  $[T]$  for time,  $[\theta]$  for thermodynamic temperature, and  $[nd]$  for non-dimensional quantities. Use of these symbols is restricted to analytical dimensions when used with square brackets, as the symbols may have other definitions when used without the brackets.

3.2.1 *dent depth,  $d$   $[L]$ ,  $n$* —residual depth of the depression formed by an impactor after the impact event. The dent depth shall be defined as the maximum distance in a direction normal to the face of the specimen from the lowest point in the dent to the plane of the impacted surface that is undisturbed by the dent.

3.2.2 *nominal value,  $n$* —a value, existing in name only, assigned to a measurable property for the purpose of convenient designation. Tolerances may be applied to a nominal value to define an acceptable range for the property.

3.2.3 *principal material coordinate system,  $n$* —a coordinate system with axes that are normal to the planes of symmetry inherent to a material.

3.2.3.1 *Discussion*—Common usage, at least for Cartesian axes ( $123$ ,  $xyz$ , and so forth), generally assigns the coordinate system axes to the normal directions of planes of symmetry in order that the highest property value in a normal direction (for elastic properties, the axis of greatest stiffness) would be 1 or  $x$ , and the lowest (if applicable) would be 3 or  $z$ . Anisotropic materials do not have a principal material coordinate system due to the total lack of symmetry, while, for isotropic materials, any coordinate system is a principal material coordinate system. In laminated composites, the principal material coordinate system has meaning only with respect to an individual orthotropic lamina. The related term for laminated composites is “reference coordinate system.”

3.2.4 *recorded contact force,  $F$   $[MLT^{-2}]$ ,  $n$* —the force exerted by the impactor on the specimen during the impact event, as recorded by a force indicator.

3.2.5 *reference coordinate system,  $n$* —a coordinate system for laminated composites used to define ply orientations. One of the reference coordinate system axes (normally the Cartesian  $x$ -axis) is designated the reference axis, assigned a position, and the ply principal axis of each ply in the laminate is referenced relative to the reference axis to define the ply orientation for that ply.

3.2.6 *striker tip,  $n$* —the portion or component of the impactor which comes into contact with the test specimen first during the impact event.

## 3.3 Symbols:

$A$  = cross-sectional area of a specimen

$C_E$  = specified ratio of impact energy to specimen thickness

$CV$  = coefficient of variation statistic of a sample population for a given property (in percent)

$D$  = damage diameter (see Fig. 11)

<sup>3</sup> Available from U.S. Army Research Laboratory, Materials Directorate, Aberdeen Proving Ground, MD 21001.

<sup>4</sup> Available from U.S. Army Materials Technology Laboratory, Watertown, MA 02471.

<sup>5</sup> Available from National Aeronautics and Space Administration (NASA)-Langley Research Center, Hampton, VA 23681-2199.

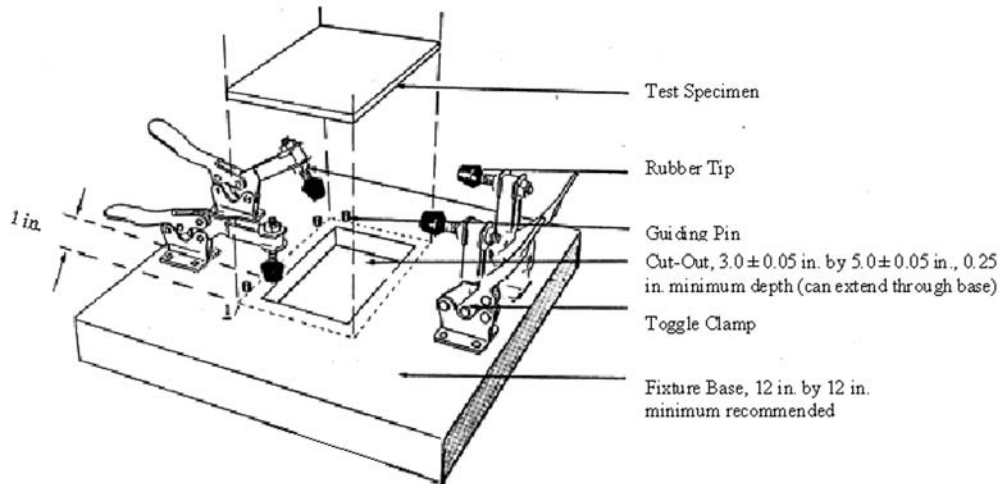

NOTE—Clamp tip centered 0.25 in. from edge of cut-out.  
**FIG. 1 Impact Support Fixture (Inch-Pound Version)**

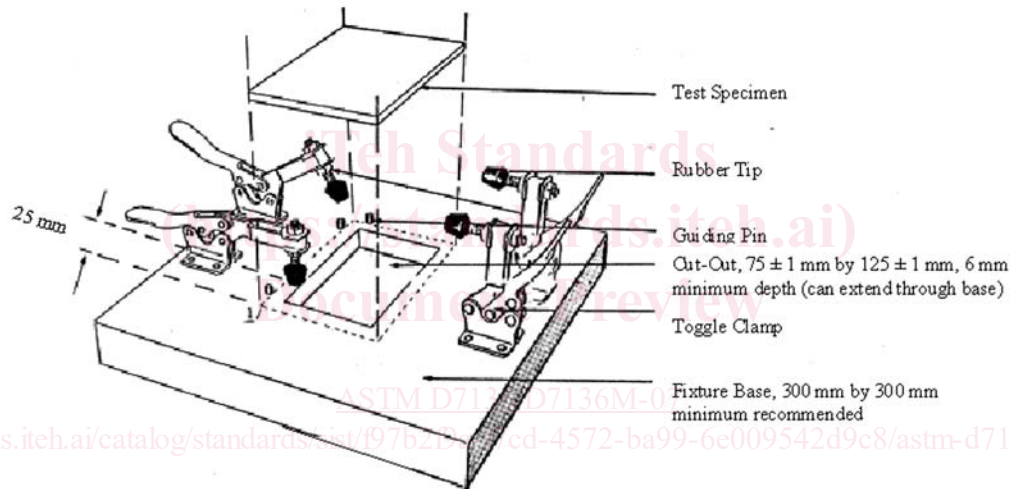

NOTE—Clamp tip centered 6 mm from edge of cut-out.  
**FIG. 2 Impact Support Fixture (SI Version)**

$d$  = dent depth

$E$  = potential energy of impactor prior to drop

$E_1$  = absorbed energy at the time at which force versus time curve has a discontinuity in force or slope

$E_a$  = energy absorbed by the specimen during the impact event

$E_i$  = actual impact energy (incident kinetic energy)

$E_{max}$  = absorbed energy at the time of maximum recorded contact force

$F$  = recorded contact force

$F_1$  = recorded contact force at which the force versus time curve has a discontinuity in force or slope

$F_{max}$  = maximum recorded contact force

$g$  = acceleration due to gravity

$h$  = specimen thickness

$H$  = impactor drop height

$l$  = specimen length

$m$  = impactor mass

$m_d$  = impactor mass for drop height calculation

$m_{dlbm}$  = impactor mass in standard gravity for drop height calculation

$n$  = number of specimens per sample population

$N$  = number of plies in laminate under test

$S_{n-1}$  = standard deviation statistic of a sample population for a given property

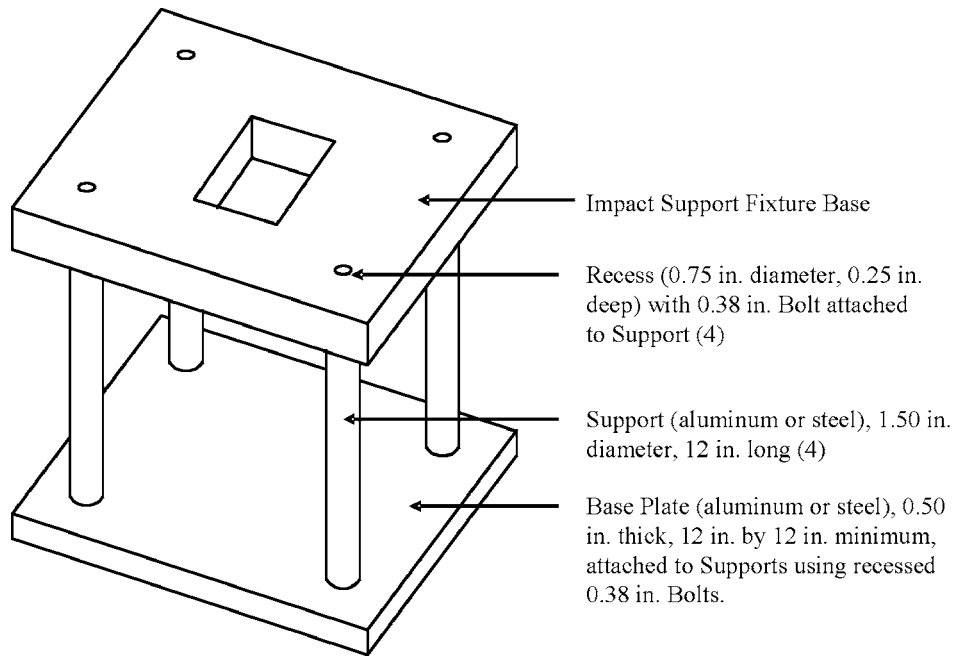

FIG. 3 Representative Rigid Base (Inch-Pound Version)

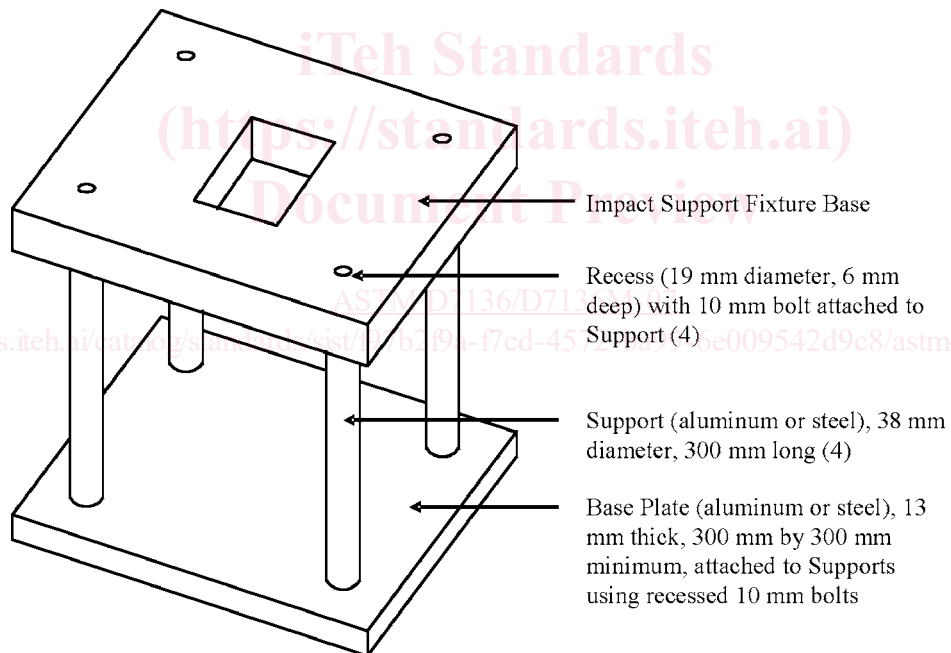

FIG. 4 Representative Rigid Base (SI Version)

$t$  = time during impactor drop and impact event

$t_i$  = time of initial contact

$t_T$  = contact duration (total duration of the impact event)

$w$  = specimen width

$v$  = impactor velocity

$v_i$  = impactor velocity at time of initial contact,  $t_i$

$W_{12}$  = distance between leading edges of the two flag prongs on velocity indicator

$x_i$  = test result for an individual specimen from the sample population for a given property

$\bar{x}$  = mean or average (estimate of mean) of a sample population for a given property

$\delta$  = impactor displacement

Impactor is placed within tube and set to selected drop height prior to impact.

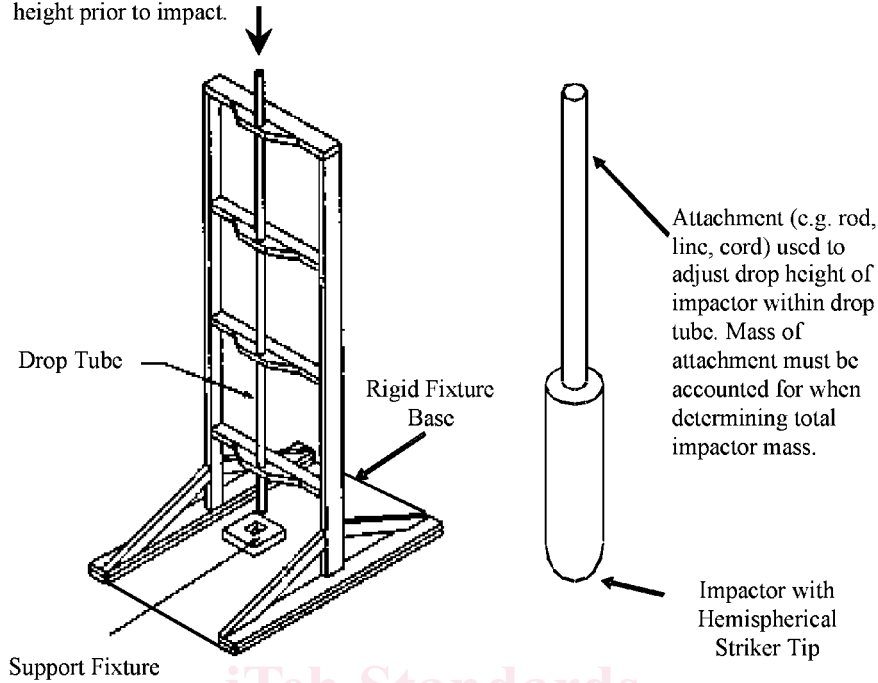

FIG. 5 Impact Device with Cylindrical Tube Impactor Guide Mechanism

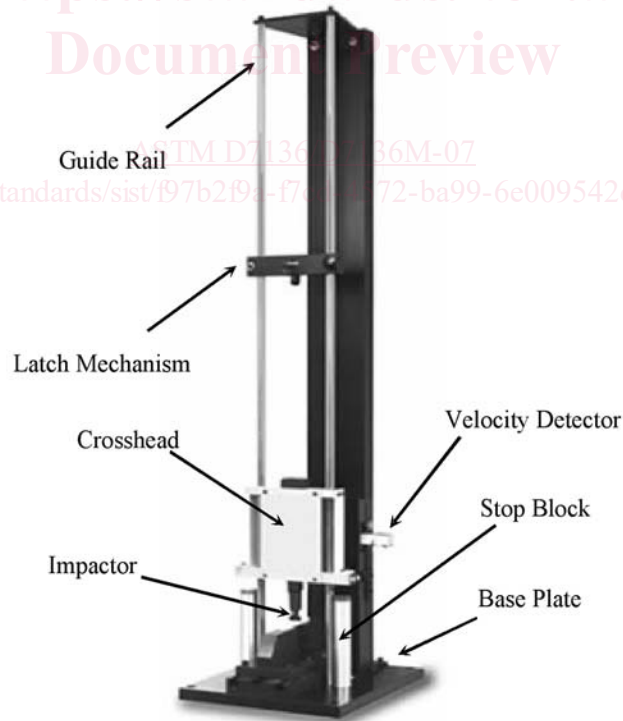

FIG. 6 Impact Device with Double Column Impactor Guide Mechanism

#### 4. Summary of Test Method

4.1 A drop-weight impact test is performed using a balanced, symmetric laminated plate. Damage is imparted through out-of-plane, concentrated impact (perpendicular to the plane of the laminated plate) using a drop weight with a hemispherical striker tip. The damage resistance is quantified in terms of the resulting size and type of damage in the specimen. The damage

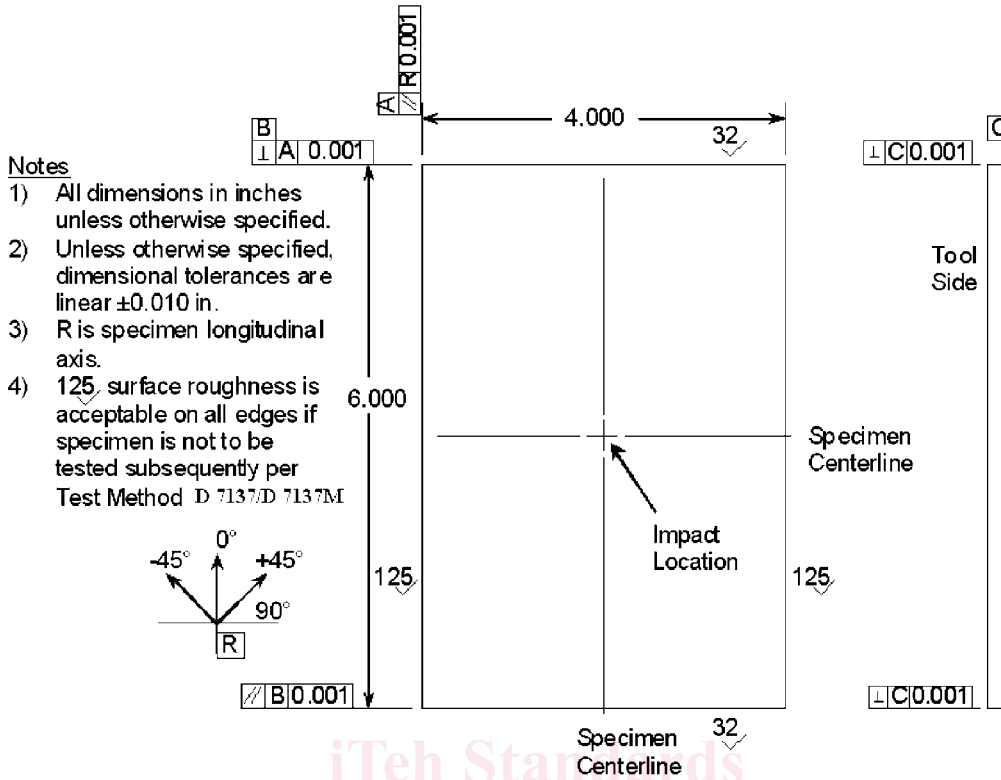

FIG. 7 Drop-Weight Impact Test Specimen (Inch-Pound Version)

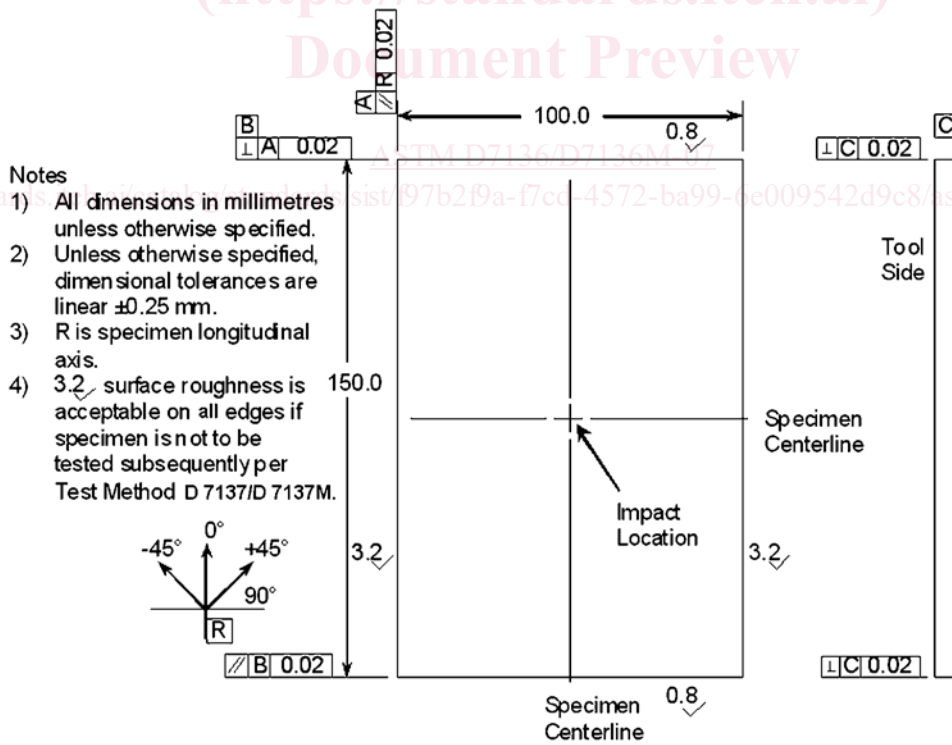

FIG. 8 Drop-Weight Impact Test Specimen (SI Version)

response is a function of the test configuration; comparisons cannot be made between materials unless identical test configurations, test conditions, and so forth are used.

4.2 Optional procedures for recording impact velocity and applied contact force versus time history data are provided.