



**SLOVENSKI STANDARD**  
**SIST ISO 16000-31:2015**  
**01-april-2015**

---

**Notranji zrak – 31. del: Meritve zaviralnikov plamena in plastifikatorji na osnovi organofosfornih spojin - Ester fosforjeve kisline**

Indoor air - Part 31: Measurement of flame retardants and plasticizers based on organophosphorus compounds - Phosphoric acid ester

**iTeh STANDARD PREVIEW**

Air intérieur - Partie 31: Mesurage des ignifugeants basés sur des composés organophosphorés - Ester d'acide phosphorique

[SIST ISO 16000-31:2015](https://standards.iteh.ai/catalog/standards/sist/d3f7edbb-1903-4b1f-9e6a-c86ac07ab0ae/sist-iso-16000-31-2015)

**Ta slovenski standard je istoveten z: ISO 16000-31:2014**

---

**ICS:**

13.040.20      Kakovost okoljskega zraka      Ambient atmospheres

**SIST ISO 16000-31:2015**

**en,fr**

**iTeh STANDARD PREVIEW**  
**(standards.iteh.ai)**

[SIST ISO 16000-31:2015](https://standards.iteh.ai/catalog/standards/sist/d3f7edbb-1903-4b1f-9e6a-c86ac67ab0ae/sist-iso-16000-31-2015)

<https://standards.iteh.ai/catalog/standards/sist/d3f7edbb-1903-4b1f-9e6a-c86ac67ab0ae/sist-iso-16000-31-2015>

---

---

**Indoor air —**

**Part 31:**

**Measurement of flame retardants  
and plasticizers based on  
organophosphorus compounds —  
Phosphoric acid ester**

iTeh STANDARD PREVIEW  
(standards.iteh.ai)

*Air intérieur —*

*Partie 31: Mesurage des ignifugeants basés sur des composés  
organophosphorés — Ester d'acide phosphorique*

<https://standards.iteh.ai/catalog/standards/sist/d3f7edbb-1903-4b1f-9e6a-c86ac67ab0ae/sist-iso-16000-31-2015>



## iTeh STANDARD PREVIEW (standards.iteh.ai)

SIST ISO 16000-31:2015

<https://standards.iteh.ai/catalog/standards/sist/d3f7edbb-1903-4b1f-9e6a-c86ac67ab0ae/sist-iso-16000-31-2015>



### **COPYRIGHT PROTECTED DOCUMENT**

© ISO 2014

All rights reserved. Unless otherwise specified, no part of this publication may be reproduced or utilized otherwise in any form or by any means, electronic or mechanical, including photocopying, or posting on the internet or an intranet, without prior written permission. Permission can be requested from either ISO at the address below or ISO's member body in the country of the requester.

ISO copyright office  
Case postale 56 • CH-1211 Geneva 20  
Tel. + 41 22 749 01 11  
Fax + 41 22 749 09 47  
E-mail [copyright@iso.org](mailto:copyright@iso.org)  
Web [www.iso.org](http://www.iso.org)

Published in Switzerland

# Contents

Page

<b>Foreword</b> .....	<b>iv</b>
<b>Introduction</b> .....	<b>vi</b>
<b>1 Scope</b> .....	<b>1</b>
<b>2 Normative references</b> .....	<b>1</b>
<b>3 Occurrence</b> .....	<b>1</b>
<b>4 Indoor air</b> .....	<b>3</b>
4.1 Measurement planning.....	3
4.2 Apparatus and materials for sampling and sample preparation.....	3
4.3 Sampling.....	6
4.4 Sample preparation.....	6
<b>5 Test chamber air</b> .....	<b>6</b>
5.1 General.....	6
5.2 Apparatus and materials for sampling.....	7
5.3 Sampling.....	7
5.4 Sampling procedure.....	8
5.5 Sample preparation.....	8
<b>6 Calibration</b> .....	<b>8</b>
6.1 Internal standard solutions and calibration solutions.....	8
6.2 Internal standard solutions.....	8
6.3 Calibration solutions for low resolution.....	9
6.4 Calibration solutions for high resolution.....	10
<b>7 Identification and quantification</b> .....	<b>11</b>
7.1 General.....	11
7.2 Analysis apparatus.....	11
7.3 Analysis with GC/ER-MS.....	11
7.4 Analysis with GC/HR-MS.....	11
7.5 Calculation result interpretation and presentation.....	13
<b>8 Performance characteristics</b> .....	<b>14</b>
8.1 Performance characteristics of the air analyses.....	14
<b>9 Quality assurance</b> .....	<b>14</b>
<b>10 Interferences</b> .....	<b>14</b>
<b>Annex A (informative) Nomenclature and physical characteristics</b> .....	<b>16</b>
<b>Annex B (informative) Example chromatograms for standard solutions</b> .....	<b>19</b>
<b>Bibliography</b> .....	<b>21</b>

## ISO 16000-31:2014(E)

## Foreword

ISO (the International Organization for Standardization) is a worldwide federation of national standards bodies (ISO member bodies). The work of preparing International Standards is normally carried out through ISO technical committees. Each member body interested in a subject for which a technical committee has been established has the right to be represented on that committee. International organizations, governmental and non-governmental, in liaison with ISO, also take part in the work. ISO collaborates closely with the International Electrotechnical Commission (IEC) on all matters of electrotechnical standardization.

The procedures used to develop this document and those intended for its further maintenance are described in the ISO/IEC Directives, Part 1. In particular the different approval criteria needed for the different types of ISO documents should be noted. This document was drafted in accordance with the editorial rules of the ISO/IEC Directives, Part 2 (see [www.iso.org/directives](http://www.iso.org/directives)).

Attention is drawn to the possibility that some of the elements of this document may be the subject of patent rights. ISO shall not be held responsible for identifying any or all such patent rights. Details of any patent rights identified during the development of the document will be in the Introduction and/or on the ISO list of patent declarations received (see [www.iso.org/patents](http://www.iso.org/patents)).

Any trade name used in this document is information given for the convenience of users and does not constitute an endorsement.

For an explanation on the meaning of ISO specific terms and expressions related to conformity assessment, as well as information about ISO's adherence to the WTO principles in the Technical Barriers to Trade (TBT) see the following URL: Foreword - Supplementary information

The committee responsible for this document is ISO/TC 146, *Air quality*, Subcommittee SC 6, *Indoor air*.

ISO 16000 consists of the following parts, under the general title *Indoor air*:

- *Part 1: General aspects of sampling strategy*
- *Part 2: Sampling strategy for formaldehyde*
- *Part 3: Determination of formaldehyde and other carbonyl compounds in indoor air and test chamber air — Active sampling method*
- *Part 4: Determination of formaldehyde — Diffusive sampling method*
- *Part 5: Sampling strategy for volatile organic compounds (VOCs)*
- *Part 6: Determination of volatile organic compounds in indoor and test chamber air by active sampling on Tenax TA® sorbent, thermal desorption and gas chromatography using MS or MS-FID*
- *Part 7: Sampling strategy for determination of airborne asbestos fibre concentrations*
- *Part 8: Determination of local mean ages of air in buildings for characterizing ventilation conditions*
- *Part 9: Determination of the emission of volatile organic compounds from building products and furnishing — Emission test chamber method*
- *Part 10: Determination of the emission of volatile organic compounds from building products and furnishing — Emission test cell method*
- *Part 11: Determination of the emission of volatile organic compounds from building products and furnishing — Sampling, storage of samples and preparation of test specimens*
- *Part 12: Sampling strategy for polychlorinated biphenyls (PCBs), polychlorinated dibenzo-p-dioxins (PCDDs), polychlorinated dibenzofurans (PCDFs) and polycyclic aromatic hydrocarbons (PAHs)*

- Part 13: Determination of total (gas and particle-phase) polychlorinated dioxin-like biphenyls (PCBs) and polychlorinated dibenzo-p-dioxins/dibenzofurans (PCDDs/PCDFs) — Collection on sorbent-backed filters
- Part 14: Determination of total (gas and particle-phase) polychlorinated dioxin-like biphenyls (PCBs) and polychlorinated dibenzo-p-dioxins/dibenzofurans (PCDDs/PCDFs) — Extraction, clean-up and analysis by high-resolution gas chromatography and mass spectrometry
- Part 15: Sampling strategy for nitrogen dioxide (NO<sub>2</sub>)
- Part 16: Detection and enumeration of moulds — Sampling by filtration
- Part 17: Detection and enumeration of moulds — Culture-based method
- Part 18: Detection and enumeration of moulds — Sampling by impaction
- Part 19: Sampling strategy for moulds
- Part 21: Detection and enumeration of moulds — Sampling from materials
- Part 23: Performance test for evaluating the reduction of formaldehyde concentrations by sorptive building materials
- Part 24: Performance test for evaluating the reduction of volatile organic compound (except formaldehyde) concentrations by sorptive building materials
- Part 25: Determination of the emission of semi-volatile organic compounds by building products — Micro-chamber method
- Part 26: Sampling strategy for carbon dioxide (CO<sub>2</sub>)
- Part 28: Determination of odour emissions from building products using test chambers
- Part 29: Test methods for VOC detectors
- Part 30: Sensory testing of indoor air
- Part 31: Measurement of flame retardants and plasticizers based on organophosphorus compounds — Phosphoric acid ester
- Part 32: Investigation of buildings for pollutants and other injurious factors — Inspections

The following parts are under preparation:

- Part 33: Determination of phthalates with gas chromatography/mass spectrometry (GC/MS)
- Part 34: Strategies for the measurement of airborne particles (PM<sub>2,5</sub> fraction)
- Part 35: Measurement of polybrominated diphenylether, hexabromocyclododecane and hexabromobenzene
- Part 36: Test method for the reduction rate of airborne bacteria by air purifiers using a test chamber

## ISO 16000-31:2014(E)

## Introduction

In general terms, phosphoric acid esters are formed by the reaction of alcohols or phenols with phosphoryl chloride ( $\text{POCl}_3$ ). A distinction is made between mono-, di-, and triesters (see [Figure 1](#)). The triesters with aryl and alkyl groups, as well as with mixed halogenated and halogen-free ester groups serve as plasticizers and flame retardants in plastics and varnishes. Parallel therewith, phosphoric acid esters are incorporated in hardeners and accelerants, in mordant and adhesion boosting agents, and serve as cleaning, corrosion inhibition, and adhesion-facilitating substances by the treatment of metal surfaces. They are used as auxiliary means in paper and textiles, as wetting and defoaming agents, emulsifiers, and stabilizers, as additives to cleaning agents and detergents, as not readily flammable hydraulic liquids, and as oil and fuel additives (see [Table 1](#)). Not considered in this regard are the groups of the thio- and dithiophosphoric acid esters (pesticides), as well as the phosphoric acid esters with cyanide and halogen groups, with a special impact as acetylcholinesterase inhibitors (nerve gases).<sup>[3]</sup>

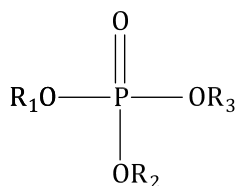

## Key

R aryl, alkyl, halogenated, and halogen-free ester groups

**Figure 1** — Structural formula of the phosphoric acid esters

(standards.iteh.ai)

Such multiplex applicability of the organophosphorus compounds (OPCs) leads to the effect that large indoor areas with OPC-containing building materials, varnishes, paints, floor care products, or fire protection coatings can be encountered. Due to their varying physical and physical-chemical properties, OPC can also be detected in the indoor transfer media (dust and air). As a rule, OPCs boiling at high temperatures such as tris(2-butoxyethyl) phosphate (TBEP, see [Annex A](#)) can be found in relevant concentrations in indoor air only if the emission source reaches elevated temperatures. In the case of such sources (e.g. screens or roller blinds for sun protection), the importance of higher temperatures must be taken into consideration when emission chamber tests are carried out.

There is an increasing public interest in the possible health effects of OPCs indoors. For indoor air, a Guideline Value II of  $0,05 \text{ mg/m}^3$  was published for TCEP and, in simplified terms, for the sum of TCEP, TCPP, TBP, TBEP, TEHP, and TPP as well. The Guideline Value I derived there amounts to  $0,005 \text{ mg/m}^3$ .<sup>[4]</sup> A review article on the occurrence and evaluation of OPC in an indoor environment is available.<sup>[5]</sup>

This part of ISO 16000 is based on VDI 4301 Part 5.



## Indoor air —

### Part 31:

# Measurement of flame retardants and plasticizers based on organophosphorus compounds — Phosphoric acid ester

## 1 Scope

This part of ISO 16000 specifies a test method for the sampling and analysis of the phosphoric acid esters in indoor air and in test chamber air through gas chromatography/mass spectrometry. Both principle methods of the low-resolution mass spectrometry and the high-resolution mass spectrometry are described.

The methods described in this part of ISO 16000 are not suitable for the determination of the phosphoric acid esters in materials.

NOTE ISO 16000-6 can be applied for the determination of the more volatile compounds covered by this standard.

## iTeh STANDARD PREVIEW

## 2 Normative references

(standards.iteh.ai)

The following documents, in whole or in part, are normatively referenced in this document and are indispensable for its application. For dated references, only the edition cited applies. For undated references, the latest edition of the referenced document (including any amendments) applies.

ISO 16000-1, *Indoor air — Part 1: General aspects of sampling strategy*

ISO 16000-9, *Indoor air — Part 9: Determination of the emission of volatile organic compounds from building products and furnishing — Emission test chamber method*

ISO 16000-13, *Indoor air — Part 13: Determination of total (gas and particle-phase) polychlorinated dioxin-like biphenyls (PCBs) and polychlorinated dibenzo-p-dioxins/dibenzofurans (PCDDs/PCDFs) — Collection on sorbent-backed filters*

## 3 Occurrence

The following compounds belonging to the halogen-free organophosphates are frequently detected in indoor air:

- triphenyl phosphate (TPP);
- tris(2-butoxyethyl) phosphate (TBEP);
- tri-n-butyl phosphate (TBP);
- tris(2-ethylhexyl) phosphate (TEHP);
- cresyl diphenyl phosphate (CDP);
- triethyl phosphate (TEP);
- tricresyl phosphate (TCP).

## ISO 16000-31:2014(E)

The following halogenated phosphoric acid esters are detected predominantly in house dust and indoor air:

- tris(2-chloroethyl) phosphate (TCEP);
- tris(chloropropyl) phosphate (TCPP);
- tris(1,3-dichloro-2-propyl) phosphate (TDCPP).

Bridged diphosphates based on resorcinol- and bisphenol-A are also increasingly implemented as flame retardants, e. g.

- tetraphenyl resorcinol diphosphate (RDP) or
- tetraphenyl bisphenol-A diphosphate (BDP).

So far, there is little information about the release of these compounds from primary sources.

[Table 1](#) provides an overview of the organophosphates frequently detected in indoor air. The nomenclature and the chemical and physical data on the organophosphates are listed in [Annex A](#).

**Table 1 — Organophosphates and their intended use (see References[5] and[6])**

OPC Abbreviation	Organophosphates	Intended use as flame retardant and plasticizer
CDP	Cresyl diphenyl phosphate	Flame retardant coatings
RDP	Tetraphenyl resorcinol diphosphate	Casing materials, special cables
TBEP	Tris(2-butoxyethyl) phosphate	Floor care products, floor wax, additives in elastomers, solvents for resins, antifoaming agents, additives for plastic, synthetic rubber, and varnishes
TBP	Tri-n-butyl phosphate	Defoaming agents for concrete additives, wall paper, dispersion paints, varnishes, rubber, plastic, and vinyl resins, antifoaming agents
TCEP	Tris(2-chloroethyl) phosphate	Paints, coatings, soundproofing ceilings, fibre glass wall paper, expanding foam, casing materials
TCPP	Tris(1-chloro-2-propyl)-phosphate <sup>a</sup>	Sound-absorbing polyurethane foam, expansion foam, soft foam (seats, mattresses), rear lining of textile, casing materials
TDBPP	Tris(2,3-dibromopropyl) phosphate	Foamed rubber, varnishes, paper, paints, cellulose-, triacetate-, and polyester fabrics, carpets, resins, furniture, car interior details
TDCPP	Tris(1,3-dichloro-2-propyl) phosphate	PU foam, casing materials, rear lining of textile
TEHP	Tris(2-ethylhexyl) phosphate	Stabilizers, fat additives, additives for synthetic rubber
TCP	Tricresyl phosphate	Lubricants, car interiors, additives to floor covering and wall cladding
TPP	Triphenyl phosphate	Expanding foam, paints and varnishes, brighteners, casing materials, photographic films, phenol resins, additives for lubricants, car interior details

<sup>a</sup> Technical TCPP does not exist as a pure isomer. Hence it usually leads to up to three GC signals.

The published concentrations of indoor air measurements are compiled in [Table 2](#). Citing of occasion-relevant measurement values cannot be excluded.

**Table 2 — Published results on OPC in indoor air**

Substance	Concentration in indoor air $\mu\text{g}/\text{m}^3$		
	Range	Median	Reference
TCEP	< 0,005 to 6	0,10 to 0,38	[8][9][10]
TCPP	0,019 to 0,058	–	[10]
TBP	0,01 to 0,064	–	[10]
TBEP	0,001 to 0,03	–	[9] and [10]
TEHP	< 0,001 to 0,01	–	[10]
TPP	< 0,01	–	[9] and [10]
TCP	< 0,01	–	[9]

## 4 Indoor air

### 4.1 Measurement planning

The measurement planning for the determination of the indoor air for phosphoric acid esters is performed according to the requirements of ISO 16000-1.

### 4.2 Apparatus and materials for sampling and sample preparation

#### 4.2.1 Sampling apparatus

The sampling system is described in detail in ISO 16000-13.

**4.2.1.1 Sampling head**, with a sleeve for holding the PU foams ([Figures 2a](#) and [2b](#)) (see also ISO 16000-13).

## ISO 16000-31:2014(E)

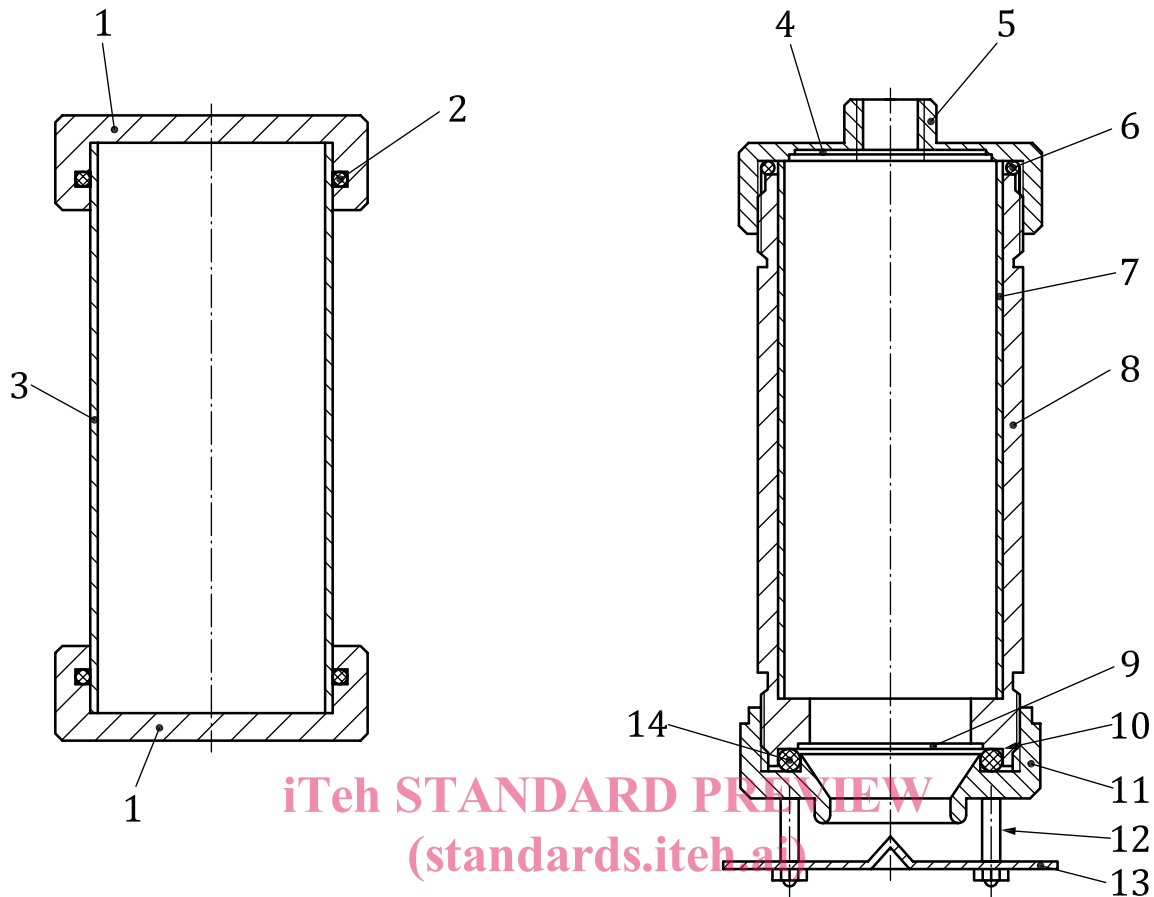

a) PU foam sleeve with cover (aluminium)      b) Sampling head

## Key

- 1 cover
- 2 O-ring
- 3 PU foam sleeve (external diameter: 49,5 mm, length: approx. 120 mm)
- 4 stainless steel mesh
- 5 cap
- 6 O-ring
- 7 PU foam sleeve
- 8 cylinder (internal diameter: 49,8 mm)
- 9 stainless steel mesh to carry the glass fibre filter
- 10 PTFE-ring/filter disc/PTFE-ring
- 11 cap with inlet bore (internal diameter of the inlet bore: 27 mm)
- 12 spacer
- 13 baffle plate
- 14 O-ring

Figure 2 — Sampling apparatus consisting of a sampling head with a sleeve for holding PU foams

4.2.1.2 **Pump**, with volumetric flow of 2,7 m<sup>3</sup>/h to 2,8 m<sup>3</sup>/h (45 l/min to 46,7 l/min) under sampling conditions.