



**SLOVENSKI STANDARD**  
**SIST EN 933-4:2000**  
**01-september-2000**

---

DfYg\_i gj[ Yca Yf] b] \ `Ug]bcgh]U[ fY[ Urcj `!( "XY. `8c`c Yj Ub^cV]\_Ynfb`!`AcXi `cV]\_Y

Tests for geometrical properties of aggregates - Part 4: Determination of particle shape - Shape index

Prüfverfahren für geometrische Eigenschaften von Gesteinskörnungen - Teil 4: Bestimmung der Kornform - Kornformkennzahl

Essais pour déterminer les caractéristiques géométriques des granulats - Partie 4: Détermination de la forme des grains - Indice de forme

<https://standards.iteh.ai/catalog/standards/sist/8bbc70b1-bf09-42eb-a949-dfd5903800fe/sist-en-933-4-2000>

**Ta slovenski standard je istoveten z: EN 933-4:1999**

---

**ICS:**

91.100.15      Mineralni materiali in izdelki      Mineral materials and products

**SIST EN 933-4:2000**

**en**

**iTeh STANDARD PREVIEW**  
**(standards.iteh.ai)**

SIST EN 933-4:2000

<https://standards.iteh.ai/catalog/standards/sist/8bbc70b1-bf09-42eb-a949-dfd5903800fe/sist-en-933-4-2000>

ICS 91.100.15; 91.100.20

English version

## Tests for geometrical properties of aggregates - Part 4: Determination of particle shape - Shape index

Essais pour déterminer les caractéristiques géométriques  
des granulats - Partie 4: Détermination de la forme des  
grains - Indice de forme

Prüfverfahren für geometrische Eigenschaften von  
Gesteinskörnungen - Teil 4: Bestimmung der Kornform -  
Kornformkennzahl

This European Standard was approved by CEN on 3 September 1999.

CEN members are bound to comply with the CEN/CENELEC Internal Regulations which stipulate the conditions for giving this European Standard the status of a national standard without any alteration. Up-to-date lists and bibliographical references concerning such national standards may be obtained on application to the Central Secretariat or to any CEN member.

This European Standard exists in three official versions (English, French, German). A version in any other language made by translation under the responsibility of a CEN member into its own language and notified to the Central Secretariat has the same status as the official versions.

CEN members are the national standards bodies of Austria, Belgium, Czech Republic, Denmark, Finland, France, Germany, Greece, Iceland, Ireland, Italy, Luxembourg, Netherlands, Norway, Portugal, Spain, Sweden, Switzerland and United Kingdom.

iTeh STANDARD PREVIEW  
(standards.iteh.ai)

SIST EN 933-4:2000

<https://standards.iteh.ai/catalog/standards/sist/8b6c7051-bf09-42eb-a949-dfd5903800fe/iso-en-933-4-2000>

EUROPEAN COMMITTEE FOR STANDARDIZATION  
COMITÉ EUROPÉEN DE NORMALISATION  
EUROPÄISCHES KOMITEE FÜR NORMUNG

Central Secretariat: rue de Stassart, 36 B-1050 Brussels

## Contents

	Page
Foreword	3
1 Scope	4
2 Normative references	4
3 Definitions	4
4 Principle	5
5 Apparatus	5
6 Preparation of test portion	6
7 Procedure	6
8 Calculation and expression of results	8
9 Test report	9
Annex A (informative) Example of a test data sheet used for determining the shape index of coarse aggregate	10

## iTeh STANDARD PREVIEW (standards.iteh.ai)

SIST EN 933-4:2000

<https://standards.iteh.ai/catalog/standards/sist/8bbc70b1-bf09-42eb-a949-dfd5903800fe/sist-en-933-4-2000>



## Foreword

This European Standard has been prepared by Technical Committee CEN/TC 154 "Aggregates", the secretariat of which is held by BSI.

This European Standard shall be given the status of a national standard, either by publication of an identical text or by endorsement, at the latest by April 2000, and conflicting national standards shall be withdrawn at the latest by December 2003.

According to the CEN/CENELEC Internal Regulations, the national standards organizations of the following countries are bound to implement this European Standard: Austria, Belgium, Czech Republic, Denmark, Finland, France, Germany, Greece, Iceland, Ireland, Italy, Luxembourg, Netherlands, Norway, Portugal, Spain, Sweden, Switzerland and the United Kingdom

This European Standard is one of a series of standards for tests for geometrical properties of aggregates. Test methods for other properties of aggregates are covered by Parts of the following European Standards:

EN 932	Tests for general properties of aggregates
EN 1097	Tests for mechanical and physical properties of aggregates
EN 1367	Tests for thermal and weathering properties of aggregates
EN 1744	Tests for chemical properties of aggregates
prEN 13179	Tests for filler aggregate used in bituminous mixtures

The other parts of EN 933 will be:

Part 1	Determination of particle size distribution - Sieving method
Part 2	Determination of particle size distribution - Test sieves, nominal size of apertures
Part 3	Determination of particle shape - Flakiness index
Part 5	Determination of percentage of crushed and broken surfaces in coarse aggregate particles
Part 6	Determination of particle shape - Flakiness index
Part 7	Determination of shell content - Percentage of shells for coarse aggregates
Part 8	Assessment of fines - Sand equivalent test
Part 9	Assessment of fines - Methylene blue test
Part 10	Assessment of fines - Grading of fillers (air jet sieving)

## iTeh STANDARD PREVIEW (standards.iteh.ai)

[SIST EN 933-4:2000](https://standards.iteh.ai/catalog/standards/sist/8bbc70b1-bf09-42eb-a949-dfd5903800fe/sist-en-933-4-2000)

<https://standards.iteh.ai/catalog/standards/sist/8bbc70b1-bf09-42eb-a949-dfd5903800fe/sist-en-933-4-2000>

## 1 Scope

This European standard specifies a method for the determination of the shape index of coarse aggregates. It applies to aggregates of natural or artificial origin, including lightweight aggregates.

The test method specified in this European Standard is applicable to particle size fractions  $d/D_i$  where  $D_i \leq 63$  mm and  $d \geq 4$  mm.

## 2 Normative references

This European standard incorporates by dated or undated reference, provisions from other publications. The normative references are cited at the appropriate places in the text and the publications are listed hereafter. For dated references, subsequent amendments to or revisions of any of these publications apply to this European Standard only when incorporated in it by amendment or revision. For undated references, the latest edition of the publication referred to applies.

EN 932-2	Test for general properties of aggregates - Part 2: Methods for reducing laboratory samples
prEN 932-5	Tests for general properties of aggregates - Part 5: Common equipment and calibration
EN 933-1	Tests for geometrical properties of aggregates - Part 1: Determination of particle size distribution - Sieving method
EN 933-2	Tests for geometrical properties of aggregates - Part 2: Determination of particle size distribution - Test sieves, nominal size of apertures
prEN 1097-6	Tests for mechanical and physical properties of aggregates - Part 6: Determination of the particle density and water absorption

## 3 Definitions

For the purposes of this standard, the following definitions apply:

**3.1 aggregate size:** Designation of aggregate in terms of lower ( $d$ ) and upper ( $D$ ) sieve sizes, expressed as  $dD$ .

NOTE: This designation accepts the presence of some particles which will be retained on the upper sieve (oversize) and some which will pass the lower sieve (undersize).

**3.2 particle size fraction  $d/D_i$ :** Fraction of an aggregate passing the larger ( $D_i$ ) of two sieves and retained on the smaller ( $d$ ).

**3.3 test portion:** Sample used as a whole in a single test.

**3.4 constant mass:** Successive weighings after drying at least 1 h apart not differing by more than 0,1 %.

NOTE: In many cases constant mass can be achieved after a test portion has been dried for a pre-determined period in a specified oven (see 5.5) at  $(110 \pm 5)$  °C. Test laboratories can determine the time required to achieve constant mass for specific types and sizes of sample dependent upon the drying capacity of the oven used.

**3.5 particle length  $L$ :** Maximum dimension of a particle as defined by the greatest distance apart of two parallel planes tangential to the particle surface.

**3.6 particle thickness  $E$ :** Minimum dimension of a particle as defined by the least distance apart of two parallel planes tangential to the particle surface.

## 4 Principle

Individual particles in a sample of coarse aggregate are classified on the basis of the ratio of their length  $L$  to thickness  $E$  using a particle slide gauge where necessary.

The shape index is calculated as the mass of particles with a ratio of dimensions  $L/E$  more than 3 expressed as a percentage of the total dry mass of particles tested.

## 5 Apparatus

**5.1 All apparatus,** unless otherwise stated, shall conform to the general requirements of prEN 932-5.

**5.2 Particle slide gauge,** an example of which is shown in figure 1.

**5.3 Test sieves,** with nominal size of apertures as specified in EN 933-2.

**5.4 Tightly fitting pan and lid,** for the sieves.

**5.5 Ventilated oven,** thermostatically controlled to maintain a temperature of  $(110 \pm 5) ^\circ\text{C}$ , or other suitable equipment for drying the aggregates, if it does not cause any particle size breakdown.

**5.6 Balances or scales,** of suitable capacity, readable to 0,1 % of the mass to be weighed.

**5.7 Trays.**

**5.8 Sieving machine,** (optional).

Dimensions in millimetres

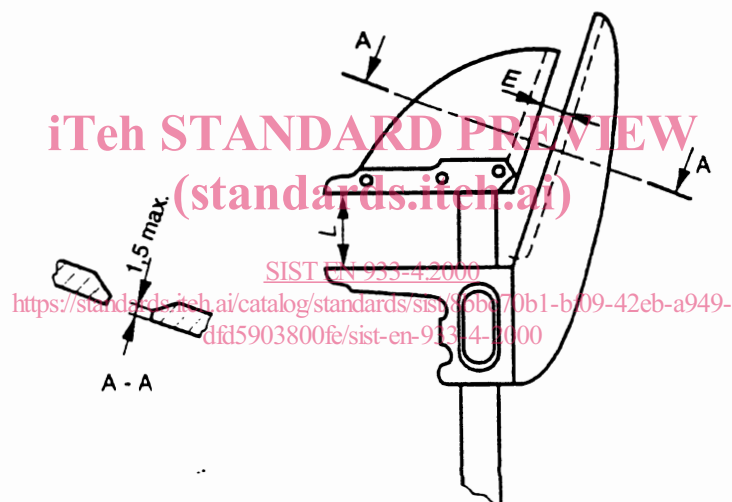

Figure 1: Example of a particle slide gauge

## 6 Preparation of test portion

The sample shall be reduced in accordance with the requirements of EN 932-2

Dry the sample at  $(110 \pm 5)$  °C to constant mass.

Sieve on appropriate test sieves with sufficient vigour to ensure complete separation of particles greater than 4 mm. Discard the particles retained on the 63 mm test sieve and those passing the 4 mm test sieve.

If necessary further reduce the sample in accordance with EN 932-2 to produce a test portion. Record the mass of the test portion as  $M_0$ .

The mass of the test portion shall be as specified in table 1.

**Table 1: Mass of test portions**

Upper aggregate size $D$ mm	Test portion mass (minimum) kg
63	45
32	6
16	1
8	0,1

NOTE 1: For the other upper aggregate sizes  $D$ , appropriate test portion masses may be interpolated from those given in table 1.

NOTE 2: For aggregates of particle density less than  $2,00 \text{ Mg/m}^3$  or more than  $3,00 \text{ Mg/m}^3$  in accordance with prEN 1097-6 an appropriate correction should be applied to the test portion masses given in table 1 based on the density ratio, in order to produce a test portion of approximately the same volume as those for aggregates of normal density.

Sample reduction shall yield a test portion of mass larger than the minimum but not of an exact predetermined value.

**iTeh STANDARD PREVIEW**  
(standards.iteh.ai)

## 7 Procedure

### 7.1 General

SIST EN 933-4:2000

<https://standards.iteh.ai/catalog/standards/sist/8bbc70b1-bf09-42eb-a949-8a59b800431e/en-933-4:2000>

The test shall be carried out on each particle size fraction  $d/D_1$  where  $D_1 \leq 2d$ .

Test portions from samples for which  $D > 2d$  shall be separated into particle size fractions  $d/D_1$  where  $D_1 \leq 2d$  during the subsequent test procedure.

### 7.2 Test portions where $D \leq 2d$

Separate the predominant particle size fraction  $d/D_1$  where  $D_1 \leq 2d$  from the test portion by sieving in accordance with EN 933-1.



NOTE 1: Test sieves of appropriate aperture sizes from the following series should be used, viz. 4 mm; 5,6 mm; 8 mm; 11,2 mm; 16 mm; 22,4 mm; 31,5 mm; 45 mm; 63 mm; and the values of  $d$  and  $D$  of the size fraction tested should be recorded in the test report.

Discard any particles smaller than  $d$  or larger than  $D$ .

Record the mass of the predominant particle size fraction  $d/D$  as  $M_1$ .

Assess the length  $L$  and thickness  $E$  of each particle using a particle slide gauge where necessary and set aside those particles which have a dimensional ratio  $L/E > 3$ . These particles are classified as non-cubical.

NOTE 2: The number of particles requiring individual classification using the gauge can be reduced by a preliminary separation of particles with  $L/E$  ratio significantly different from 3.

Weigh the non-cubical particles and record their mass as  $M_2$ .

### 7.3 Test portion where $D > 2d$

Separate the test portion into particle size fractions  $d/D$  where  $D \leq 2d$  by sieving in accordance with EN 933-1.

NOTE 1: Test sieves of appropriate aperture sizes from the following series should be used, viz. 4 mm; 5,6 mm; 8 mm; 11,2 mm; 16 mm; 22,4 mm; 31,5 mm; 45 mm; 63 mm; and the values of  $d$  and  $D$  of each size fraction tested should be recorded in the test report.

Record the mass of each particle size fraction ( $M_i$ ) and calculate and record the percentage by mass of each particle size fraction  $d/D$  to the test portion mass  $M_0$  as  $V_i$ .

Discard any size fraction  $d/D$  which comprises less than 10 % of  $M_0$ .

NOTE 2: If any remaining size fraction  $d/D$  contains less than 100 particles, it should if required, be recorded in the test report.

Any size fraction  $d/D$  which contains an excessive number of particles can be further reduced in accordance with EN 932-2, but after such reduction at least 100 particles of that size fraction shall remain.

Record the mass of particles to be tested in each remaining particle size fraction  $d/D$  as  $M_{1i}$ .

Assess the length  $L$  and thickness  $E$  of each particle using a particle slide gauge where necessary and set aside those particles in each size fraction which have a dimensional ratio  $L/E > 3$ . These particles are classified as non-cubical.

Record the mass of non-cubical particles in each of these size fractions  $d/D$  as  $M_{2i}$ .

<https://standards.iteh.ai/catalog/standards/sist/8bbc70b1-bf09-42eb-a949-dfd5903800fe/sist-en-933-4-2000>