**Thermal insulating products for
building applications — Determination
of shear behaviour**

*Produits isolants thermiques destinés aux applications du bâtiment —
Détermination du comportement en cisaillement*

iTeh STANDARD PREVIEW
(standards.iteh.ai)

[ISO 16537:2012](https://standards.iteh.ai/catalog/standards/sist/dd2f99d1-56c4-4cbc-a4c9-e2e269a59a97/iso-16537-2012)

[https://standards.iteh.ai/catalog/standards/sist/dd2f99d1-56c4-4cbc-a4c9-
e2e269a59a97/iso-16537-2012](https://standards.iteh.ai/catalog/standards/sist/dd2f99d1-56c4-4cbc-a4c9-e2e269a59a97/iso-16537-2012)



iTeh STANDARD PREVIEW
(standards.iteh.ai)

ISO 16537:2012

<https://standards.iteh.ai/catalog/standards/sist/dd2f99d1-56c4-4cbc-a4c9-e2e269a59a97/iso-16537-2012>



COPYRIGHT PROTECTED DOCUMENT

© ISO 2012

All rights reserved. Unless otherwise specified, no part of this publication may be reproduced or utilized in any form or by any means, electronic or mechanical, including photocopying and microfilm, without permission in writing from either ISO at the address below or ISO's member body in the country of the requester.

ISO copyright office
Case postale 56 • CH-1211 Geneva 20
Tel. + 41 22 749 01 11
Fax + 41 22 749 09 47
E-mail copyright@iso.org
Web www.iso.org

Published in Switzerland

Contents	Page
Foreword	iv
Introduction	v
1 Scope	1
2 Normative references	1
3 Terms and definitions	1
4 Principle	1
5 Apparatus	2
5.1 Test machine	2
5.2 Specimen supports	2
5.3 Adhesive	3
6 Test specimens	5
6.1 Dimensions of test specimens	5
6.2 Number of test specimens	6
6.3 Preparation of test specimens	6
6.4 Conditioning of test specimens	6
7 Procedure	6
7.1 Test conditions	6
7.2 Test procedure	6
8 Calculation and expression of results	7
8.1 General	7
8.2 Shear strength	7
8.3 Shear modulus	7
9 Accuracy of measurement	8
10 Test report	8

Foreword

ISO (the International Organization for Standardization) is a worldwide federation of national standards bodies (ISO member bodies). The work of preparing International Standards is normally carried out through ISO technical committees. Each member body interested in a subject for which a technical committee has been established has the right to be represented on that committee. International organizations, governmental and non-governmental, in liaison with ISO, also take part in the work. ISO collaborates closely with the International Electrotechnical Commission (IEC) on all matters of electrotechnical standardization.

International Standards are drafted in accordance with the rules given in the ISO/IEC Directives, Part 2.

The main task of technical committees is to prepare International Standards. Draft International Standards adopted by the technical committees are circulated to the member bodies for voting. Publication as an International Standard requires approval by at least 75 % of the member bodies casting a vote.

Attention is drawn to the possibility that some of the elements of this document may be the subject of patent rights. ISO shall not be held responsible for identifying any or all such patent rights.

ISO 16537 was prepared by Technical Committee ISO/TC 163, *Thermal performance and energy use in the built environment*, Subcommittee SC 1, *Test and measurement methods*.

ISO 16537 includes the original EN 12090 prepared by Technical Committee CEN/TC 88 “Thermal insulating materials and products”, with the following clauses modified to reflect the conditions for tropical countries:

- Clause 6.4: Conditioning of test specimens;
- Clause 7.1: Test conditions; and
- Clause 10: Test report.

iTeh STANDARD PREVIEW
(standards.iteh.ai)
<https://standards.iteh.ai/catalog/standards/sist/dd2f99d1-56c4-4cbc-a4c9-e2e269a59a97/iso-16537-2012>

Introduction

ISO 16537 is one of a series of existing European Standards on test methods which were adopted by ISO. This group of International Standards comprises the following group of interrelated standards:

ISO	Title	Respective EN standard
12344	Thermal insulating products for building applications — Determination of bending behaviour	EN 12089
12968	Thermal insulation products for building applications — Determination of the pull-off resistance of external thermal insulation composite systems (ETICS) (foam block test)	EN 13495
29465	Thermal insulating products for building applications — Determination of length and width	EN 822
29466	Thermal insulating products for building applications — Determination of thickness	EN 823
29467	Thermal insulating products for building applications — Determination of squareness	EN 824
29468	Thermal insulating products for building applications — Determination of flatness	EN 825
29469	Thermal insulating products for building applications — Determination of compression behaviour	EN 826
29470	Thermal insulating products for building applications — Determination of the apparent density	EN 1602
29471	Thermal insulating products for building applications — Determination of dimensional stability under constant normal laboratory conditions (23 degrees C/50 % relative humidity)	EN 1603
29472	Thermal insulating products for building applications — Determination of dimensional stability under specified temperature and humidity conditions	EN 1604
29764	Thermal insulating products for building applications — Determination of deformation under specified compressive load and temperature conditions	EN 1605
29765	Thermal insulating products for building applications — Determination of tensile strength perpendicular to faces	EN 1607
29766	Thermal insulating products for building applications — Determination of tensile strength parallel to faces	EN 1608
29767	Thermal insulating products for building applications — Determination of short-term water absorption by partial immersion	EN 1609
29768	Thermal insulating products for building applications — Determination of linear dimensions of test specimens	EN 12085
29769	Thermal insulating products for building applications — Determination of behaviour under point load	EN 12430
29770	Thermal insulating products for building applications — Determination of thickness for floating-floor insulating products	EN 12431

ISO 16537:2012(E)

29771	Thermal insulating materials for building applications — Determination of organic content	EN 13820
29803	Thermal insulation products for building applications — Determination of the resistance to impact of external thermal insulation composite systems (ETICS)	EN 13497
29804	Thermal insulation products for building applications — Determination of the tensile bond strength of the adhesive and of the base coat to the thermal insulation material	EN 13494
29805	Thermal insulation products for building applications — Determination of the mechanical properties of glass fibre meshes	EN 13496
16534	Thermal insulating products for building applications — Determination of compressive creep	EN 1606
16535	Thermal insulating products for building applications — Determination of long-term water absorption by immersion	EN 12087
16536	Thermal insulating products for building applications — Determination of long-term water absorption by diffusion	EN 12088
16537	Thermal insulating products for building applications — Determination of shear behaviour	EN 12090
16546	Thermal insulating products for building applications — Determination of freeze-thaw resistance	EN 12091
16544	Thermal insulating products for building applications — Conditioning to moisture equilibrium under specified temperature and humidity conditions	EN 12429
16545	Thermal insulating products for building applications — Determination of behaviour under cyclic loading	EN 13793

A further group of existing European Standards on test methods for products used to insulate building equipment and industrial installations comprises the following group of interrelated International Standards:

ISO 12623	Thermal insulating products for building equipment and industrial installations — Determination of short-term water absorption by partial immersion of preformed pipe insulation	EN 13472
ISO 12624	Thermal insulating products for building equipment and industrial installations — Determination of trace quantities of water soluble chloride, fluoride, silicate, sodium ions and pH	EN 13468
ISO 12628	Thermal insulating products for building equipment and industrial installations — Determination of dimensions, squareness and linearity of preformed pipe insulation	EN 13467
ISO 12629	Thermal insulating products for building equipment and industrial installations — Determination of water vapour transmission properties of preformed pipe insulation	EN 13469

Thermal insulating products for building applications — Determination of shear behaviour

1 Scope

This International Standard specifies the equipment and procedures for determining shear behaviour. It is applicable to thermal insulating products.

NOTE The tests described in this International Standard do not determine pure shear behaviour, but measure the effects of applying two opposite parallel forces to the major faces of the test specimen. The test is, however, called “shear” in this text by convention. The application of a force tangentially to the major surface of the test specimen is considered to represent more closely the stresses imposed upon thermal insulation products in many building applications, particularly walls, than other methods of measuring shear performance, e.g. bending tests.

2 Normative references

The following referenced document is indispensable for the application of this document. For dated references, only the edition cited applies. For undated references, the latest edition of the referenced document (including any amendments) applies.

ISO 29768, *Thermal insulating products for building applications — Determination of linear dimensions of test specimens*

3 Terms and definitions

For the purposes of this document, the following definitions apply.

3.1

shear strength

τ

ratio of the maximum force applied to the product, which will cause rupture along a plane parallel to the direction of the applied force, to the area of the plane on which the force acts

3.2

shear modulus

G

shear stress divided by the corresponding relative deformation below the proportional limit, when the relationship is linear

NOTE See Figure 3.

4 Principle

A test specimen is subjected to a shear stress transmitted to the test specimen through rigid supports to which it is bonded. The corresponding force-displacement curve is determined.

NOTE Tests carried out using the single test specimen method have produced results for shear strength which indicate the result to be dependent upon test specimen thickness, with more scattered results at greater thicknesses. Tests using the double test specimen method have also shown test specimen thickness to influence results for shear strength.

5 Apparatus

5.1 Test machine

5.1.1 General

A test machine capable of applying a sufficient force within the maximum displacement experienced in the shear test. It shall be capable of operating at a constant rate of movement of the movable head of $(3 \pm 0,5)$ mm/min in a direction parallel to the longitudinal axis of the test specimen assembly.

The test machine shall exert a force F on the test specimen with a maximum error of 1 %, and produce a displacement, γ , of the movable support relative to the fixed supports, having a maximum error of 1 %.

If the shear modulus is required, the force F and the displacement γ shall be simultaneously recorded to provide the curve of F , γ required in Clause 7.

NOTE 1 It may be necessary to use a displacement transducer for accurate measurement of deformation, particularly where a thick adhesive layer has been used in preparing the test specimen.

The null or zero displacement of the test specimen may be calculated by subtraction from γ , the displacement due to the equipment and the same thickness of adhesive measured without the test specimen, e.g. by replacing the test specimen by metal block(s) in a blank test.

5.1.2 Single test specimen arrangement

The test machine shall exert longitudinal shear forces through parallel plates bonded to a single test specimen of dimensions as in 6.1.2. The parallel plates shall be rigid with one plate attached to the fixed part and the other to the movable parts of the test machine.

5.1.3 Double test specimen arrangement

ISO 16537:2012

<https://standards.iteh.ai/catalog/standards/sist/dd2f99d1-56c4-4cbc-a4c9-369c5b97/cor-16537-2012>

The test machine shall exert longitudinal shear forces through parallel plates bonded to a double test specimen of dimensions as in 6.1.3. The parallel plates shall be rigid with the outer plates attached to the fixed part and the central plate to the movable parts of the test machine.

5.2 Specimen supports

5.2.1 Single test specimen assembly

Two flat rigid specimen supports of length 330 mm and width 50 mm shall be attached to the grips of the test machine via an adaptor and universal joint. The method of attaching the specimen supports to the grips is shown in Figure 1. The thickness of the adaptors that connect the specimen supports to the test machine grips shall be the same as the thickness of the test specimen.

NOTE Flat rectangular sectioned mild steel plates with a thickness of 16 mm have proved suitable for the support material.

5.2.2 Double test specimen assembly

The essential features are three flat rigid supports of which two can be maintained with their planes parallel and vertical. Two suitable arrangements are shown in Figure 2.

Experience gained using both the single and double test specimen methods with several products has indicated that it is of paramount importance that the specimen supports be very rigid. With the double test specimen arrangement, the fixed supports should be maintained in parallel vertical planes. Both the arrangements shown in Figure 2 have proved suitable.

5.3 Adhesive

The adhesive used to fix the test specimen shall be such that the shear strength and modulus of the adhesive film is greater than that of the product under test. This ensures that rupture occurs in the test specimen rather than in the adhesive.

Information on suitable adhesives and their use may be provided in the relevant product standard or any other technical specification.

Dimensions in millimetres

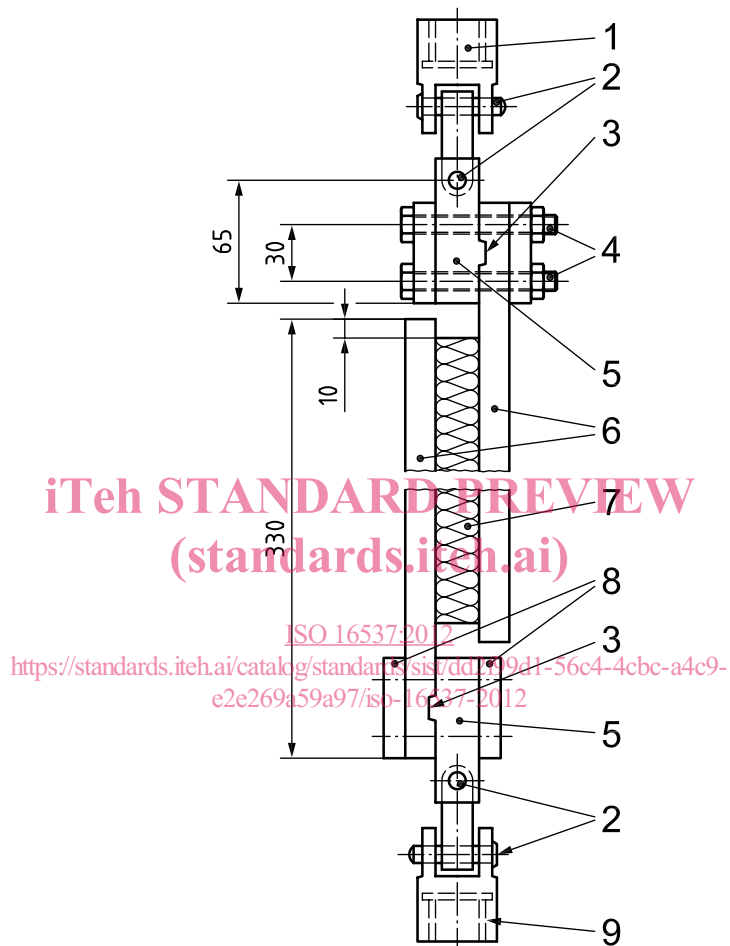

Key

- 1 fixed machine grip
- 2 universal joint connection pins
- 3 tongue and groove
- 4 nut and bolt supports
- 5 adaptor
- 6 test specimen supports (length 330 mm, width 50 mm, thickness 16 mm)
- 7 test specimen (length 250 mm, width 50 mm)
- 8 load distribution plates
- 9 movable machine grip

Figure 1 — Example of single specimen test assembly