



Designation: ~~D3511-05~~ Designation: D 3511 - 07

## Standard Test Method for Pilling Resistance and Other Related Surface Changes of Textile Fabrics: Brush Pilling Tester<sup>1</sup>

This standard is issued under the fixed designation D 3511; the number immediately following the designation indicates the year of original adoption or, in the case of revision, the year of last revision. A number in parentheses indicates the year of last reapproval. A superscript epsilon ( $\epsilon$ ) indicates an editorial change since the last revision or reapproval.

*This standard has been approved for use by agencies of the Department of Defense.*

### 1. Scope

1.1 This test method covers the determination of the propensity of a fabric to form pills from fuzz under test conditions intended to simulate normal wear using the brush pilling tester. This procedure is generally applicable to all types of apparel fabrics including both woven and knitted fabrics.

NOTE 1—For other test methods for the pilling resistance of textiles, refer to Test Methods D 3512, D 3514, and D 4970.

1.2 The values stated in either SI units or inch-pound units are to be regarded separately as the standard. Within the text, the inch-pound units are shown in parentheses. The values stated in each system are not exact equivalents; therefore, each system shall be used independently of the other. Combining values from the two systems may result in nonconformance with the specification.

1.3 *This standard does not purport to address all of the safety concerns, if any, associated with its use. It is the responsibility of the user of this standard to establish appropriate safety and health practices and determine the applicability of regulatory limitations prior to use.*

### 2. Referenced Documents

#### 2.1 ASTM Standards:<sup>2</sup>

D 123 Terminology Relating to Textiles

D 1776 Practice for Conditioning and Testing Textiles

D 3512 Test Method for Pilling Resistance and Other Related Surface Changes of Textile Fabrics: Random Tumble Pilling Tester

D 3514 Test Method for Pilling Resistance and Other Related Surface Changes of Textile Fabrics: Elastomeric Pad

D 4970 Test Method for Pilling Resistance and Other Related Surface Changes of Textile Fabrics (Martindale Pressure Fabrics: Martindale Tester Method)

#### 2.2 ASTM Adjuncts:<sup>3</sup>

~~ADJD3512 Set of 5 Photographic Standards for Random Tumble Pilling Test~~ ASTM Adjuncts:<sup>3</sup>

ADJD3512 Set of 5 Photographic Standards for Random Tumble Pilling Test

### 3. Terminology

#### 3.1 Definitions:

3.1.1 *fuzz, n*—untangled fiber ends that protrude from the surface of a yarn or fabric.

3.1.2 *pilling resistance, n*—resistance to the formation of pills on the surface of a textile fabric.

3.1.3 *pills, n*—bunches or balls of tangled fibers which are held to the surface of a fabric by one or more fibers.

3.1.4 For definitions of other textile terms used in this test method, refer to Terminology D 123.

### 4. Summary of Test Method

4.1 Pilling and other changes in surface appearance, such as fuzzing, which occur in normal wear are simulated on laboratory testing machines. Fabrics are subjected to simulated wear conditions: first brushing the specimens to free fiber ends that form fuzz on the surface of the fabric, then rubbing two of the specimens together in circular motion to roll the fiber ends into pills. The

<sup>1</sup> This test method is under the jurisdiction of ASTM Committee D13 on Textiles and is the direct responsibility of Subcommittee D13.60 on Fabric Test Methods, Specific. Current edition approved Sept. July 1, 2005; 2007. Published October 2005; August 2007. Originally approved in 1976. Last previous edition approved in 2002 as D 3511 - 025.

<sup>2</sup> For referenced ASTM standards, visit the ASTM website, www.astm.org, or contact ASTM Customer Service at service@astm.org. For *Annual Book of ASTM Standards* volume information, refer to the standard's Document Summary page on the ASTM website.

<sup>3</sup> Available from ASTM Headquarters, 100 Barr Harbor Drive, West Conshohocken, PA 19428. Request ADJD3512.

degree of fabric pilling is evaluated by comparing the tested specimens with visual standards, which may be actual fabrics or photographs of fabrics, showing a range of pilling resistance. The observed resistance to pilling is reported using an arbitrary rating scale.

## 5. Significance and Use

5.1 *Acceptance Testing*—This method of testing fabrics for resistance to pilling is not recommended for acceptance testing. If it is used for acceptance testing, it should be used with caution because interlaboratory data are not available. In some cases the purchaser and the supplier may have to test a commercial shipment of one or more specific materials by the best available method, even though the method has not been recommended for acceptance testing.

5.1.1 If there are differences or practical significance between reported test results for two laboratories (or more), comparative tests should be performed to determine if there is a statistical bias between them, using competent statistical assistance. As a minimum, the test samples should be used that are as homogeneous as possible, drawn from the material from which the disparate test results were obtained, and randomly assigned in equal numbers to each laboratory for testing. Other materials with established test values may be used for this purpose. The test results from the two laboratories should be compared using a statistical test for unpaired data, at a probability level chosen prior to the testing series. If a bias is found, either its cause must be found and corrected, or future test results for that material must be adjusted in consideration of the known bias.

5.2 The pilling of textile fabrics is a very complex property because it is affected by many factors which may include type of fiber or blends, fiber dimensions, yarn and fabric construction, fabric finishing treatments and refurbishing method. Testing before refurbishing may be advisable. The pilling resistance of a specific fabric in actual wear varies more with general conditions of use and individual wearers than in replicate fabric specimens subjected to controlled laboratory tests. This experience should be borne in mind when adopting levels of acceptability for any series of standards.

5.3 Pills vary appreciably in size and appearance and depend on the presence of lint and degree of color contrast. These factors are not evaluated when pilling is rated solely on the number of pills. The development of pills may be accompanied by other surface phenomena such as loss of cover, color change, or the development of fuzz. Since the overall acceptability of a specific fabric is dependent on both the characteristics of the pills and the other factors affecting surface appearance, it is suggested that fabrics tested in the laboratory be evaluated subjectively with regard to their acceptability and not rated solely on the number of pills developed. A series of standards, based on graduated degrees of surface change of the fabric type being tested, may be set up to provide a basis for subjective ratings. The visual standards are most advantageous when the laboratory test specimens correlate closely in appearance with worn fabrics and show a similar ratio of pills to fuzz. Counting the pills and weighing their number with respect to their size and contrast, as a combined measure of pilling resistance, is not recommended because of the excessive time required for counting, sizing, and calculation.

5.4 The degree of fabric pilling is evaluated by comparing the tested specimens with visual standards, which may be actual fabrics or photographs of fabrics, showing a range of pilling resistance. The observed resistance to pilling is reported on an arbitrary scale ranging from 5 (no pilling) to 1 (very severe pilling).

5.5 This test method is applicable to a wide variety of woven and knitted fabrics that vary in pilling propensity as a result of variations in fiber, yarn & fabric structure, and finish.

## 6. Apparatus and Materials

6.1 *Brush Pilling Tester*<sup>4</sup>, (Fig. 1), consisting of the parts described as follows:

6.1.1 *Rotating Platform*, which operates on a 19-mm (0.75-in.) radius at 6.1 rad/s (1r/s).

6.1.2 *Nylon Brushes*, mounted on plywood holders, each of which is removable and is fitted to the rotating platform. The specifications for the brushes and accessories are as follows:

6.1.2.1 *Brushes*<sup>5</sup>—Fuller Gript Brush Strip, No. 8B904113, 790 mm (31 in.) long; eight per tester.

6.1.2.2 *Brush Strip Height*—A height of 24 mm (.94 in.) with an overall height of 32 mm (1.25 in.), including the backing but not the 9C-7200 holders.

6.1.2.3 *Brush Bristles*—Black nylon, 0.25-mm (10-mil) diameter.

6.1.2.4 *Brush Holders*—Fuller Brush No. 9C-7200,<sup>5</sup> 2-strip channel, 790 mm (31 in.) long.

6.1.2.5 *Brush Mounting*—9C-7200 holders spaced 35 mm (1.37 in.) center hole to center hole.

6.1.2.6 *Emery Paper 320*—Grit for sanding brushes.

6.1.2.7 *Cleaning Solvent*, acetone or other appropriate solvent to clean brushes (see 7.1 and 10.1.2).

6.1.3 *Specimen Holder*, (Fig. 2), six, each weighing  $660 \pm 5$  g, on which the fabric specimens are mounted. The face of the holders shall be covered with 3-mm (0.13 in) thick by 108-mm (4.25-in.) diameter soft cellular rubber<sup>6</sup> to prevent specimen slippage during testing.

<sup>4</sup> The Brush Pilling Tester manufactured by Standard Scientific Supply Co., 601 W. Market St., Bethlehem, PA 18018-5208 has been found satisfactory.

<sup>4</sup> The sole source of supply of the apparatus known to the committee at this time is Standard Scientific LLC, Bethlehem, PA. If you are aware of alternative suppliers, please provide this information to ASTM International Headquarters. Your comments will receive careful consideration at a meeting of the responsible technical committee, which you may attend.

<sup>5</sup> The Fuller Brush Co., Industrial Division, Hartford, CT 06115.

<sup>5</sup> Apparatus is commercially available.

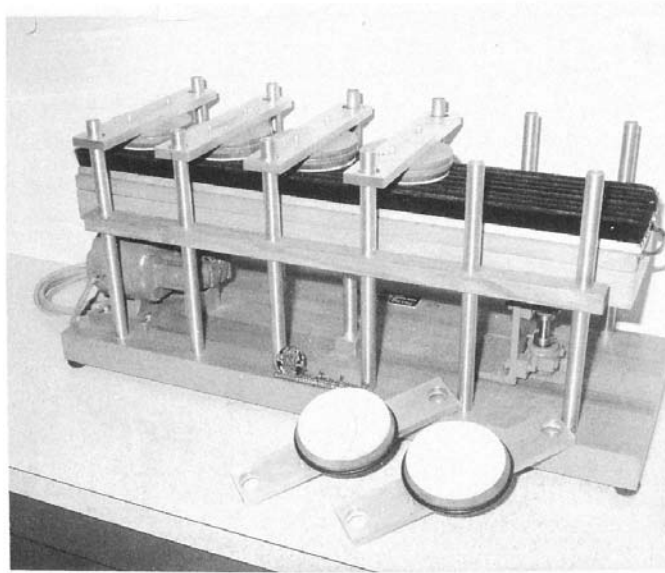

FIG. 1 Brush Pilling Tester

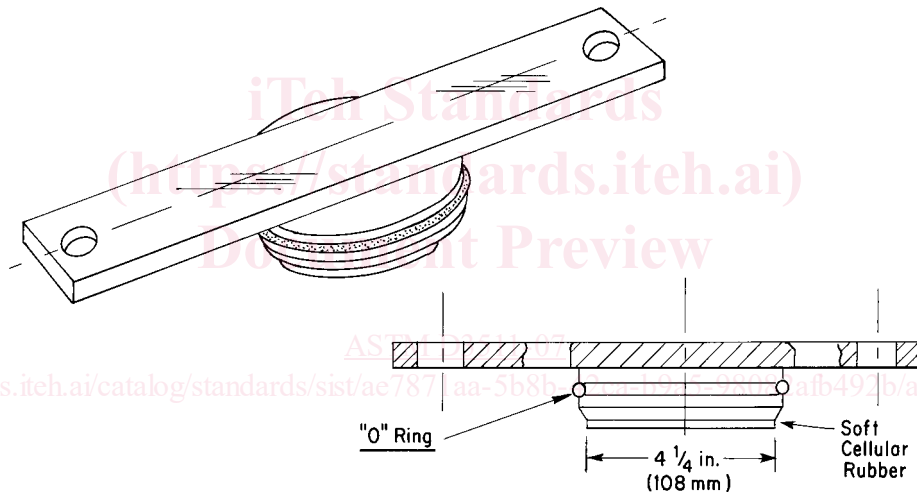

FIG. 2 Specimen Holder

6.2 *Apparatus for Fabric Evaluation*<sup>6</sup>Apparatus for Fabric Evaluation<sup>4</sup>(Fig. 3) — Facilities for illumination (cool white fluorescent tube) and simultaneous viewing of test specimen and fabric or photographic rating standards. Apparatus and options for visual evaluation are listed in Table 1.

6.3 *Standard In-House Pilling Test Fabric*, having an established pilling resistance rating, for checking machine performance. No universal standard fabric is available. Each test facility must decide on an appropriate fabric.

6.4 *Rating Standards:*

6.4.1 *Fabric*—A series of tested specimens of a specific type in-house fabric, which shows degrees of pilling or other distortions, or both, for each type of fabric to be tested. Store the in-house fabric rating standards and handle them under conditions that will preserve their original form and appearance.

6.4.2 *Photographic*—A set of five photographs, 105 mm square (4.13 in.), numbered 1 to 5, illustrating varying degrees of pilling from “very severe pilling” to “no pilling”, such as Adjunct D3511<sup>2</sup>ADJD3512. The photos should have a dull matte finish and be of the same size as the tested specimen.

6.4.3 Digital imaging and/or rating system.

6.5 *Facilities for Laundering Samples* —If needed.

6.6 *Facilities for Drycleaning Samples*—If needed.

7. **Hazardous Materials**

7.1 Solvents used in this test method may be hazardous. Refer to the manufacturer’s material safety data sheets for information on use, handling, storage, and disposal of these products.