**Implants for surgery — Wear of total
intervertebral spinal disc prostheses —**

Part 1:

**Loading and displacement parameters
for wear testing and corresponding
environmental conditions for test**

iTeh STANDARD PREVIEW

*Implants chirurgicaux — Usure des prothèses totales de remplacement
des disques intervertébraux lombaires —*

*Partie 1: Paramètres de charge et de déplacement pour essais d'usure
et conditions environnementales correspondantes*

<https://standards.iteh.ai/catalog/standards/sist/4673c5e4-4cc4-4ba1-b553-c863c840e5f8/iso-18192-1-2011>



PDF disclaimer

This PDF file may contain embedded typefaces. In accordance with Adobe's licensing policy, this file may be printed or viewed but shall not be edited unless the typefaces which are embedded are licensed to and installed on the computer performing the editing. In downloading this file, parties accept therein the responsibility of not infringing Adobe's licensing policy. The ISO Central Secretariat accepts no liability in this area.

Adobe is a trademark of Adobe Systems Incorporated.

Details of the software products used to create this PDF file can be found in the General Info relative to the file; the PDF-creation parameters were optimized for printing. Every care has been taken to ensure that the file is suitable for use by ISO member bodies. In the unlikely event that a problem relating to it is found, please inform the Central Secretariat at the address given below.

iTeh STANDARD PREVIEW
(standards.iteh.ai)

ISO 18192-1:2011

<https://standards.iteh.ai/catalog/standards/sist/4b73c5e4-4ce4-4baf-b533-c863c840e5f8/iso-18192-1-2011>



COPYRIGHT PROTECTED DOCUMENT

© ISO 2011

All rights reserved. Unless otherwise specified, no part of this publication may be reproduced or utilized in any form or by any means, electronic or mechanical, including photocopying and microfilm, without permission in writing from either ISO at the address below or ISO's member body in the country of the requester.

ISO copyright office
Case postale 56 • CH-1211 Geneva 20
Tel. + 41 22 749 01 11
Fax + 41 22 749 09 47
E-mail copyright@iso.org
Web www.iso.org

Published in Switzerland

Contents

Page

Foreword	iv
1 Scope	1
2 Normative references	1
3 Terms and definitions	1
4 Principle	2
5 Reagents and materials	3
5.1 Fluid test medium	3
5.2 Test and control specimen	3
6 Apparatus	4
7 Procedure	8
8 Test report	9
9 Disposal of test specimen	10
Annex A (informative) Statement of rationale for test methods	11
Annex B (informative) Load and displacement data for cervical implants	12
Annex C (informative) Load and displacement data for lumbar implants	13
Annex D (informative) Alternative loading conditions	14
Bibliography	25

Foreword

ISO (the International Organization for Standardization) is a worldwide federation of national standards bodies (ISO member bodies). The work of preparing International Standards is normally carried out through ISO technical committees. Each member body interested in a subject for which a technical committee has been established has the right to be represented on that committee. International organizations, governmental and non-governmental, in liaison with ISO, also take part in the work. ISO collaborates closely with the International Electrotechnical Commission (IEC) on all matters of electrotechnical standardization.

International Standards are drafted in accordance with the rules given in the ISO/IEC Directives, Part 2.

The main task of technical committees is to prepare International Standards. Draft International Standards adopted by the technical committees are circulated to the member bodies for voting. Publication as an International Standard requires approval by at least 75 % of the member bodies casting a vote.

Attention is drawn to the possibility that some of the elements of this document may be the subject of patent rights. ISO shall not be held responsible for identifying any or all such patent rights.

ISO 18192-1 was prepared by Technical Committee ISO/TC 150, *Implants for surgery*, Subcommittee SC 5, *Osteosynthesis and spinal devices*.

This second edition cancels and replaces the first edition (ISO 18192-1:2008), of which it constitutes a minor revision. The main modifications are the introduction of the term “cycle limit” (an explicit statement that a different cycle limit can be used with appropriate justification) and the change of the required concentration of calf serum in the fluid test medium to 20 g protein/l.

ISO 18192 consists of the following parts, under the general title *Implants for surgery — Wear of total intervertebral spinal disc prostheses*:

- *Part 1: Loading and displacement parameters for wear testing and corresponding environmental conditions for test*
- *Part 2: Nucleus replacements*

Implants for surgery — Wear of total intervertebral spinal disc prostheses —

Part 1: Loading and displacement parameters for wear testing and corresponding environmental conditions for test

1 Scope

This part of ISO 18192 defines a test procedure for the relative angular movement between articulating components, and specifies the pattern of the applied force, speed and duration of testing, sample configuration and test environment for use for the wear testing of total intervertebral spinal disc prostheses.

Both lumbar and cervical prostheses are addressed. This part of ISO 18192 is not applicable to partial disc replacements, such as nucleus replacements or facet joint replacements. The test method focuses on wear testing. Additional mechanical tests, such as fatigue testing, can be required.

This part of ISO 18192 does not reproduce the complex *in vivo* loads and motions. The wear data obtained with this test method enables comparison between different types of implants, but can differ from the clinical wear performance. The user of this part of ISO 18192 can consider running additional wear tests addressing specific safety issues of the individual implant design under test.

2 Normative references

The following referenced documents are indispensable for the application of this document. For dated references, only the edition cited applies. For undated references, the latest edition of the referenced document (including any amendments) applies.

ISO 14242-2, *Implants for surgery — Wear of total hip-joint prostheses — Part 2: Methods of measurement*

3 Terms and definitions

For the purposes of this document, the following terms and definitions apply.

3.1

axial rotation

angular movement in the transverse plane around the Z-axis

See Figure 1 c).

3.2

flexion/extension

angular movement in the sagittal plane around the Y-axis

See Figure 1 a).

3.3 functional failure
failure that renders the implant unable to resist the load and/or move as initially intended by the design of the implant

3.4 lateral bending
angular movement in the frontal plane around the X-axis

See Figure 1 b).

3.5 mechanical failure
onset of a defect in the material

EXAMPLE Initiation of fatigue crack.

3.6 origin
centre of the coordinate system located at the instantaneous centre of rotation at the neutral position of the total disc replacement

NOTE The nominal centre is specified by the design.

3.7 user-defined failure
any failure criterion that is established and controlled by the user considering the specific design of the implant to be tested

iTeh STANDARD PREVIEW
(standards.iteh.ai)

3.8 X-axis
positive X-axis directed anteriorly

ISO 18192-1:2011
<http://standards.iteh.ai/catalog/standards/sist/4b73c5e4-4ce4-4baf-b533-c863c840e5f8/iso-18192-1-2011>

See Figure 1.

3.9 Y-axis
positive Y-axis directed laterally to the left

See Figure 1.

3.10 Z-axis
positive Z-axis directed superiorly

See Figure 1.

3.11 cycle limit
number of cycles at which the test is terminated if no functional failure has occurred

4 Principle

The inferior and superior components of a test specimen are placed in position in the configuration intended for clinical use. The test apparatus transmits a specified time-varying force between the components, together with specified relative angular displacements. A load soak control specimen, if polymers are the object of investigation, is subjected to the same time-varying force to determine the creep of the test specimen and/or the amount of mass change due to fluid transfer. The test takes place in a controlled environment simulating physiological conditions.

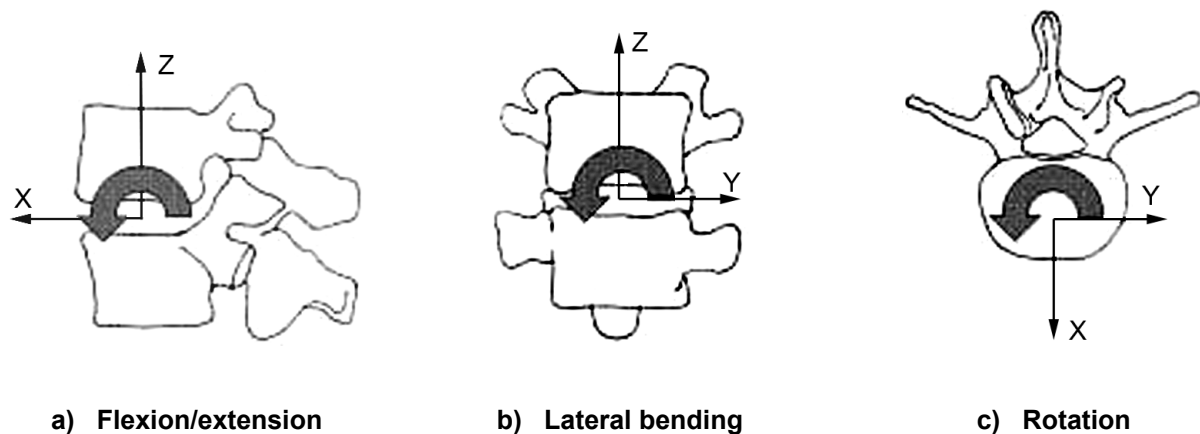

Figure 1 — Definition of the angular movements and coordinate axes

5 Reagents and materials

5.1 Fluid test medium

Calf serum diluted with de-ionized water (balance) to a concentration of $20 \text{ g} \pm 2 \text{ g}$ protein/l.

The fluid test medium may be filtered through a $2 \mu\text{m}$ filter if desired.

To minimize microbial contamination, the fluid test medium should be stored frozen until required for test. An antimicrobial reagent (such as sodium azide) may be added. Such reagents can be potentially hazardous.

<https://standards.iteh.ai/catalog/standards/sist/4b73c5e4-4ce4-4baf-b533->

The addition of 20 mmol/l EDTA solution may be used to bind calcium in solution and to minimize precipitation of calcium phosphate on to the bearing surfaces. The effect of EDTA depends on the material combination tested. The addition of EDTA shall be justified by the user.

Routine monitoring of the pH of the fluid test medium should be undertaken. If it is, the values shall be included in the test report [see 8 k) 6)].

5.2 Test and control specimen

Between the inferior and superior components shall be the articulating surface of the inferior and superior components, attached by its normal immediate backing (for example bone cement or a machined replica of the inner surface of the backing), unless this is impractical due to physical features of the implant system. If the component forming the articulating surface is fixed to the backing by a rim/snap-fit system, the machined replica shall provide the same fixation conditions.

If it is not practical to use the normal backing or cement fixation due to physical features of the implant system, the support system for the inferior and/or superior component should represent normal design features and conditions of use but should allow removal of the component for measurement of wear without destruction.

A recommended minimum sample number of six should be used for wear testing. If less than six specimens are tested, appropriate justification shall be given.

NOTE The number of specimens tested can be the subject of national legislation.

At least one additional sample shall be used to correct weight gain by fluid uptake (load soak control). The load soak control shall be loaded according to the load profile given for the type of implant. The user may decide not to use a soak control when testing materials that do not absorb surrounding fluid (for example metal materials).

6 Apparatus

6.1 Testing machine, capable of producing the angular displacements specified in Table 1 and Figures 2 and 3 in association with the corresponding forces specified in Table 2 and operating at a frequency of $(1 \pm 0,1)$ Hz based on one cycle being the shortest repetitive interval for all motions and loads combined.

Table 1 — Angular displacements of the testing machine

Implant	Angle	Flexion/extension	Axial rotation	Lateral bending
Cervical	min.	-7,5°	-4°	-6°
	max.	7,5	4°	6°
Lumbar	min.	-3°	2°	2°
	max.	6°	-2°	-2°

The angular displacements indicated may be varied according to data given by the test requester.

Table 2 — Load parameters of the testing machine

Implant	Load N
Cervical	max. 150
	min. 50
Lumbar	max. 2 000
	min. 600

The load parameters indicated may be varied according to data given by the test requester.

A defined level of shear loading shall be implemented for lumbar implants being restrained in the transverse plane. Shear loading is achieved by inclining the implant with respect to the axial load axis in the sagittal plane at the reference position (see Figure 4). Certain designs can be sensitive to shear loads. The user may intensify the test conditions by increasing the shear load and/or adding alternating load directions.

NOTE 1 It is the responsibility of the user of this part of ISO 18192 to be aware that a certain amount of shear load is generated by the motion of the device with respect to the axial load. With regard to the implant design, it is intended that the user give a justification for intended physiological conditions, especially for motion of any articulating surfaces during the load and motion cycle.

NOTE 2 See Annex A for load and motion rationale.

All angular displacement curves and load curves are smooth. The curves shall reach the given values at 0 %, 25 %, 50 % and 75 % of the motion cycle within the tolerances given in 6.4. Sample data sets are provided in Annexes B and C.

The angles refer to a moving coordinate system.

The intended sequence of the angular transformation is: lateral bending — flexion/extension — axial rotation.

NOTE 3 The sequence of the axial rotations slightly impacts the motion and the final position after each motion step (Euler angles). Due to the small angles applied, Euler sequences differing from the above result in almost identical relative motions. The Euler sequence chosen can be selected according to the mechanical set-up of the wear testing machine.

NOTE 4 The load curve is sinusoidal.

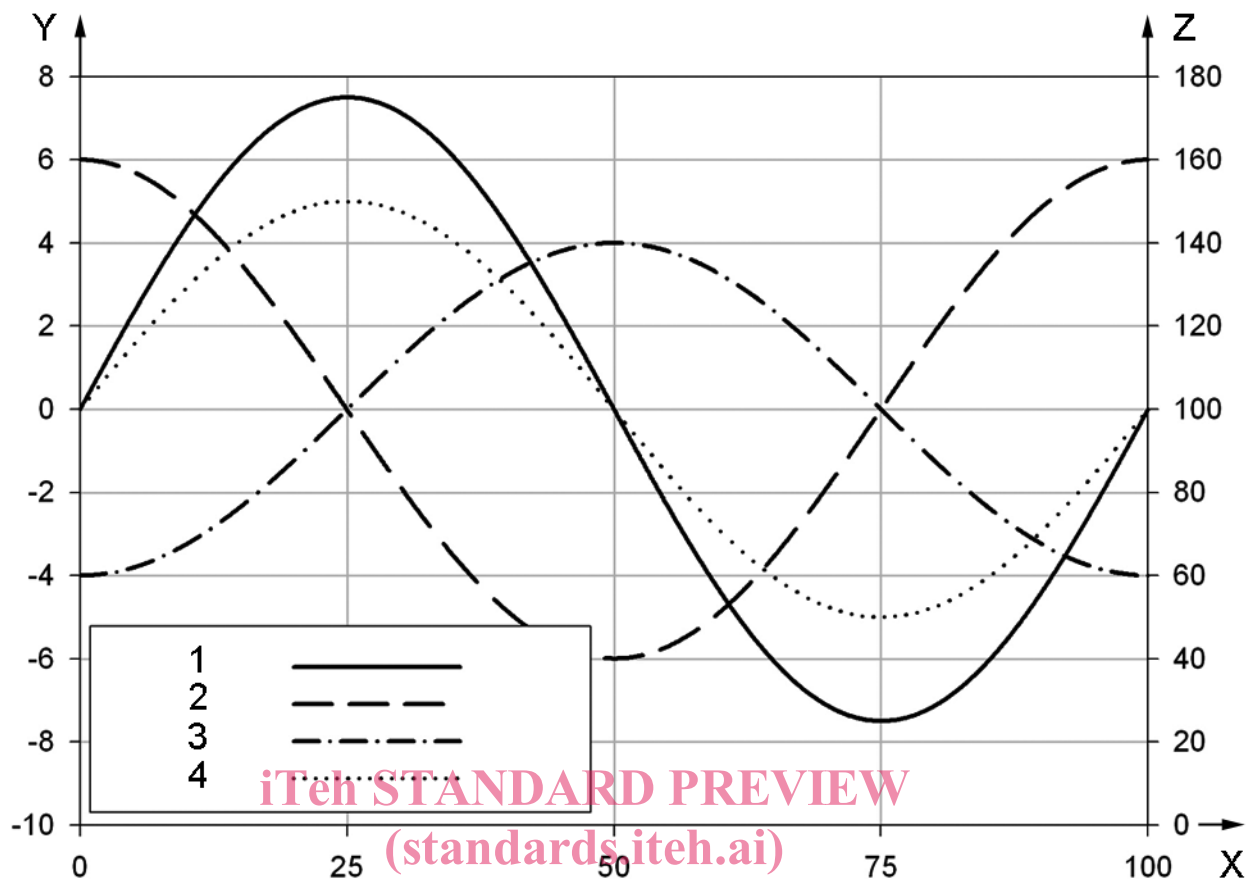

Key

- X cycle (%)
- Y angle (°)
- Z load (N)

- 1 flexion/extension
- 2 lateral bending
- 3 rotation
- 4 load

<https://standards.iteh.ai/catalog/standards/sist/4b73c5e4-4ce4-4baf-b533-c863c840e5f8/iso-18192-1-2011>
 ISO 18192-1:2011

The lateral bending is shifted 90° relative to the flexion/extension axis; the axial rotation and the lateral bending are 180° out of phase.

Figure 2 — Phasing of the displacement and load curves for cervical prostheses

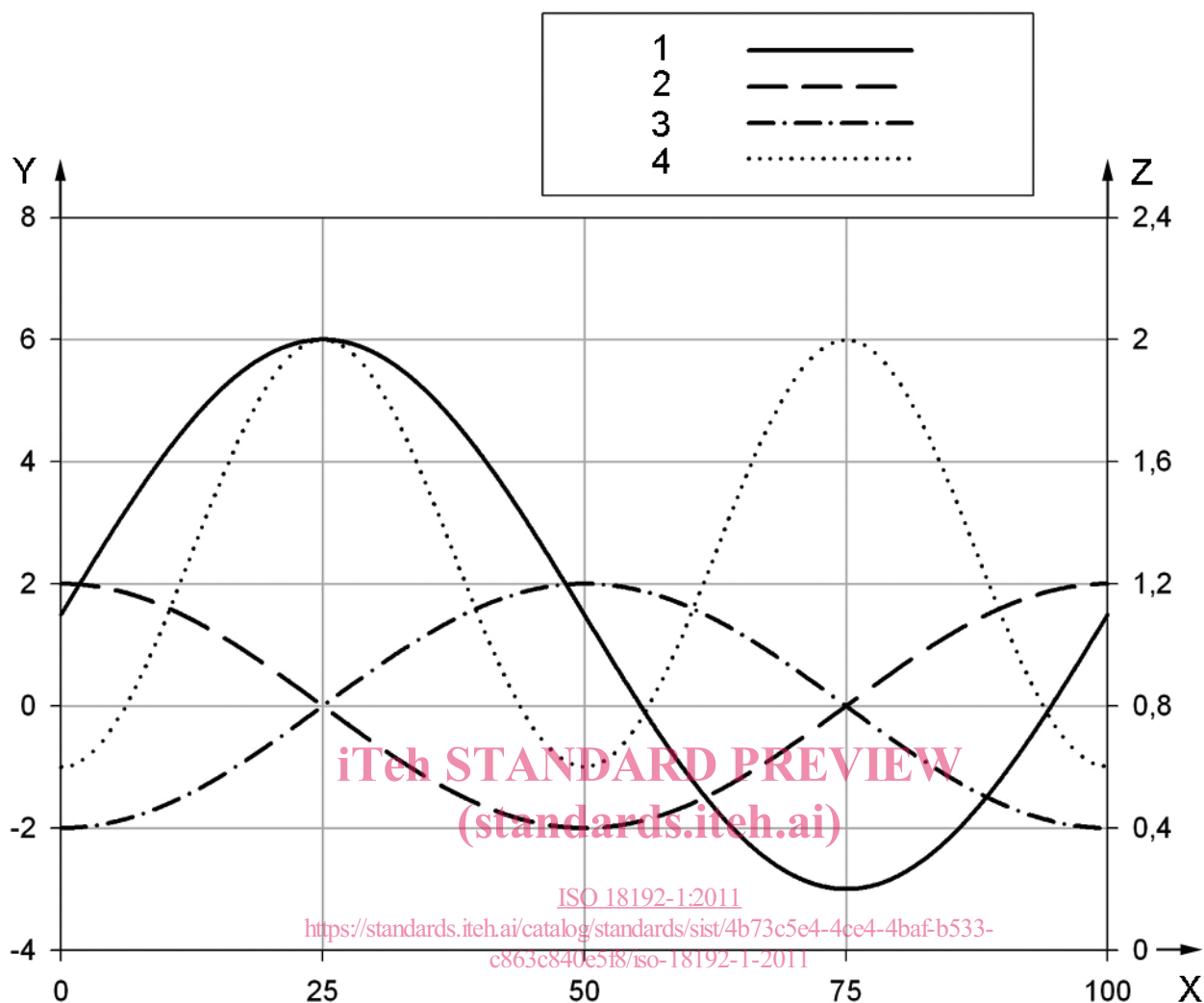

Key

- X cycle (%)
- Y angle (°)
- Z load (kN)

- 1 flexion/extension
- 2 lateral bending
- 3 rotation
- 4 load

The lateral bending is shifted 90° relative to the flexion/extension axis; the axial rotation and the lateral bending are 180° out of phase.

Figure 3 — Phasing of the displacement and load curves for lumbar prostheses

6.2 Means of mounting and enclosing the test specimen, of corrosion-resistant material, capable of holding inferior and superior components using attachment methods comparable to the intended anatomical fixation.

6.3 Means of aligning and positioning, to align the superior component of the test specimen in the superior position, so that its instantaneous axis of rotation at the neutral position is situated at the centre of the axes of rotation of the test machine and the same position and orientation can be reproduced following removal for measurement or cleaning, if required.

Align the inferior component of the test specimen, so that its instantaneous axis of rotation at the neutral position is situated at the centre of the axes of rotation of the test machine and the same position and orientation can be reproduced following removal for measurement. This alignment is intended to prevent preloads in the initial test position.

Incline the Z-axis of lumbar implants 10° with respect to the load axis to generate enhanced shear (see Figure 4). The shear load is intended to act from posterior to anterior. Cervical implants are not inclined with respect to the axial load.

NOTE 1 Some designs using mobile bearings can generate less wear if the mobile bearing is forced by the shear load to remain in one position. In this case, it is intended that the user use no inclination to generate worst case conditions.

NOTE 2 Shear forces act on the device due to the cyclic inclination with respect to the axial load.

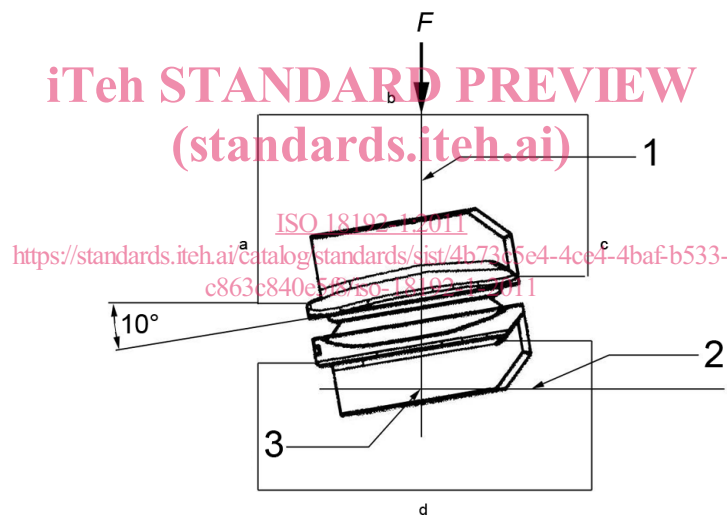

Key

- 1 rotation axis
- 2 lateral bending axis
- 3 centre of rotation

F axial force

- a Anterior.
- b Superior.
- c Posterior.
- d Inferior.

Figure 4 — Inclination of the lumbar implant in the sagittal plane to simulate shear loading

6.4 Motion control system, capable of generating the angular movements of the superior component as given in Figures 2 and 3 with an accuracy of $\pm 0,5^\circ$ at the maxima and minima of the motion and $\pm 2\%$ of the full cycle time for phasing. For multi-station test systems, capabilities shall be assessed with all stations active.

6.5 Force control system, capable of generating a force in the z -direction (see Figure 1), which varies as shown in Figures 2 and 3, and capable of maintaining the magnitude of the maxima and minima of this force cycle to a tolerance of $\pm 5\%$ of the maximum force value for the cycle and $\pm 3\%$ of the full cycle time for phasing. For multi-station test systems, capabilities shall be assessed with all stations active.

6.6 Lubrication system, capable of maintaining the contact surfaces immersed in the fluid test medium.

NOTE The use of sealed enclosures can prevent evaporation and contamination.

6.7 Temperature control system, capable of maintaining the temperature of the fluid test medium (see 5.1) at $(37 \pm 2)^\circ\text{C}$.

6.8 Control station(s), capable of applying the loading regime shown in Figures 2 and 3 and incorporating the requirements given in 6.2, 6.3, 6.6 and 6.7.

7 Procedure

7.1 Clean the test specimen.

Cleaning of the test specimen may be carried out as described in ISO 14242-2 or by an alternative method.

7.2 Make any initial measurements required to determine the subsequent amount of wear and/or creep. Calibrate all test stations with a time-varying load to ensure the system load meets the requirements in 6.5. For multi-station test systems, perform calibration with all stations active.

NOTE Methods of measurement of wear are given in ISO 14242-2.
<https://www.iso.org/standard/4673c5e4-4ce4-4baf-b533-c863c840e5f8/iso-18192-1-2011>

7.3 Mount the specimen in the testing machine.

7.4 Take the load soak control specimen and repeat steps in 7.1, 7.2 and 7.3.

7.5 Introduce fresh fluid test medium (see 5.1) to completely immerse the contact surfaces of the test specimen and the control specimen. Maintain the temperature of the fluid test medium at $(37 \pm 2)^\circ\text{C}$, taking the measurement at a location representative of the bulk temperature of the fluid. Determine the pH value (optional).

7.6 Wait until the specimen has reached a steady-state temperature.

7.7 Start the testing machine and adjust it so that the loads and displacements specified in Figures 1 to 3 are applied to the test specimen (see 6.4 and 6.5). The curves between the defined maxima and minima in Figures 2 and 3 shall be smooth with no overshoots. Record the displacement and load waveforms at start-up, and after each change of fluid test medium, for every single test station, if independent test stations are used, and for one test station, if mechanically connected test stations are used.

7.8 Operate the testing machine at a frequency of 1 Hz with an accuracy of $\pm 0,1$ Hz. 1 Hz refers to one cycle per second, where one cycle is defined as the shortest repetitive interval for all motions and loads combined. Test frequencies up to 2 Hz may be used. The impact of test frequencies higher than 1 Hz on the implant material behaviour as well as on the accuracy of the test machine shall be investigated by the user. Adequate justification shall be given by the user.

7.9 Replace the fluid lost by evaporation during the test at least daily, by adding de-ionized water. Replace the fluid test medium completely at least every 5×10^5 cycles, or every seven days, whichever is the shorter.