



SLOVENSKI STANDARD

SIST EN 1367-5:2002

01-december-2002

Preskusi lastnosti agregatov zaradi termičnih in vremenskih vplivov - 5. del: Določevanje odpornosti proti temperaturnemu šoku

Tests for thermal and weathering properties of aggregates - Part 5: Determination of resistance to thermal shock

Prüfverfahren für thermische Eigenschaften und Verwitterungsbeständigkeit von Gesteinskörnungen - Teil 5: Bestimmung des Widerstandes gegen Hitzebeanspruchung

Essais pour déterminer les propriétés thermiques et l'altérabilité des granulats - Partie 5 : Détermination de la résistance au choc thermique

<https://standards.iteh.ai/catalog/standards/sist/4b63e9b3-327c-4e1e-ba07-94afaa0b5fcf/sist-en-1367-5-2002>

Ta slovenski standard je istoveten z: EN 1367-5:2002

ICS:

91.100.15 Mineralni materiali in izdelki Mineral materials and products

SIST EN 1367-5:2002

en

iTeh STANDARD PREVIEW
(standards.iteh.ai)

[SIST EN 1367-5:2002](https://standards.iteh.ai/catalog/standards/sist/4b63e9f3-327c-4e1e-ba07-94afaa0b5fcf/sist-en-1367-5-2002)

<https://standards.iteh.ai/catalog/standards/sist/4b63e9f3-327c-4e1e-ba07-94afaa0b5fcf/sist-en-1367-5-2002>

EUROPEAN STANDARD
NORME EUROPÉENNE
EUROPÄISCHE NORM

EN 1367-5

August 2002

ICS 91.100.15; 93.080.20

English version

Tests for thermal and weathering properties of aggregates - Part 5: Determination of resistance to thermal shock

Essais pour déterminer les propriétés thermiques et
l'altérabilité des granulats - Partie 5: Détermination de la
résistance au choc thermique

Prüfverfahren für thermische Eigenschaften und
Verwitterungsbeständigkeit von Gesteinskörnungen - Teil 5:
Bestimmung des Widerstandes gegen Hitzebeanspruchung

This European Standard was approved by CEN on 10 May 2002.

CEN members are bound to comply with the CEN/CENELEC Internal Regulations which stipulate the conditions for giving this European Standard the status of a national standard without any alteration. Up-to-date lists and bibliographical references concerning such national standards may be obtained on application to the Management Centre or to any CEN member.

This European Standard exists in three official versions (English, French, German). A version in any other language made by translation under the responsibility of a CEN member into its own language and notified to the Management Centre has the same status as the official versions.

CEN members are the national standards bodies of Austria, Belgium, Czech Republic, Denmark, Finland, France, Germany, Greece, Iceland, Ireland, Italy, Luxembourg, Malta, Netherlands, Norway, Portugal, Spain, Sweden, Switzerland and United Kingdom.

[SIST EN 1367-5:2002](https://standards.iteh.ai/catalog/standards/sist/4b63e9b3-327c-4e1e-ba07-94afaa0b5fcf/sist-en-1367-5-2002)

<https://standards.iteh.ai/catalog/standards/sist/4b63e9b3-327c-4e1e-ba07-94afaa0b5fcf/sist-en-1367-5-2002>



EUROPEAN COMMITTEE FOR STANDARDIZATION
COMITÉ EUROPÉEN DE NORMALISATION
EUROPÄISCHES KOMITEE FÜR NORMUNG

Management Centre: rue de Stassart, 36 B-1050 Brussels

Contents

	page
Foreword.....	3
1 Scope	4
2 Normative references	4
3 Terms and definitions.....	4
4 Principle	4
5 Apparatus	5
6 Sampling	7
7 Procedure	7
8 Calculation and expression of results	8
9 Test report	8

iTeh STANDARD PREVIEW (standards.iteh.ai)

[SIST EN 1367-5:2002](https://standards.iteh.ai/catalog/standards/sist/4b63e9f3-327c-4e1e-ba07-94afaa0b5fcf/sist-en-1367-5-2002)

<https://standards.iteh.ai/catalog/standards/sist/4b63e9f3-327c-4e1e-ba07-94afaa0b5fcf/sist-en-1367-5-2002>

Foreword

This European Standard has been prepared by Technical Committee CEN/TC 154 "Aggregates", the secretariat of which is held by BSI.

This European Standard shall be given the status of a national standard, either by publication of an identical text or by endorsement, at the latest by February 2003, and conflicting national standards shall be withdrawn at the latest by December 2003.

This standard forms part of a series of tests for thermal and weathering properties of aggregates. Test methods for other properties of aggregates will be covered by parts of the following European Standards:

EN 932	<i>Tests for general properties of aggregates.</i>
EN 933	<i>Tests for geometrical properties of aggregates.</i>
EN 1097	<i>Tests for mechanical and physical properties of aggregates.</i>
EN 1744	<i>Tests for chemical properties of aggregates.</i>
EN 13179	<i>Tests for filler aggregate used in bituminous mixtures.</i>

The other parts of EN 1367 will be:

Part 1: Determination of resistance to freezing and thawing.

Part 2: Magnesium sulfate test.

Part 3: Boiling test for "Sonnenbrand basalt".

Part 4: Determination of drying shrinkage.

According to the CEN/CENELEC Internal Regulations, the national standards organizations of the following countries are bound to implement this European Standard: Austria, Belgium, Czech Republic, Denmark, Finland, France, Germany, Greece, Iceland, Ireland, Italy, Luxembourg, Malta, Netherlands, Norway, Portugal, Spain, Sweden, Switzerland and the United Kingdom.

EN 1367-5:2002 (E)

1 Scope

This European Standard specifies methods for the determination of resistance to thermal shock of aggregates, subject to heating and drying in the production of hot bituminous mixtures.

2 Normative references

This European Standard incorporates by dated or undated reference, provisions from other publications. These normative references are cited at the appropriate places in the text, and the publications are listed hereafter. For dated references, subsequent amendments to or revisions of any of these publications apply to this European Standard only when incorporated in it by amendment or revision. For undated references the latest edition of the publication referred to applies (including amendments).

EN 932-1, *Tests for general properties of aggregates — Part 1: Methods for sampling.*

EN 932-5, *Tests for general properties of aggregates — Part 5: Common equipment and calibration.*

EN 933-2, *Tests for geometrical properties of aggregates — Part 2: Determination of particle size distribution – Test sieves, nominal size of apertures.*

EN 1097-2:1998, *Tests for mechanical and physical properties of aggregates — Part 2: Methods for the determination of resistance to fragmentation.*

3 Terms and definitions

For the purposes of this European Standard the following terms and definitions apply.

3.1

thermal shock

change in physical properties of aggregates subjected to 700 °C environment for a 3 min interval

3.2

test portion

sample used as a whole in a single test

3.3

constant mass

successive weighings after drying at least 1 h apart not differing by more than 0,1 %

NOTE In many cases constant mass can be achieved after a test portion has been dried for a pre-determined period in a specified oven at $(110 \pm 5) ^\circ \text{C}$. Test laboratories can determine the time required to achieve constant mass for specified types and sizes of sample dependent on the drying capacity of the oven used.

4 Principle

The test involves heating soaked aggregates to 700 °C for 3 min and calculating the increase in undersize passing the 5 mm sieve after thermal shock. The resistance to fragmentation is then determined in accordance with EN 1097-2 on a sample after heating and the strength loss calculated by comparison with the result of a sample which has not been heated.

5 Apparatus

5.1 General

All apparatus, unless otherwise stated, shall conform to the general requirements of EN 932-5.

5.2 Apparatus for heat test

5.2.1 Distilled or deionised water.

5.2.2 Furnace or oven, heated by radiation only, capable of maintaining test portions at a temperature of (700 ± 100) °C for the specified time period using a suitable control system.

The minimum internal dimensions shall be:

- a) width – 260 mm;
- b) height – 160 mm;
- c) depth – 450 mm.

5.2.3 Test sieves conforming to EN 933-2 with aperture sizes as specified in Table 1.

Table 1 — Test sieves

Test	Aperture size mm
Thermal shock	5
Los Angeles	1,6 10 11,2 (or 12,5) 14
Impact test	0,2 0,63 2 5 8 10 11,2 12,5

5.2.4 Balance of adequate capacity, with an accuracy of $\pm 0,5$ g. Ventilated drying oven, with forced circulation of adequate capacity.

5.2.5 Ventilated drying oven, with forced circulation of adequate capacity. The oven shall be capable of being controlled at (110 ± 5) °C.

5.2.6 Heat resistant metal test plate, thickness $(4 \pm 0,5)$ mm, length (440 ± 5) mm, width (240 ± 5) mm and provided with a turned up lip of height (12 ± 1) mm, see Figure 1.

5.2.7 Metal support frame or grid, for the test plate to give a clearance height of at least 10 mm between the base of the test plate and the bottom of the furnace.

NOTE An example is given in Figure 2.

5.2.8 Heat resistant plate, thickness (10 ± 1) mm, length (450 ± 5) mm, width (250 ± 5) mm.

5.2.9 Tongs, to transfer the test plate to and from the furnace.

5.2.10 Scoop, flat based 220 mm wide by 350 mm long, to spread the test portion on the test plate.

5.2.11 Heat resistant metal sieve fabric of approximately 2 mm aperture, size (250 ± 5) mm by (445 ± 5) mm, to cover the test portion.

5.2.12 Metal receiver, large enough to hold the test portion.

5.2.13 Absorbent cloth or towel of adequate size.

Dimensions in millimetres

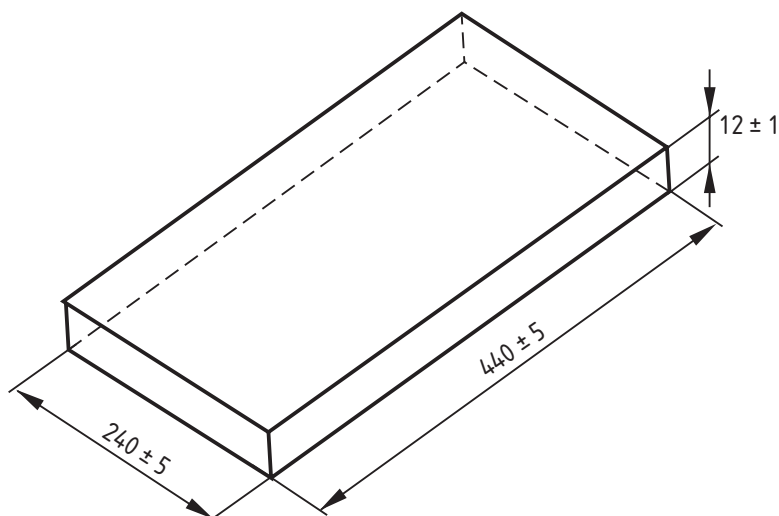
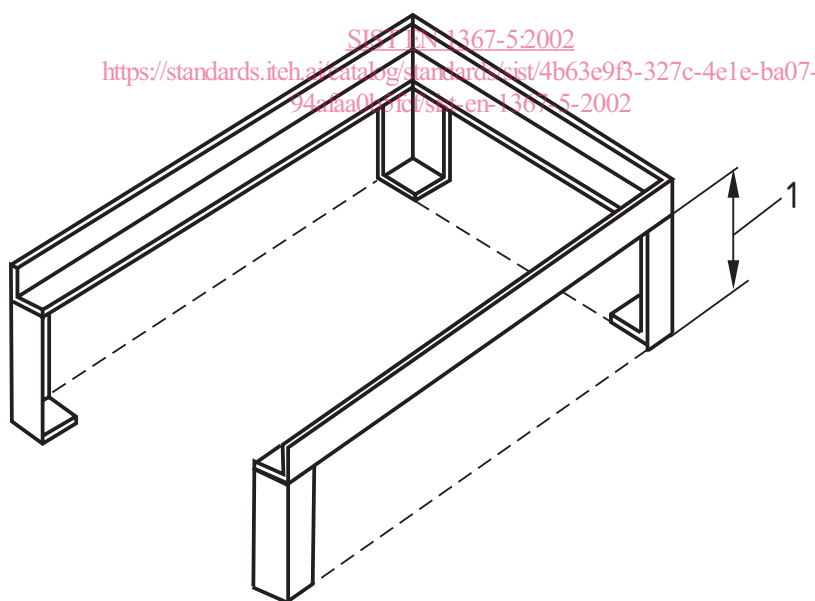

Figure 1 — Metal test plate
(standards.iteh.ai)

**Key**

1 At least 10 mm

Figure 2 — Example of the support for the metal plate

6 Sampling

Sampling shall be in accordance with EN 932-1. The mass of the laboratory sample shall be large enough to allow two strength tests to be carried out in accordance with EN 1097-2:1998, 5.2 or 6.2, as appropriate. One test portion shall be tested without heating and one test portion shall be tested after exposure to thermal shock. Each test portion shall be of the appropriate particle size fraction and mass, in accordance with EN 1097-2:1998, 5.2 or 6.2.

NOTE The size of the test portion exposed to thermal shock should be larger than that tested without heating, because particles can degrade in the oven.

7 Procedure

7.1 Preparation of test portions

Wash and dry the test portions to constant mass. Weigh the first test portion and record the mass in grams as M_1 .

7.2 Exposure to thermal shock

Place the first test portion in a container and cover with deionised water to a depth of 20 mm above the aggregate surface and allow to soak for $(2 \pm 0,5)$ h at room temperature.

Gently pour the aggregate and spread it out on the water absorbing cloth. Gently dry the aggregate with the free ends of the cloth, until visibly surface dry.

Raise the furnace temperature to (700 ± 50) °C and maintain for the duration of the test period.

Heat the test plate in the furnace for at least 5 min, and remove and place on the heat resistant plate. Transfer an increment of approximately 1 000 g of the prepared test portion with the scoop and spread evenly on the pre-heated test plate. Cover the aggregate with the metal sieve fabric and immediately transfer the test plate and contents to the furnace, close the door and allow the test portion to heat for (180 ± 5) s.

Remove the test plate from the furnace and place on the heat resistant plate. Quickly transfer the increment to the receiver and allow to cool.

Repeat this procedure with 1 000 g increments.

The period between transferring the aggregate from the furnace to the receiver, and recharging the test plate with a fresh increment, replacing in the furnace and closing the door, shall not exceed 20 s.

When the whole test portion has been taken from the furnace and transferred to the receiver, allow to cool to room temperature. Sieve out the size fraction passing the 5 mm sieve and record the mass in grams as M_2 .

7.3 Determination of resistance to fragmentation

Determine the resistance to fragmentation on the test portion exposed to thermal shock in accordance with EN 1097-2:1998, 5.3 or 6.3 as appropriate.

Repeat the same fragmentation test on the second test portion which has not been exposed to thermal shock.