



Designation: D7137/D7137M – 07

Standard Test Method for Compressive Residual Strength Properties of Damaged Polymer Matrix Composite Plates¹

This standard is issued under the fixed designation D7137/D7137M; the number immediately following the designation indicates the year of original adoption or, in the case of revision, the year of last revision. A number in parentheses indicates the year of last approval. A superscript epsilon (ϵ) indicates an editorial change since the last revision or reapproval.

1. Scope

1.1 This test method covers compression residual strength properties of multidirectional polymer matrix composite laminated plates, which have been subjected to quasi-static indentation per Test Method [D6264/D6264M](#) or drop-weight impact per Test Method [D7136/D7136M](#) prior to application of compressive force. The composite material forms are limited to continuous-fiber reinforced polymer matrix composites with multidirectional fiber orientations, and which are both symmetric and balanced with respect to the test direction. The range of acceptable test laminates and thicknesses is defined in [8.2](#).

NOTE 1—When used to determine the residual strength of drop-weight impacted plates, this test method is commonly referred to as the Compression After Impact, or CAI, method.

1.2 The method utilizes a flat, rectangular composite plate, previously subjected to a damaging event, which is tested under compressive loading using a stabilization fixture.

NOTE 2—The damage tolerance properties obtained are particular to the type, geometry and location of damage inflicted upon the plate.

1.3 The properties generated by this test method are highly dependent upon several factors, which include specimen geometry, layup, damage type, damage size, damage location, and boundary conditions. Thus, results are generally not scalable to other configurations, and are particular to the combination of geometric and physical conditions tested.

1.4 This test method can be used to test undamaged polymer matrix composite plates, but historically such tests have demonstrated a relatively high incidence of undesirable failure modes (such as end crushing). Test Method [D6641/D6641M](#) is recommended for obtaining compressive properties of undamaged polymer matrix composites.

1.5 The values stated in either SI units or inch-pound units are to be regarded separately as standard. Within the text the inch-pound units are shown in brackets. The values stated in each system are not exact equivalents; therefore, each system

must be used independently of the other. Combining values from the two systems may result in nonconformance with the standard.

1.6 *This standard does not purport to address all of the safety concerns, if any, associated with its use. It is the responsibility of the user of this standard to establish appropriate safety and health practices and determine the applicability of regulatory limitations prior to use.*

2. Referenced Documents

2.1 *ASTM Standards:*²

[D792](#) Test Methods for Density and Specific Gravity (Relative Density) of Plastics by Displacement

[D883](#) Terminology Relating to Plastics

[D3171](#) Test Methods for Constituent Content of Composite Materials

[D3878](#) Terminology for Composite Materials

[D5229/D5229M](#) Test Method for Moisture Absorption Properties and Equilibrium Conditioning of Polymer Matrix Composite Materials

[D5687/D5687M](#) Guide for Preparation of Flat Composite Panels with Processing Guidelines for Specimen Preparation

[D6264/D6264M](#) Test Method for Measuring the Damage Resistance of a Fiber-Reinforced Polymer-Matrix Composite to a Concentrated Quasi-Static Indentation Force

[D6641/D6641M](#) Test Method for Compressive Properties of Polymer Matrix Composite Materials Using a Combined Loading Compression (CLC) Test Fixture

[D7136/D7136M](#) Test Method for Measuring the Damage Resistance of a Fiber-Reinforced Polymer Matrix Composite to a Drop-Weight Impact Event

[E4](#) Practices for Force Verification of Testing Machines

[E6](#) Terminology Relating to Methods of Mechanical Testing

[E122](#) Practice for Calculating Sample Size to Estimate, With Specified Precision, the Average for a Characteristic of a Lot or Process

[E177](#) Practice for Use of the Terms Precision and Bias in

¹ This test method is under the jurisdiction of ASTM Committee [D30](#) on Composite Materials and is the direct responsibility of Subcommittee [D30.05](#) on Structural Test Methods.

Current edition approved Nov. 15, 2007. Published December 2007. Originally approved in 2005. Last previous edition approved in 2005 as [D7137/D7137M-05^{ε1}](#). DOI: 10.1520/D7137_D7137M-07.

² For referenced ASTM standards, visit the ASTM website, www.astm.org, or contact ASTM Customer Service at service@astm.org. For *Annual Book of ASTM Standards* volume information, refer to the standard's Document Summary page on the ASTM website.

ASTM Test Methods

- E456 Terminology Relating to Quality and Statistics**
- E1309 Guide for Identification of Fiber-Reinforced Polymer-Matrix Composite Materials in Databases**
- E1434 Guide for Recording Mechanical Test Data of Fiber-Reinforced Composite Materials in Databases**

2.2 Military Standards:

- MIL-HDBK-17-3F Composite Materials Handbook, Volume 3—Polymer Matrix Composites Materials Usage, Design and Analysis³
- MIL-HDBK-728/1 Nondestructive Testing⁴
- MIL-HDBK-731A Nondestructive Testing Methods of Composite Materials—Thermography⁴
- MIL-HDBK-732A Nondestructive Testing Methods of Composite Materials—Acoustic Emission⁴
- MIL-HDBK-733A Nondestructive Testing Methods of Composite Materials—Radiography⁴
- MIL-HDBK-787A Nondestructive Testing Methods of Composite Materials—Ultrasonics⁴
- NASA Reference Publication 1092 Standard Tests for Toughened Resin Composites, Revised Edition, July 1983⁵**

3. Terminology

3.1 *Definitions*—Terminology **D3878** defines terms relating to composite materials. Terminology **D883** defines terms relating to plastics. Terminology **E6** defines terms relating to mechanical testing. Terminology **E456** and Practice **E177** define terms relating to statistics. In the event of a conflict between terms, Terminology **D3878** shall have precedence over the other standards.

3.2 *Definitions of Terms Specific to This Standard*—If the term represents a physical quantity, its analytical dimensions are stated immediately following the term (or letter symbol) in fundamental dimension form, using the following ASTM standard symbology for fundamental dimensions, shown within square brackets: $[M]$ for mass, $[L]$ for length, $[T]$ for time, $[\theta]$ for thermodynamic temperature, and $[nd]$ for non-dimensional quantities. Use of these symbols is restricted to analytical dimensions when used with square brackets, as the symbols may have other definitions when used without the brackets.

3.2.1 *nominal value, n*—a value, existing in name only, assigned to a measurable property for the purpose of convenient designation. Tolerances may be applied to a nominal value to define an acceptable range for the property.

3.2.2 *principal material coordinate system, n*—a coordinate system with axes that are normal to the planes of symmetry inherent to a material.

3.2.2.1 *Discussion*—Common usage, at least for Cartesian axes ($I23$, xyz , and so forth), generally assigns the coordinate system axes to the normal directions of planes of symmetry in

order that the highest property value in a normal direction (for elastic properties, the axis of greatest stiffness) would be I or x , and the lowest (if applicable) would be 3 or z . Anisotropic materials do not have a principal material coordinate system due to the total lack of symmetry, while, for isotropic materials, any coordinate system is a principal material coordinate system. In laminated composites, the principal material coordinate system has meaning only with respect to an individual orthotropic lamina. The related term for laminated composites is “reference coordinate system.”

3.2.3 *reference coordinate system, n*—a coordinate system for laminated composites used to define ply orientations. One of the reference coordinate system axes (normally the Cartesian x -axis) is designated the reference axis, assigned a position, and the ply principal axis of each ply in the laminate is referenced relative to the reference axis to define the ply orientation for that ply.

3.2.4 *specially orthotropic, adj*—a description of an orthotropic material as viewed in its principal material coordinate system. In laminated composites, a specially orthotropic laminate is a balanced and symmetric laminate of the $[0/90]_{ns}$ family as viewed from the reference coordinate system, such that the membrane-bending coupling terms of the laminate constitutive relation are zero.

3.3 Symbols:

- A = cross-sectional area of a specimen
- CV = coefficient of variation statistic of a sample population for a given property (in percent)
- D = damage diameter
- E^{CAI} = effective compressive modulus in the test direction
- F^{CAI} = ultimate compressive residual strength in the test direction
- h = specimen thickness
- l = specimen length
- n = number of specimens per sample population
- N = number of plies in laminate under test
- P_{max} = maximum force carried by test specimen prior to failure
- S_{n-1} = standard deviation statistic of a sample population for a given property
- w = specimen width
- x_i = test result for an individual specimen from the sample population for a given property
- \bar{x} = mean or average (estimate of mean) of a sample population for a given property

4. Summary of Test Method

4.1 A uniaxial compression test is performed using a balanced, symmetric laminated plate, which has been damaged and inspected prior to the application of compressive force. The damage state is imparted through out-of-plane loading caused by quasi-static indentation or drop-weight impact.

4.1.1 *Quasi-Static Indentation*—The rectangular plate is damaged due to application of an out-of-plane static indentation force in accordance with Test Method **D6264/D6264M**.

4.1.2 *Drop-Weight Impact*—The rectangular plate is damaged due to application of an out-of-plane drop-weight impact in accordance with Test Method **D7136/D7136M**.

³ Available from U.S. Army Research Laboratory, Materials Directorate, Aberdeen Proving Ground, MD 21001.

⁴ Available from U.S. Army Materials Technology Laboratory, Watertown, MA 02471.

⁵ Available from National Aeronautics and Space Administration (NASA)-Langley Research Center, Hampton, VA 23681-2199.

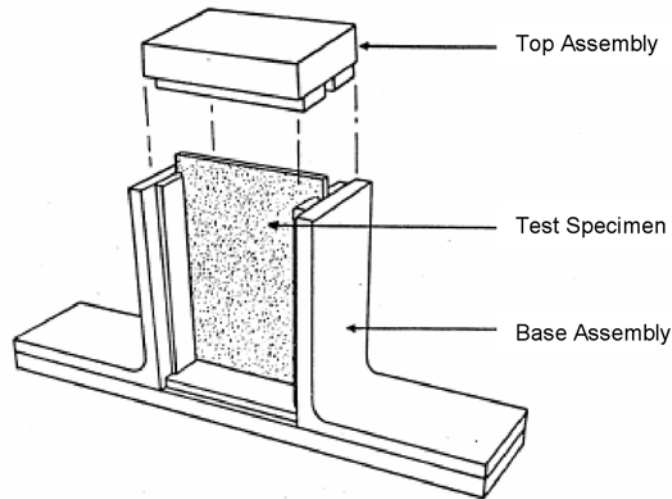
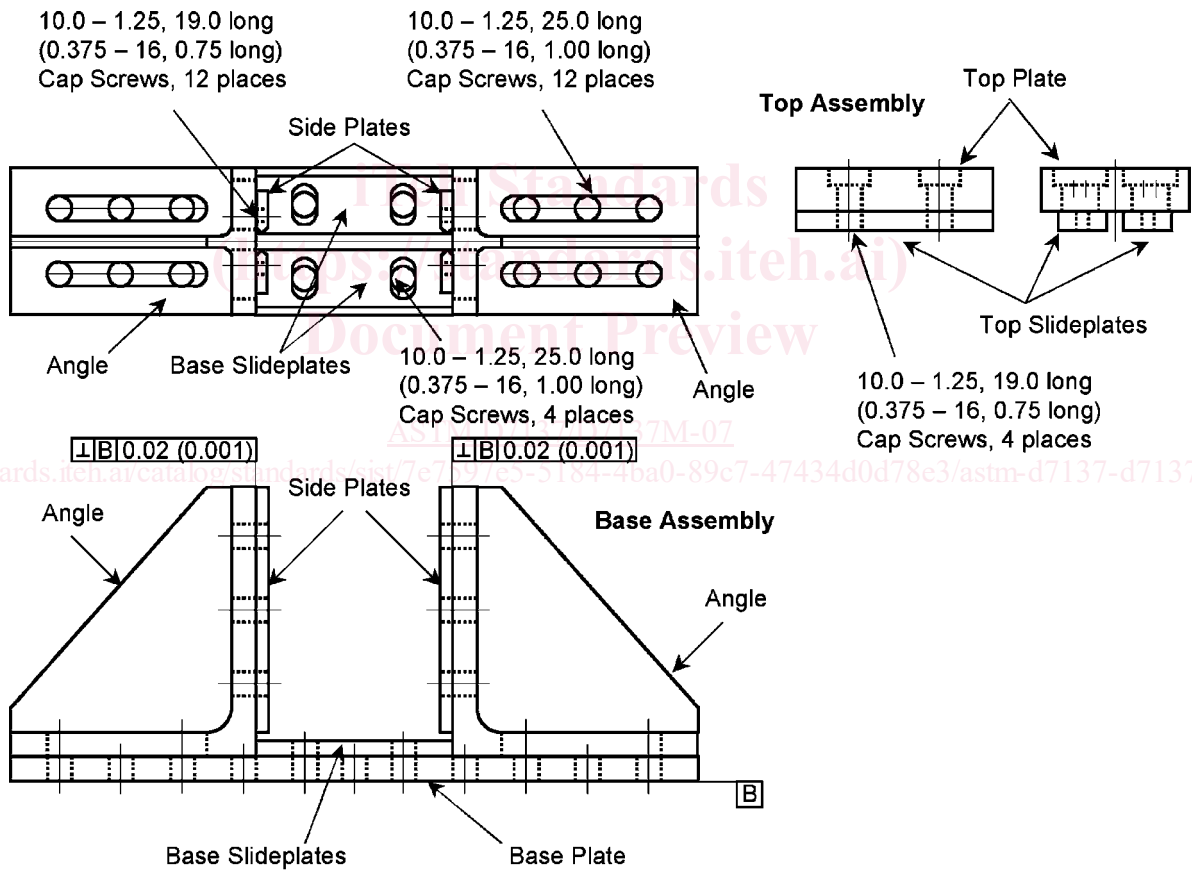

FIG. 1 Schematic of Compressive Residual Strength Support Fixture with Specimen in Place



Notes

- 1) All dimensions in millimeters (inches) unless otherwise specified.
- 2) Dimensional tolerances are linear ± 0.5 mm (± 0.02 in.), angular ± 0.5 degrees.
- 3) Break all edges.
- 4) Gussets on angles are optional but recommended.

FIG. 2 Support Fixture Assembly

4.2 The damaged plate is installed in a multi-piece support fixture, that has been aligned to minimize loading eccentricities and induced specimen bending. The specimen/fixture assembly

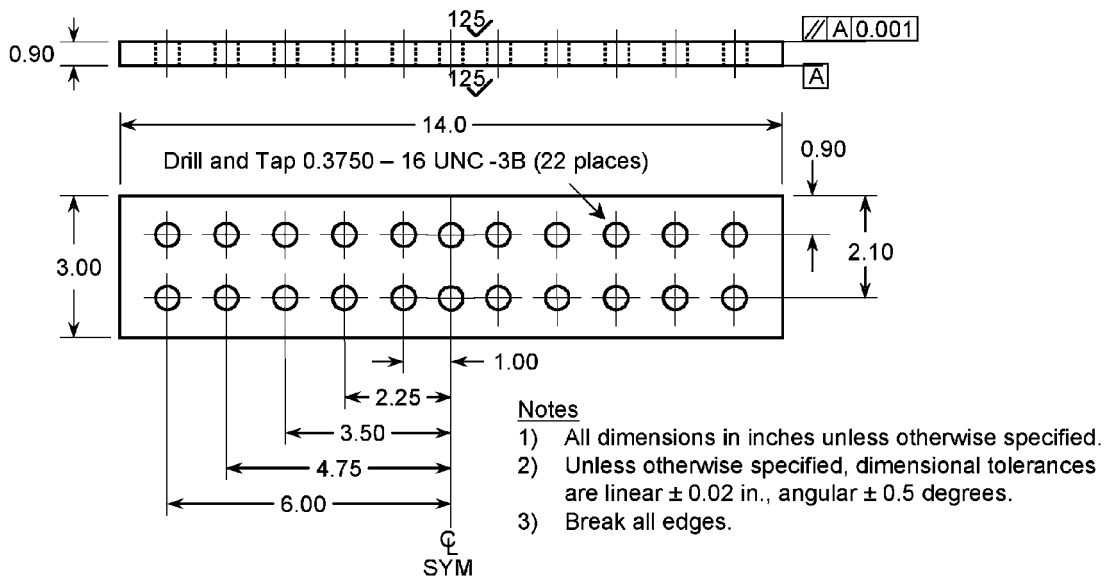

FIG. 3 Support Fixture Base Plate (Inch-Pound Version)

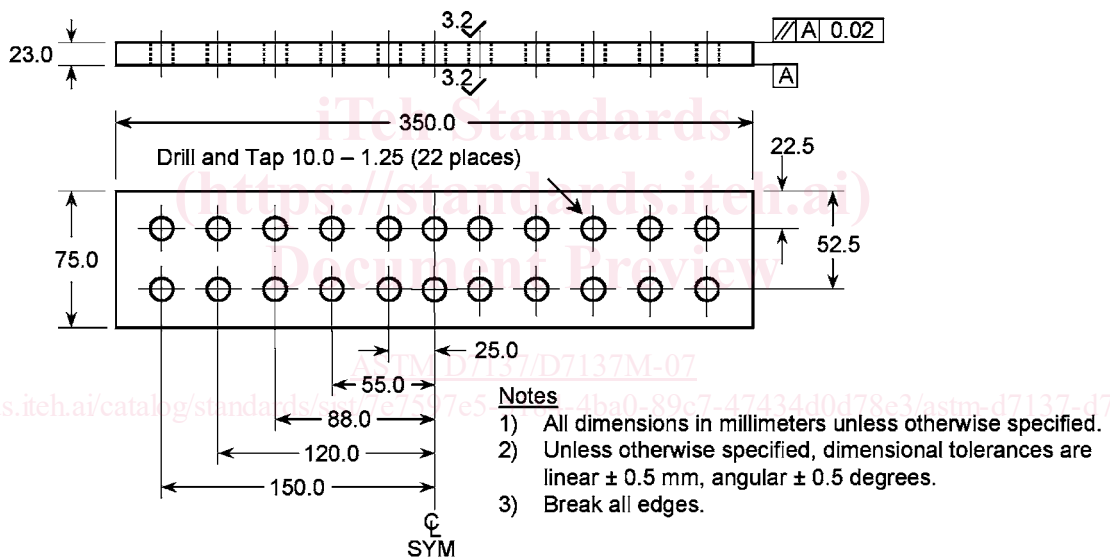

FIG. 4 Support Fixture Base Plate (SI Version)

is placed between flat platens and end-loaded under compressive force until failure. Applied force, crosshead displacement, and strain data are recorded while loading.

4.3 Preferred failure modes pass through the damage in the test specimen. However, acceptable failures may initiate away from the damage site, in instances when the damage produces a relatively low stress concentration or if the extent of damage is small, or both. Unacceptable failure modes are those related to load introduction by the support fixture, local edge support conditions, and specimen instability (unless the specimen is dimensionally representative of a particular structural application).

5. Significance and Use

5.1 Susceptibility to damage from concentrated out-of-plane forces is one of the major design concerns of many structures

made of advanced composite laminates. Knowledge of the damage resistance and damage tolerance properties of a laminated composite plate is useful for product development and material selection.

5.2 The residual strength data obtained using this test method is most commonly used in material specifications and research and development activities. The data are not intended for use in establishing design allowables, as the results are specific to the geometry and physical conditions tested and are generally not scalable to other configurations. Its usefulness in establishing quality assurance requirements is also limited, due to the inherent variability of induced damage, as well as the dependency of damage tolerance response upon the pre-existent damage state.

5.3 The properties obtained using this test method can provide guidance in regard to the anticipated damage tolerance

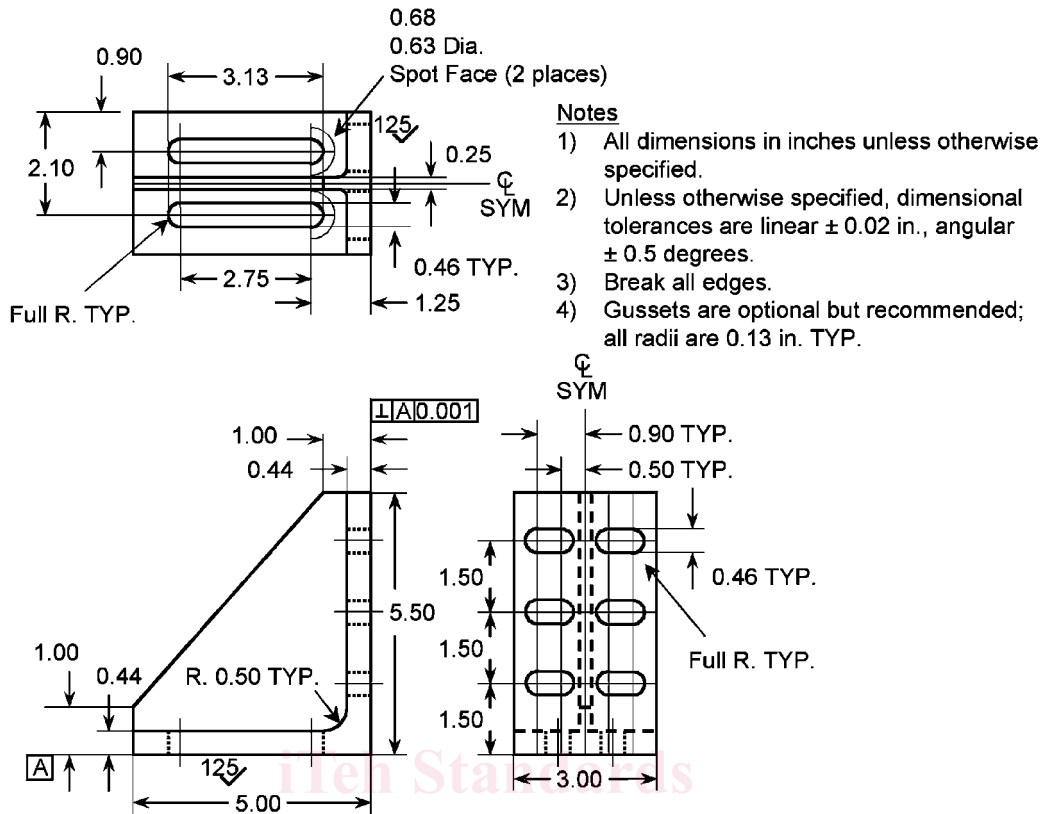

FIG. 5 Support Fixture Angles (Inch-Pound Version)

capability of composite structures of similar material, thickness, stacking sequence, and so forth. However, it must be understood that the damage tolerance of a composite structure is highly dependent upon several factors including geometry, stiffness, support conditions, and so forth. Significant differences in the relationships between the existent damage state and the residual compressive strength can result due to differences in these parameters. For example, residual strength and stiffness properties obtained using this test method would more likely reflect the damage tolerance characteristics of an un-stiffened monolithic skin or web than that of a skin attached to substructure which resists out-of-plane deformation. Similarly, test specimen properties would be expected to be similar to those of a panel with equivalent length and width dimensions, in comparison to those of a panel significantly larger than the test specimen.

5.4 The reporting section requires items that tend to influence residual compressive strength to be reported; these include the following: material, methods of material fabrication, accuracy of lay-up orientation, laminate stacking sequence and overall thickness, specimen geometry, specimen preparation, specimen conditioning, environment of testing, void content, volume percent reinforcement, type, size and location of damage (including method of non-destructive inspection), specimen/fixture alignment and gripping, time at temperature, and speed of testing.

5.5 Properties that result from the residual strength assessment include the following: compressive residual strength

F^{CAI} , compressive force as a function of crosshead displacement, and surface strains as functions of crosshead displacement.

6. Interferences

6.1 The response of a damaged specimen is dependent upon many factors, such as laminate thickness, ply thickness, stacking sequence, environment, damage type, damage geometry, damage location, and loading/support conditions. Consequently, comparisons cannot be made between materials unless identical test configurations, test conditions, and laminate configurations are used. Therefore, all deviations from the standard test configuration shall be reported in the results. Specific structural configurations and boundary conditions must be considered when applying the data generated using this test method to design applications.

6.2 *Material and Specimen Preparation*—Poor material fabrication practices, lack of control of fiber alignment, and damage induced by improper specimen machining are known causes of high material data scatter in composites in general. Important aspects of plate specimen preparation that contribute to data scatter include thickness variation, out-of-plane curvature, surface roughness, and failure to meet the dimensional and squareness tolerances (parallelism and perpendicularity) specified in 8.2.2.

6.3 *Damage Type*—Variations in the composite failure modes produced during the damaging event can contribute to strength, stiffness and strain data scatter.

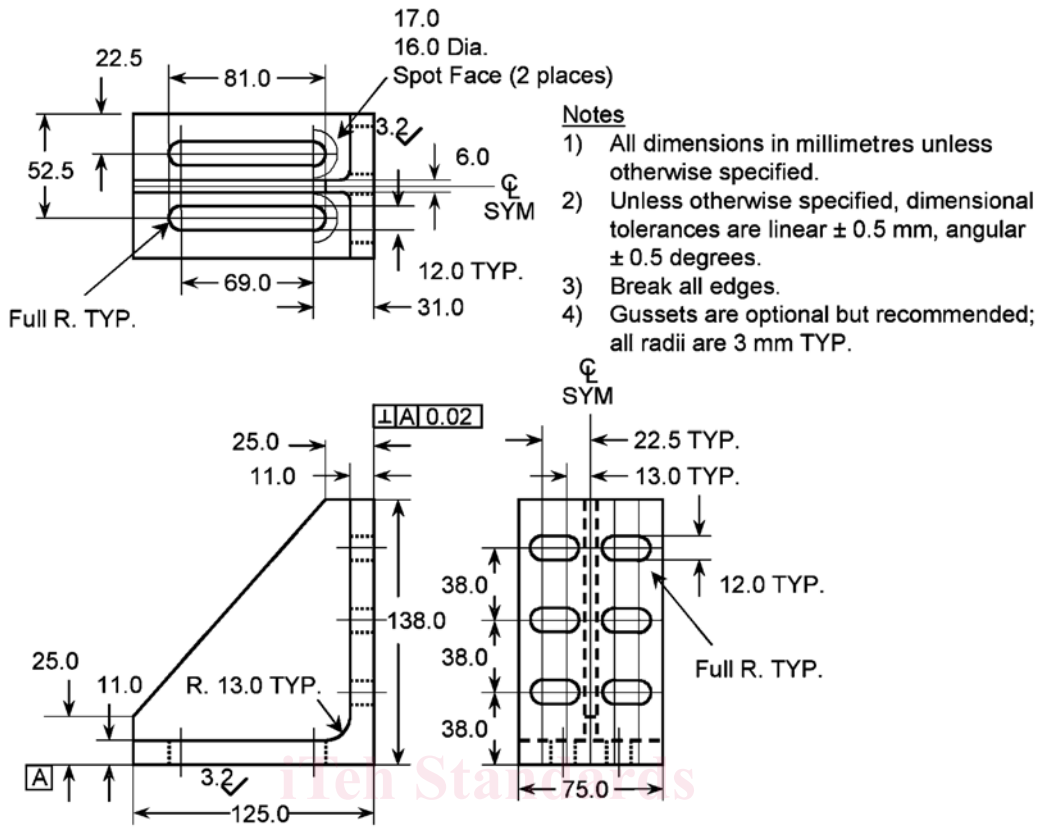

FIG. 6 Support Fixture Angles (SI Version)

Document Preview

https://standards.iteh.ai

https://standards.iteh.ai/catalog/standards/sist/597e5-5184-4ba0-97-47434d0d78e3/astm-d7137-d7137m-07

https://standards.iteh.ai/catalog/standards/sist/597e5-5184-4ba0-97-47434d0d78e3/astm-d7137-d7137m-07

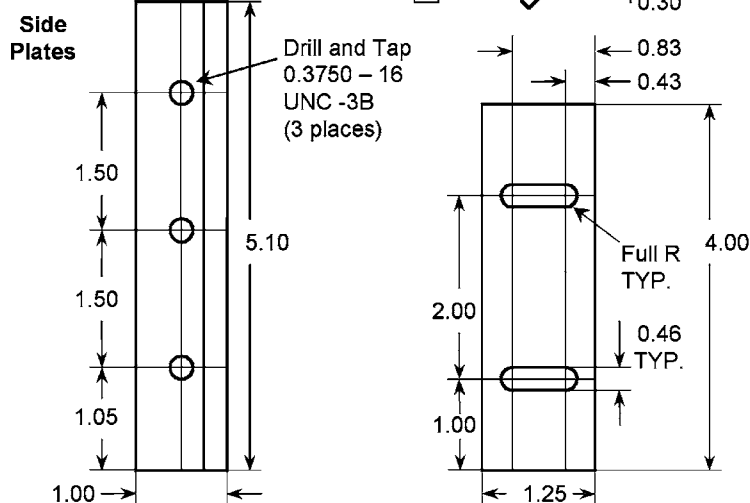

Notes

- 1) All dimensions in inches unless otherwise specified.
- 2) Dimensional tolerances are linear ± 0.02 in., angular ± 0.5 degrees.
- 3) Break all edges.

FIG. 7 Support Fixture Side Plates and Base Slideplates (Inch-Pound Version)