



**Intelligent Transport Systems (ITS);
Testing;
Conformance test specifications for
Cooperative Awareness Basic Service (CA);
Part 3: Abstract Test Suite (ATS) and
Protocol Implementation eXtra Information for Testing (PIXIT)**

PREVIEW
https://standards.itsrc.com/standards/sist/44455-868-3-v1.5.1-2020-04
460e-9c23-f5f10b5a199c

Reference

RTS/ITS-00190

Keywords

ATS, ITS, PIXIT, testing

ETSI

650 Route des Lucioles
F-06921 Sophia Antipolis Cedex - FRANCE

Tel.: +33 4 92 94 42 00 Fax: +33 4 93 65 47 16

Siret N° 348 623 562 00017 - NAF 742 C
Association à but non lucratif enregistrée à la
Sous-Préfecture de Grasse (06) N° 7803/88

Important notice

The present document can be downloaded from:

<http://www.etsi.org/standards-search>

The present document may be made available in electronic versions and/or in print. The content of any electronic and/or print versions of the present document shall not be modified without the prior written authorization of ETSI. In case of any existing or perceived difference in contents between such versions and/or in print, the prevailing version of an ETSI deliverable is the one made publicly available in PDF format at www.etsi.org/deliver.

Users of the present document should be aware that the document may be subject to revision or change of status.

Information on the current status of this and other ETSI documents is available at

<https://portal.etsi.org/TB/ETSIDeliverableStatus.aspx>

If you find errors in the present document, please send your comment to one of the following services:

<https://portal.etsi.org/People/CommiteeSupportStaff.aspx>

Copyright Notification

No part may be reproduced or utilized in any form or by any means, electronic or mechanical, including photocopying and microfilm except as authorized by written permission of ETSI.

The content of the PDF version shall not be modified without the written authorization of ETSI.

The copyright and the foregoing restriction extend to reproduction in all media.

© ETSI 2020.

All rights reserved.

DECT™, **PLUGTESTS™**, **UMTS™** and the ETSI logo are trademarks of ETSI registered for the benefit of its Members.

3GPP™ and **LTE™** are trademarks of ETSI registered for the benefit of its Members and of the 3GPP Organizational Partners.

oneM2M™ logo is a trademark of ETSI registered for the benefit of its Members and of the oneM2M Partners.

GSM® and the GSM logo are trademarks registered and owned by the GSM Association.

Contents

Intellectual Property Rights	5
Foreword.....	5
Modal verbs terminology.....	5
1 Scope	6
2 References	6
2.1 Normative references	6
2.2 Informative references.....	6
3 Definition of terms, symbols and abbreviations.....	7
3.1 Terms.....	7
3.2 Symbols.....	7
3.3 Abbreviations	7
4 Abstract Test Method (ATM).....	8
4.1 Abstract protocol tester	8
4.2 Test Configuration.....	8
4.3 Test architecture	9
4.4 Ports and ASPs (Abstract Services Primitives)	10
4.4.1 Introduction.....	10
4.4.2 Primitives of the camPort	10
4.4.3 Primitives of the utPort	10
4.5 Executing CA tests in secured mode	10
4.6 ETSI test adapter	11
5 Untestable Test Purposes.....	11
6 ATS conventions	11
6.1 Introduction	11
6.2 Testing conventions.....	11
6.2.1 Testing states	11
6.2.1.1 Initial state.....	11
6.2.1.2 Final state	11
6.2.2 Message types - ASN.1 definitions.....	12
6.3 Naming conventions.....	12
6.3.1 Introduction.....	12
6.3.2 General guidelines	12
6.3.3 ITS specific TTCN-3 naming conventions	13
6.3.4 Usage of Log statements.....	13
6.3.5 Test Case (TC) identifier	14
Annex A (normative): TTCN-3 library modules.....	15
A.1 Electronic annex, zip file with TTCN-3 code	15
Annex B (normative): Partial PIXIT pro forma for CA	16
B.1 Partial cancellation of copyright.....	16
B.2 Introduction	16
B.3 Identification summary.....	16
B.4 ATS summary	16
B.5 Test laboratory.....	17
B.6 Client identification.....	17
B.7 SUT	17
B.8 Protocol layer information.....	18

B.8.1	Protocol identification	18
B.8.2	IUT information	18
Annex C (normative): PCTR pro forma for CA		19
C.1	Partial cancellation of copyright.....	19
C.2	Introduction	19
C.3	Identification summary.....	19
C.3.1	Protocol conformance test report.....	19
C.3.2	IUT identification	19
C.3.3	Testing environment.....	20
C.3.4	Limits and reservation	20
C.3.5	Comments.....	20
C.4	IUT Conformance status	20
C.5	Static conformance summary	21
C.6	Dynamic conformance summary.....	21
C.7	Static conformance review report.....	21
C.8	Test campaign report	22
C.9	Observations.....	23
History	24

iTeh STANDARD PREVIEW
 (standards.iteh.ai)
 Full standard:
<https://standards.iteh.ai/catalog/standards/sist/44444583-e084-460e-9c23-f5f10fb861f9/etsi-ts-102-868-3-v1.5.1-2020-04>

Intellectual Property Rights

Essential patents

IPRs essential or potentially essential to normative deliverables may have been declared to ETSI. The information pertaining to these essential IPRs, if any, is publicly available for **ETSI members and non-members**, and can be found in ETSI SR 000 314: "*Intellectual Property Rights (IPRs); Essential, or potentially Essential, IPRs notified to ETSI in respect of ETSI standards*", which is available from the ETSI Secretariat. Latest updates are available on the ETSI Web server (<https://ipr.etsi.org/>).

Pursuant to the ETSI IPR Policy, no investigation, including IPR searches, has been carried out by ETSI. No guarantee can be given as to the existence of other IPRs not referenced in ETSI SR 000 314 (or the updates on the ETSI Web server) which are, or may be, or may become, essential to the present document.

Trademarks

The present document may include trademarks and/or tradenames which are asserted and/or registered by their owners. ETSI claims no ownership of these except for any which are indicated as being the property of ETSI, and conveys no right to use or reproduce any trademark and/or tradename. Mention of those trademarks in the present document does not constitute an endorsement by ETSI of products, services or organizations associated with those trademarks.

Foreword

This Technical Specification (TS) has been produced by ETSI Technical Committee Intelligent Transport Systems (ITS).

The present document is part 3 of a multi-part deliverable covering Conformance test specifications for Cooperative Awareness Basic Service (CA) as identified below:

- Part 1: "Test requirements and Protocol Implementation Conformance Statement (PICS) pro forma";
- Part 2: "Test Suite Structure and Test Purposes (TSS & TP)";
- Part 3: "Abstract Test Suite (ATS) and Protocol Implementation eXtra Information for Testing (PIXIT)".**

The development of ITS test specifications follows the guidance provided in ETSI EG 202 798 [i.1]. Therefore this ATS documentation is also based on the guidance provided in ETSI EG 202 798 [i.1].

Modal verbs terminology

In the present document "**shall**", "**shall not**", "**should**", "**should not**", "**may**", "**need not**", "**will**", "**will not**", "**can**" and "**cannot**" are to be interpreted as described in clause 3.2 of the [ETSI Drafting Rules](#) (Verbal forms for the expression of provisions).

"**must**" and "**must not**" are **NOT** allowed in ETSI deliverables except when used in direct citation.

1 Scope

The present document contains the Abstract Test Suite (ATS) for Cooperative Awareness Basic Service (CA) as defined in ETSI EN 302 637-2 [1] in compliance with the relevant requirements and in accordance with the relevant guidance given in ISO/IEC 9646-7 [i.7].

The objective of the present document is to provide a basis for conformance tests for Cooperative Awareness Basic Service (CA) equipment giving a high probability of interoperability between different manufacturers' equipment.

The ISO standards for the methodology of conformance testing (ISO/IEC 9646-1 [i.4] and ISO/IEC 9646-2 [i.5]) as well as the ETSI rules for conformance testing (ETSI ETS 300 406 [i.8]) are used as a basis for the test methodology.

2 References

2.1 Normative references

References are either specific (identified by date of publication and/or edition number or version number) or non-specific. For specific references, only the cited version applies. For non-specific references, the latest version of the referenced document (including any amendments) applies.

Referenced documents which are not found to be publicly available in the expected location might be found at <https://docbox.etsi.org/Reference/>.

NOTE: While any hyperlinks included in this clause were valid at the time of publication, ETSI cannot guarantee their long term validity.

The following referenced documents are necessary for the application of the present document.

- [1] ETSI EN 302 637-2 (V1.4.1): "Intelligent Transport Systems (ITS); Vehicular Communications; Basic Set of Applications; Part 2: Specification of Cooperative Awareness Basic Service".
- [2] ETSI TS 102 868-1 (V1.5.1): "Intelligent Transport Systems (ITS); Testing; Conformance test specifications for Cooperative Awareness Basic Service (CA); Part 1: Test requirements and Protocol Implementation Conformance Statement (PICS) pro forma".
- [3] ETSI TS 102 868-2 (V1.5.1): "Intelligent Transport Systems (ITS); Testing; Conformance test specifications for Cooperative Awareness Basic Service (CA); Part 2: Test Suite Structure and Test Purposes (TSS & TP)".
- [4] ETSI TS 102 894-2 (V1.3.1): "Intelligent Transport Systems (ITS); Users and applications requirements; Part 2: Applications and facilities layer common data dictionary".

2.2 Informative references

References are either specific (identified by date of publication and/or edition number or version number) or non-specific. For specific references, only the cited version applies. For non-specific references, the latest version of the referenced document (including any amendments) applies.

NOTE: While any hyperlinks included in this clause were valid at the time of publication, ETSI cannot guarantee their long term validity.

The following referenced documents are not necessary for the application of the present document but they assist the user with regard to a particular subject area.

- [i.1] ETSI EG 202 798 (V1.1.1): "Intelligent Transport Systems (ITS); Testing; Framework for conformance and interoperability testing".
- [i.2] ETSI TS 103 096-3 (V1.3.1): "Intelligent Transport Systems (ITS); Testing; Conformance test specifications for ITS Security; Part 3: Abstract Test Suite (ATS) and Protocol Implementation eXtra Information for Testing (PIXIT)".

- [i.3] ETSI TR 103 099 (V1.4.1): "Intelligent Transport Systems (ITS); Architecture of conformance validation framework".
- [i.4] ISO/IEC 9646-1 (1994): "Information technology -- Open Systems Interconnection -- Conformance testing methodology and framework -- Part 1: General concepts".
- [i.5] ISO/IEC 9646-2 (1994): "Information technology -- Open Systems Interconnection -- Conformance testing methodology and framework -- Part 2: Abstract Test Suite specification".
- [i.6] ISO/IEC 9646-6 (1994): "Information technology -- Open Systems Interconnection -- Conformance testing methodology and framework -- Part 6: Protocol profile test specification".
- [i.7] ISO/IEC 9646-7 (1995): "Information technology -- Open Systems Interconnection -- Conformance testing methodology and framework -- Part 7: Implementation Conformance Statements".
- [i.8] ETSI ETS 300 406 (1995): "Methods for testing and Specification (MTS); Protocol and profile conformance testing specifications; Standardization methodology".
- [i.9] ETSI ES 201 873-1 (V4.5.1): "Methods for Testing and Specification (MTS); The Testing and Test Control Notation version 3; Part 1: TTCN-3 Core Language".
- [i.10] ETSI ES 201 873-7 (V4.5.1): "Methods for Testing and Specification (MTS); The Testing and Test Control Notation version 3; Part 7: Using ASN.1 with TTCN-3".

3 Definition of terms, symbols and abbreviations

3.1 Terms

For the purposes of the present document, the terms given in ETSI EN 302 637-2 [1], ISO/IEC 9646-1 [i.4] and ISO/IEC 9646-7 [i.7] apply.

3.2 Symbols

Void.

3.3 Abbreviations

For the purposes of the present document, the following abbreviations apply:

ASN	Abstract Syntax Notation
ASN.1	Abstract Syntax Notation One
ATM	Abstract Test Method
ATS	Abstract Test Suite
BV	Valid test events for Behaviour tests
CA	Cooperative Awareness Basic Service
CAM	Cooperative Awareness Messages
CAN	Controller Area Network
CRS	Crash Status
FMT	Message Format
GFQ	Generation Frequency
GNSS	Global Navigation Satellite System
INA	Information Adaptation
ISO	International Organization for Standardization
ITS	Intelligent Transport Systems
IUT	Implementation Under Test
LDM	Local Dynamic Map
MSD	Message Dissemination
MSG	Message Generation

MSP	Message Processing
MTC	Main Test Component
PAR	Parameter
PCTR	Protocol Conformance Testing Report
PICS	Protocol Implementation Conformance Statement
PIXIT	Partial Protocol Implementation eXtra Information for Testing
PX	Pixit
SAP	Service Access Point
SCS	System Conformance Statement
SCTR	Static Conformance Test Report
SSP	Service Specific Permissions
SUT	System Under Test
TC	Test Case
TI	Timer tests
TP	Test Purposes
TS	Test System
TSS	Test Suite Structure
TTCN	Testing and Test Control Notation

4 Abstract Test Method (ATM)

4.1 Abstract protocol tester

The abstract protocol tester used by this test suite is described in figure 1. The test system will simulate valid and invalid protocol behaviour, and will analyse the reaction of the IUT.

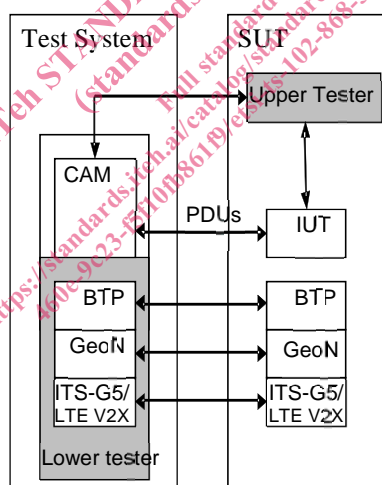

Figure 1: Abstract protocol tester - CA

4.2 Test Configuration

This test suite uses a unique test configuration in order to cover the different test scenarios. In this configuration, the tester simulates one ITS station implementing the CAM protocol.

4.3 Test architecture

The present document implements the general TTCN-3 test architecture described in ETSI EG 202 798 [i.1], clauses 6.3.2 and 8.3.1.

Figure 2 shows the test architecture used for the CA ATS. The CA test component requires using only the Main Test Component (MTC). The MTC communicates with the CA SUT over the camPort. The camPort is used to exchange CA protocol messages between the CA test component and the CA IUT.

The Upper tester entity in the SUT enables triggering CA functionalities by simulating primitives from application or LDM entities. It is required to trigger the CA layer in the SUT to send CA messages, which are resulting from upper layer primitives. Furthermore, receiving CA messages may result for the CA layer in sending primitives to the upper layer (sending Data to LDM for instance).

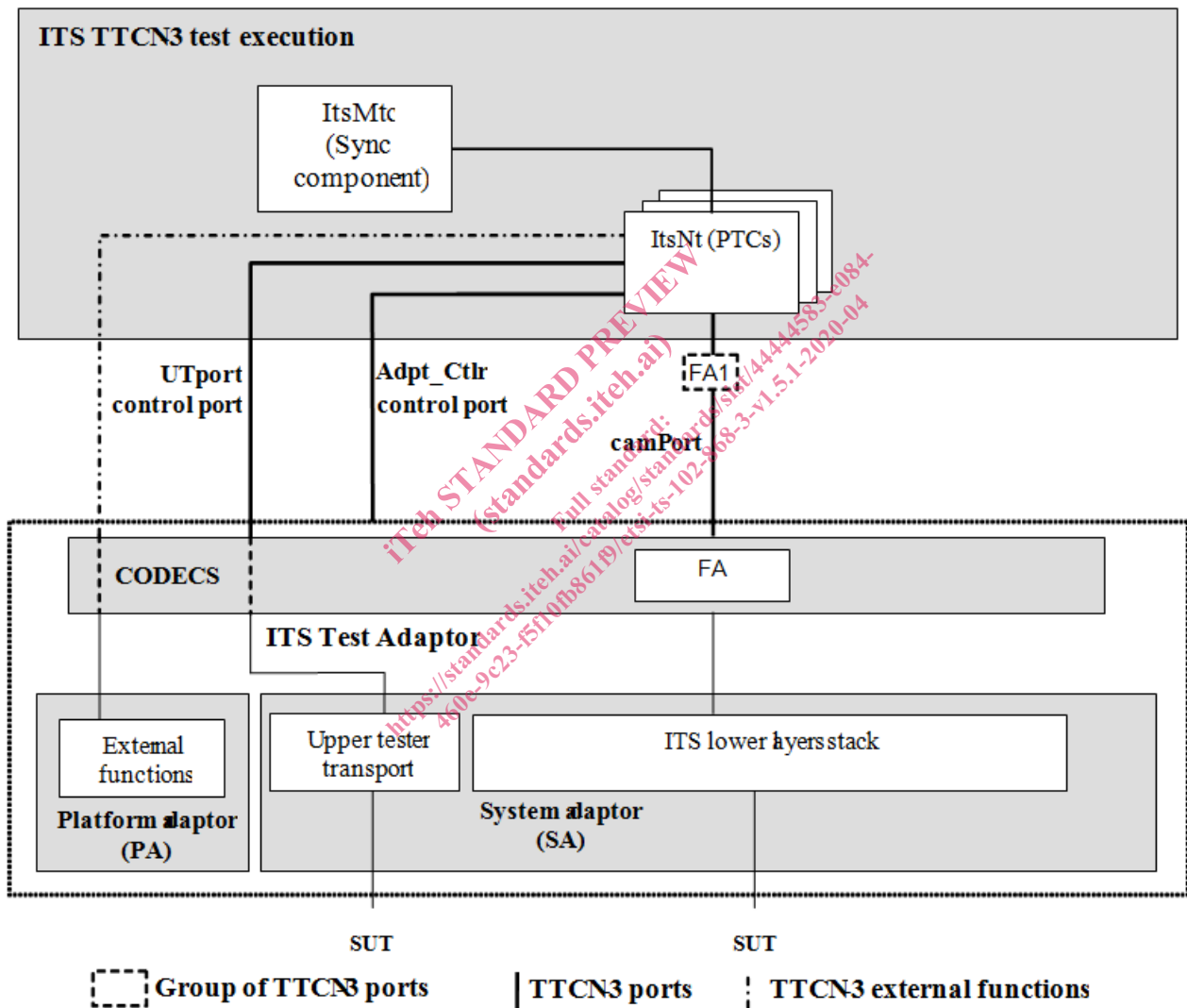

Figure 2: Test system architecture

4.4 Ports and ASPs (Abstract Services Primitives)

4.4.1 Introduction

Two ports are used by the CA ATS:

- The camPort, of type CamPort.
- The utPort, of type UpperTesterPort.

4.4.2 Primitives of the camPort

Two types of primitives are used in the camPort:

- The CamInd primitive used to receive messages of type CamPdu.
- The CamReq primitive used to send messages of type CamPdu.

These two primitives use the CamPdu type, which is declared in the CAM.asn ASN.1 module, following the ASN.1 definition from ETSI EN 302 637-2 [1].

```
CamPdu ::= SEQUENCE {
    header  ItsPduHeader,
    cam     CoopAwareness
}
```

4.4.3 Primitives of the utPort

This port uses two types of primitives:

- The UtInitialize primitive used to initialize IUT.
- The UtTrigger primitive used to trigger upper layer events in IUT.

4.5 Executing CA tests in secured mode

All the CA tests, with the exception of the SSP tests, can be executed with security enabled or with security disabled. The choice of running the CA tests in secured or non-secured mode has no impact on the result of the CA tests because the test verdicts assess CA protocol behaviour only.

The SSP tests can only be executed in secured mode.

The choice of running the CA tests in secured or non-secured mode shall be controlled via the test suite parameter PICS_IS_IUT_SECURED, see table A.5/1 of ETSI TS 102 868-1 [2].

Before running the CA tests in secured mode, the following steps need to be executed:

- security certificates need to be generated for the tester as well as for the IUT, see ETSI TS 103 096-3 [i.2], clause 5.3.2.5;
- security certificates need to be installed onto the IUT, see ETSI TS 103 096-3 [i.2], clause 5.3.2.6;
- in case of usage of the ETSI test adapter, the following test adapter parameters need to be configured.