



Designation: ~~D1632-06~~ Designation: D 1632 – 07

Standard Practice for Making and Curing Soil-Cement Compression and Flexure Test Specimens in the Laboratory¹

This standard is issued under the fixed designation D 1632; the number immediately following the designation indicates the year of original adoption or, in the case of revision, the year of last revision. A number in parentheses indicates the year of last reapproval. A superscript epsilon (ϵ) indicates an editorial change since the last revision or reapproval.

1. Scope*

1.1 This practice covers the procedure for making and curing compression and flexure test specimens of soil-cement in the laboratory under accurate control of quantities of materials and test conditions.

1-2

1.2 The values stated in SI units are to be regarded as the standard. The inch-pound equivalents are shown for information only.

1.3 This practice offers a set of instructions for performing one or more specific operations. This document cannot replace education or experience and should be used in conjunction with professional judgment. Not all aspects of this practice may be applicable in all circumstances. This ASTM standard is not intended to represent or replace the standard of care by which the adequacy of a given professional service must be judged, nor should this document be applied without consideration of a project's many unique aspects. The word "Standard" in the title of this document means only that the document has been approved through the ASTM consensus process.

1-3

1.4 This standard may involve hazardous materials, operations, and equipment. This standard does not purport to address all of the safety concerns, if any, associated with its use. It is the responsibility of the user of this standard to establish appropriate safety and health practices and determine the applicability of regulatory limitations prior to use.

2. Referenced Documents

2.1 ASTM Standards:²

C 127 Test Method for Density, Relative Density (Specific Gravity), and Absorption of Coarse Aggregate

C 617 Practice for Capping Cylindrical Concrete Specimens

D 558 Test Methods for Moisture-Density (Unit Weight) Relations of Soil-Cement Mixtures

D 559 Test Methods for Wetting and Drying Compacted Soil-Cement Mixtures

D 560 Test Methods for Freezing and Thawing Compacted Soil-Cement Mixtures

D 653 Terminology Relating to Soil, Rock, and Contained Fluids

D 1633 Test Methods for Compressive Strength of Molded Soil-Cement Cylinders

D 1634 Test Method for Compressive Strength of Soil-Cement Using Portions of Beams Broken in Flexure (Modified Cube Method)

D 1635 Test Method for Flexural Strength of Soil-Cement Using Simple Beam with Third-Point Loading

D 3740 Practice for Minimum Requirements for Agencies Engaged in the Testing and/or Inspection of Soil and Rock as Used in Engineering Design and Construction

D 4753 Guide for Evaluating, Selecting, and Specifying Balances and Standard Masses for Use in Soil, Rock, and Construction Materials Testing

D 6026 Practice for Using Significant Digits in Geotechnical Data

E 11 Specification for Wire Cloth and Sieves for Testing Purposes

3. Terminology

3.1 For common definitions of terms used in this standard refer to Terminology D 653.

¹ This practice is under the jurisdiction of ASTM Committee D18 on Soil and Rock and is the direct responsibility of Subcommittee D18.15 on Stabilization With Admixtures.

Current edition approved Nov. 1, 2006. Published January 2007. Originally approved in 1959. Last previous edition approved in 1996, which was withdrawn May 2005 and reinstated in November 2006.

Current edition approved Nov. 1, 2007. Published December 2007. Originally approved in 1959. Last previous edition approved in 2006 as D 1632 – 06.

² For referenced ASTM standards, visit the ASTM website, www.astm.org, or contact ASTM Customer Service at service@astm.org. For Annual Book of ASTM Standards volume information, refer to the standard's Document Summary page on the ASTM website.

*A Summary of Changes section appears at the end of this standard.

4. Significance and Use

3.1 This practice is used to prepare soil-cement specimens for compressive and flexural strength testing in accordance with Method B of Test Method D 1633, Test Method D 1634, and Test Method D 1635.

3.2 This practice does not apply to soil-cement specimens prepared in commonly available molds, which are 4.0 in. (101.6 mm) in diameter and 4.584 in. (116.4 mm) in height. For these size specimens, Methods D 559 or Methods D 560 should be used for sample preparation. Compressive strength testing should be in accordance with Method A of Test Method D 1633.

4.

4.3 This practice offers a set of instructions for performing one or more specific operations. This document cannot replace education or experience and should be used in conjunction with professional judgment. Not all aspects of this practice may be applicable in all circumstances. This ASTM standard is not intended to represent or replace the standard of care by which the adequacy of a given professional service must be judged, nor should this document be applied without consideration of a project's many unique aspects. The word "standard" in the title of this document means only that the document has been approved through the ASTM consensus process.

NOTE 1—The quality of the result produced by this standard is dependent on the competence of the personnel performing it, and the suitability of the equipment and facilities used. Agencies that meet the criteria of Practice D 3740 are generally considered capable of competent and objective testing/sampling/inspection/etc. Users of this standard are cautioned that compliance with Practice D 3740 does not in itself assure reliable results. Reliable results depend on many factors; Practice D 3740 provides a means of evaluating some of those factors.

5. Apparatus

4.1

5.1 *Compression Test Specimen Molds* —Molds (Fig. 1) having an inside diameter of 2.8 ± 0.01 in. (71 ± 0.25 mm) and a height of 9 in. (229 mm) for molding test specimens 2.8 in. (71 mm) in diameter and 5.6 in. (142 mm) high; machined steel top and bottom pistons having a diameter 0.005 in. (0.13 mm) less than the mold; a 6-in. (152-mm) long mold extension; and a spacer clip. At least two aluminum separating disks $\frac{1}{16}$ in. (1.54 mm) thick by 2.78 in. (70.6 mm) in diameter shall be provided.)

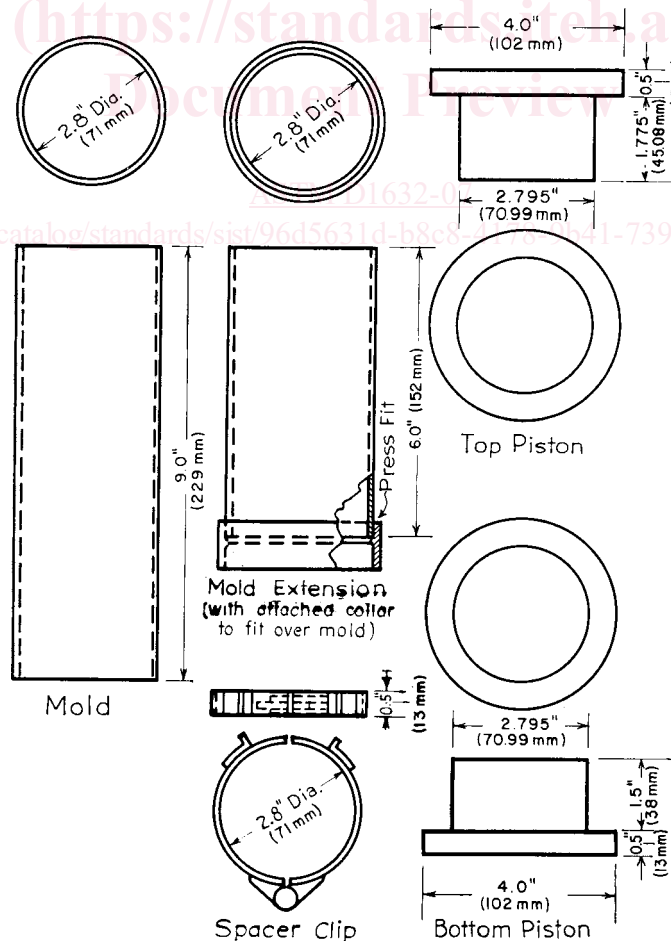

FIG. 1 Soil-Cement Cylinder Mold

an inside diameter of 71 ± 0.25 mm (2.8 ± 0.01 in.) and a height of 229 mm (9 in.) for molding test specimens 71 mm (2.8 in.) in diameter and 142 mm (5.6 in.) high; machined steel top and bottom pistons having a diameter 0.13 mm (0.005 in.) less than the mold; a 152-mm (6-in.) long mold extension; and a spacer clip. At least two aluminum separating disks 1.54 mm ($1/16$ in.) thick by 70.6 mm (2.78 in.) in diameter shall be provided.

NOTE 12—Satisfactory molds may be made from cold-drawn, seamless steel tubing having a Rockwell hardness of approximately 85 HRB or from steel pipe machined on the inside. The 2.871 by 5.6 -in. (71.42 -mm (2.8 by 142 -mm) 5.6 -in.) specimens fit many triaxial compression machines in service, and thus may be used for triaxial as well as unconfined compression tests.

4.25.2 *Flexure Test Specimen Molds*—Molds having inside dimensions of 3 by 3 by $11\frac{1}{4}$ in. (76.2 by 76.2 by 285.8 mm) (see —Molds having inside dimensions of 76.2 by 76.2 by 285.8 mm (3 by 3 by $11\frac{1}{4}$ in.) (see Fig. 2 and Fig. 3) for molding specimens of the same size. The molds shall be so designed that the specimen will be molded with its longitudinal axis in a horizontal position. The parts of the molds shall be tight-fitting and positively held together. The sides of the molds shall be sufficiently rigid to prevent spreading or warping, and shall be made of metal having a hardness not less than 85 HRB. The interior faces of the molds shall be plane surfaces with a permissible variation, in any 3-in. (76.2 -mm) 76.2 -mm (3-in.) line on a surface, of 0.002 -in. (0.051 mm) 0.051 mm (0.002 in.) for new molds and 0.003 -in. (0.076 mm) 0.076 mm (0.003 in.) for molds in use. The distance between opposite sides shall be 376.20 ± 0.01 -in. ($76.200.25$ mm (3 ± 0.25 mm) 0.01 in.) for new molds, and 376.20 ± 0.015 -in. ($76.200.38$ mm (3 ± 0.38 mm) 0.015 in.) for molds in use. The height of the molds shall be 3-in. (76.20 -mm) 76.20 mm (3 in.) with permissible variations of -0.01 -in. (-0.25 mm) and $+0.005$ -in. ($+0.13$ mm) of -0.25 mm (-0.01 in.) and $+0.13$ mm ($+0.005$ in.) for both new molds and for molds in use. Four 9.52 -mm ($3/8$ -in. (9.52 -mm) -in.) spacer bars and top and bottom machined steel plates shall be provided. The plates shall fit the mold with a 0.005 -in. (0.13 -mm) 0.13 mm (0.005-in.) clearance on all sides.

4.35.3 *Sieves*—2-in. (50-mm), $3/4$ -in. (19.0-mm), No. 4 (4.75-mm) and No. 16 (1.18-mm) sieves conforming to the requirements of Specification E11—50-mm (2-in.), 19.0-mm ($3/4$ -in.), 4.75-mm (No. 4) and 1.18-mm (No. 16) sieves conforming to the requirements of Specification E 11.

4.4

5.4 *Balances*—A balance or scale of 25-lb (12-kg) 12-kg (25-lb) capacity, sensitive to 0.01 lb (0.0045 kg) 0.0045 kg (0.01 lb) and a balance of 1000-g capacity, sensitive to 0.1 g, both meeting the requirements of Specification D 4753.

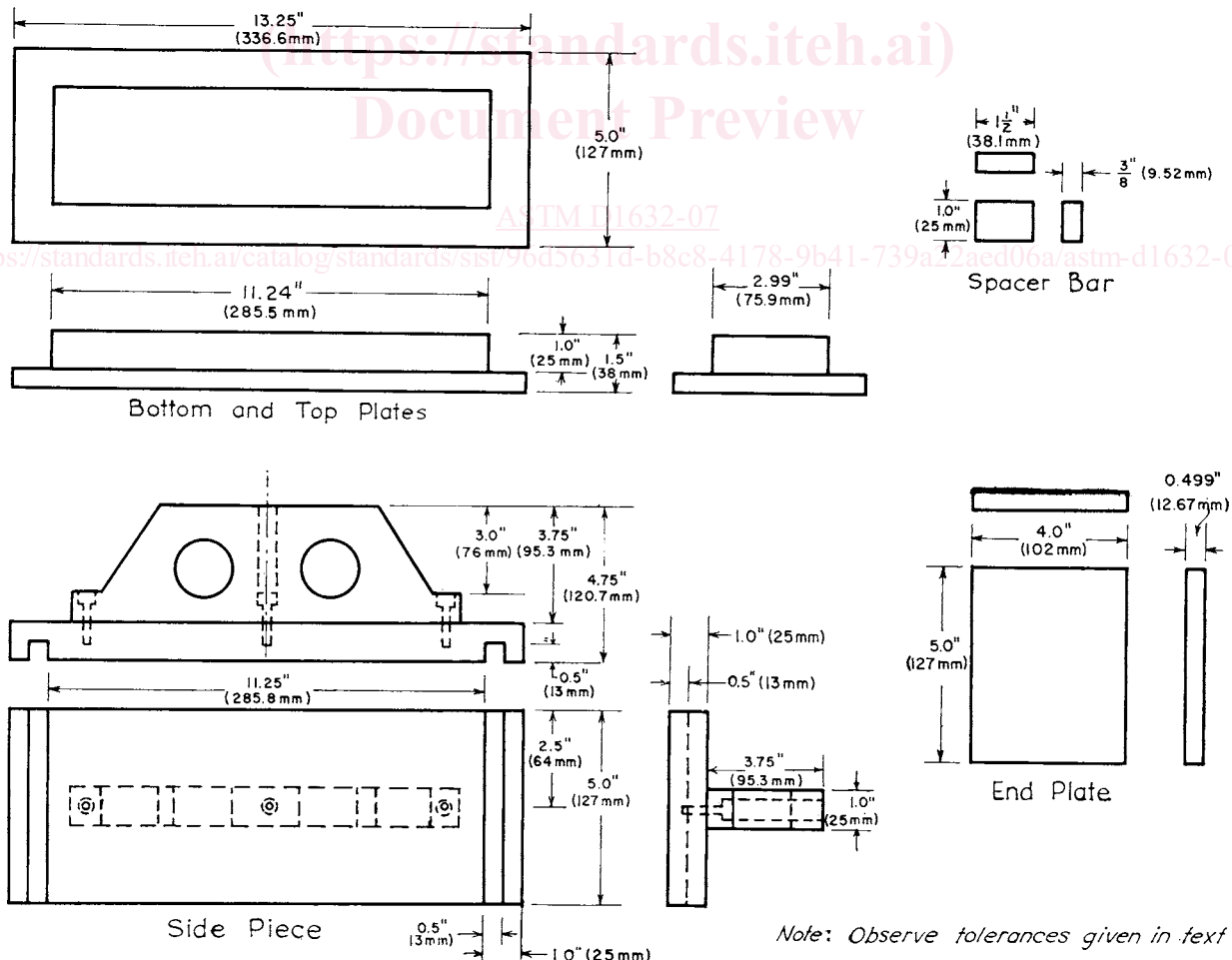

FIG. 2 Mold for Soil-Cement Beam for Flexure Test

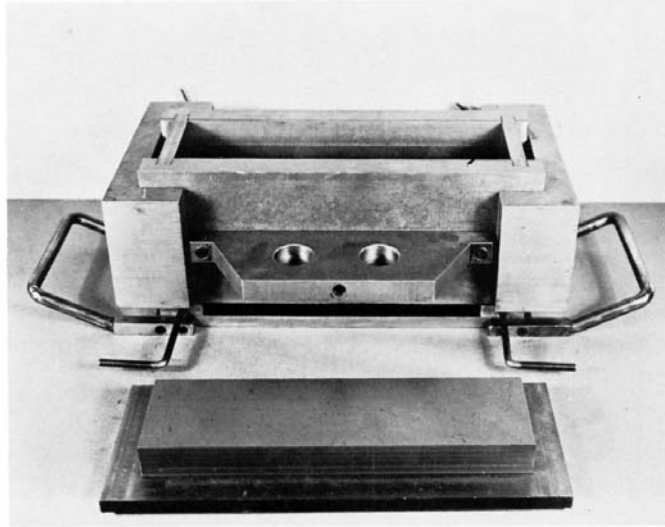

FIG. 3 Heavy Steel Mold and Top Plate for Making 3 by 3 by 11¼-in. (76.2 by 76.2 by 285.8-mm) Flexure Test Beam

4.5

5.5 Drying Oven—A thermostatically controlled drying oven capable of maintaining a temperature of $230 \pm 9^\circ\text{F}$ ($110 \pm 5^\circ\text{C}$) $110 \pm 5^\circ\text{C}$ ($230 \pm 9^\circ\text{F}$) for drying moisture samples.

4.65.6 Compression Testing Machine or Compression Frame, having a capacity of approximately ~~60000 lbf (267 kN)~~ 267 kN (60 000 lbf) for compacting flexural test specimens and for optional use in compacting compression test specimens.

4.75.7 Dropping-Weight Compacting Machine—A controlled dropping-weight device of ~~15 lb (6.8 kg)~~ 6.8 kg (15 lb) for striking the top piston, for optional use in compacting compression test specimens (see Fig. 4 and Fig. 5). When this equipment is used, the top piston listed in 4.15.1 is made the foot of the compacting device.

4.8

5.8 Compression Specimen Extruder, consisting of a piston, jack, and frame for extruding specimens from the mold.

4.9

5.9 Miscellaneous Equipment—Tools such as trowel, spatula, pan, and the like, or a suitable mechanical device for thoroughly mixing the sample of soil-cement with water; graduated cylinder for measuring water, moisture sample cans, and the like.

4.105.10 Tamping Rod—A square-end cut, $\frac{1}{2}$ -in. (12.7-mm) diameter, smooth steel rod approximately 20 in. (510 mm) in length:

4.11—A square-end cut, 12.7-mm ($\frac{1}{2}$ -in.) diameter, smooth steel rod approximately 510 mm (20 in.) in length.

5.11 Moist Room or Cabinet—A moist room or cabinet capable of maintaining a temperature of $73.4 \pm 3^\circ\text{F}$ ($23.0 \pm 1.7^\circ\text{C}$) 1.7°C ($73.4 \pm 3^\circ\text{F}$) and a relative humidity of not less than 96 % for moist curing specimens.

5.6. Preparation of Materials

5.1~~Bring~~6.1 Bring materials to room temperature (preferably ~~65~~ 18 to 75°F (18 to 24°C)) 75 $^\circ\text{F}$) before beginning the tests.

5.2~~Store~~6.2 Store cement in a dry place, in moisture-proof containers, preferably made of metal. Thoroughly mix the cement in order that the sample may be uniform throughout the tests. Pass it through a ~~No. 16 (1.18-mm)~~ 1.18-mm (No. 16) sieve and reject all lumps.

5.3~~The~~6.3 The mixing water shall be free of acids, alkalis, and oils, and in general suitable for drinking.

5.4~~6.4~~ Dry the soil sample, if damp when received from the field, until it becomes friable under a trowel. Drying may be in air or by use of drying apparatus such that the temperature of the sample does not exceed 140°F (60°C) 60 $^\circ\text{C}$ (140°F). Thoroughly break up the aggregations in such a manner as to avoid reducing the natural size of individual particles.

5.5~~6.5~~ Sieve an adequate quantity of representative pulverized soil on the ~~2-in. (50-mm)~~ 50-mm (2-in.), ~~19.0-mm ($\frac{3}{4}$ -in.) (19.0-mm)~~ 19.0-mm ($\frac{3}{4}$ -in.), and ~~No. 4 (4.75-mm)~~ 4.75-mm (No. 4) sieves. Discard any aggregate retained on the ~~2-in. (50-mm)~~ 50-mm (2-in.) sieve. Remove aggregate passing the ~~2-in. (50-mm)~~ 50-mm (2-in.) sieve and retained on the ~~19.0-mm ($\frac{3}{4}$ -in.) (19.0-mm)~~ 19.0-mm ($\frac{3}{4}$ -in.) sieve, and replace it with an equal mass of aggregate passing the ~~19.0-mm ($\frac{3}{4}$ -in.) (19.0-mm)~~ 19.0-mm ($\frac{3}{4}$ -in.) sieve and retained on the ~~No. 4 (4.75-mm)~~ 4.75-mm (No. 4) sieve. Obtain aggregate for replacement from the original sample.

NOTE 2—~~This 3—~~This practice for making soil-cement specimens for compression and flexure tests is used primarily with soil materials having not more than 35 % aggregate retained on the ~~No. 4 (4.75-mm)~~ 4.75-mm (No. 4) sieve and not more than 85 % retained on the ~~No. 40 (425- μm)~~ 425- μm (No. 40) sieve.