



Designation: D1632 – 07

Standard Practice for Making and Curing Soil-Cement Compression and Flexure Test Specimens in the Laboratory¹

This standard is issued under the fixed designation D1632; the number immediately following the designation indicates the year of original adoption or, in the case of revision, the year of last revision. A number in parentheses indicates the year of last reapproval. A superscript epsilon (ϵ) indicates an editorial change since the last revision or reapproval.

1. Scope*

1.1 This practice covers the procedure for making and curing compression and flexure test specimens of soil-cement in the laboratory under accurate control of quantities of materials and test conditions.

1.2 The values stated in SI units are to be regarded as the standard. The inch-pound equivalents are shown for information only.

1.3 *This practice offers a set of instructions for performing one or more specific operations. This document cannot replace education or experience and should be used in conjunction with professional judgment. Not all aspects of this practice may be applicable in all circumstances. This ASTM standard is not intended to represent or replace the standard of care by which the adequacy of a given professional service must be judged, nor should this document be applied without consideration of a project's many unique aspects. The word "Standard" in the title of this document means only that the document has been approved through the ASTM consensus process.*

1.4 *This standard may involve hazardous materials, operations, and equipment. This standard does not purport to address all of the safety concerns, if any, associated with its use. It is the responsibility of the user of this standard to establish appropriate safety and health practices and determine the applicability of regulatory limitations prior to use.*

2. Referenced Documents

2.1 ASTM Standards:²

- C127 Test Method for Density, Relative Density (Specific Gravity), and Absorption of Coarse Aggregate
- C617 Practice for Capping Cylindrical Concrete Specimens

¹ This practice is under the jurisdiction of ASTM Committee D18 on Soil and Rock and is the direct responsibility of Subcommittee D18.15 on Stabilization With Admixtures.

Current edition approved Nov. 1, 2007. Published December 2007. Originally approved in 1959. Last previous edition approved in 2006 as D1632 – 06. DOI: 10.1520/D1632-07.

² For referenced ASTM standards, visit the ASTM website, www.astm.org, or contact ASTM Customer Service at service@astm.org. For *Annual Book of ASTM Standards* volume information, refer to the standard's Document Summary page on the ASTM website.

- D558 Test Methods for Moisture-Density (Unit Weight) Relations of Soil-Cement Mixtures
- D559 Test Methods for Wetting and Drying Compacted Soil-Cement Mixtures (Withdrawn 2012)³
- D560 Test Methods for Freezing and Thawing Compacted Soil-Cement Mixtures (Withdrawn 2012)³
- D653 Terminology Relating to Soil, Rock, and Contained Fluids
- D1633 Test Methods for Compressive Strength of Molded Soil-Cement Cylinders
- D1634 Test Method for Compressive Strength of Soil-Cement Using Portions of Beams Broken in Flexure (Modified Cube Method)
- D1635 Test Method for Flexural Strength of Soil-Cement Using Simple Beam with Third-Point Loading
- D3740 Practice for Minimum Requirements for Agencies Engaged in Testing and/or Inspection of Soil and Rock as Used in Engineering Design and Construction
- D4753 Guide for Evaluating, Selecting, and Specifying Balances and Standard Masses for Use in Soil, Rock, and Construction Materials Testing
- D6026 Practice for Using Significant Digits in Geotechnical Data
- E11 Specification for Woven Wire Test Sieve Cloth and Test Sieves

3. Terminology

3.1 For common definitions of terms used in this standard refer to Terminology D653.

4. Significance and Use

4.1 This practice is used to prepare soil-cement specimens for compressive and flexural strength testing in accordance with Method B of Test Method D1633, Test Method D1634, and Test Method D1635.

4.2 This practice does not apply to soil-cement specimens prepared in commonly available molds, which are 4.0 in. (101.6 mm) in diameter and 4.584 in. (116.4 mm) in height. For these size specimens, Methods D559 or Methods D560

³ The last approved version of this historical standard is referenced on www.astm.org.

*A Summary of Changes section appears at the end of this standard

should be used for sample preparation. Compressive strength testing should be in accordance with Method A of Test Method D1633.

4.3 This practice offers a set of instructions for performing one or more specific operations. This document cannot replace education or experience and should be used in conjunction with professional judgment. Not all aspects of this practice may be applicable in all circumstances. This ASTM standard is not intended to represent or replace the standard of care by which the adequacy of a given professional service must be judged, nor should this document be applied without consideration of a project's many unique aspects. The word "standard" in the title of this document means only that the document has been approved through the ASTM consensus process.

NOTE 1—The quality of the result produced by this standard is dependent on the competence of the personnel performing it, and the suitability of the equipment and facilities used. Agencies that meet the criteria of Practice D3740 are generally considered capable of competent and objective testing/sampling/inspection/etc. Users of this standard are cautioned that compliance with Practice D3740 does not in itself assure reliable results. Reliable results depend on many factors; Practice D3740 provides a means of evaluating some of those factors.

5. Apparatus

5.1 Compression Test Specimen Molds —Molds (Fig. 1)

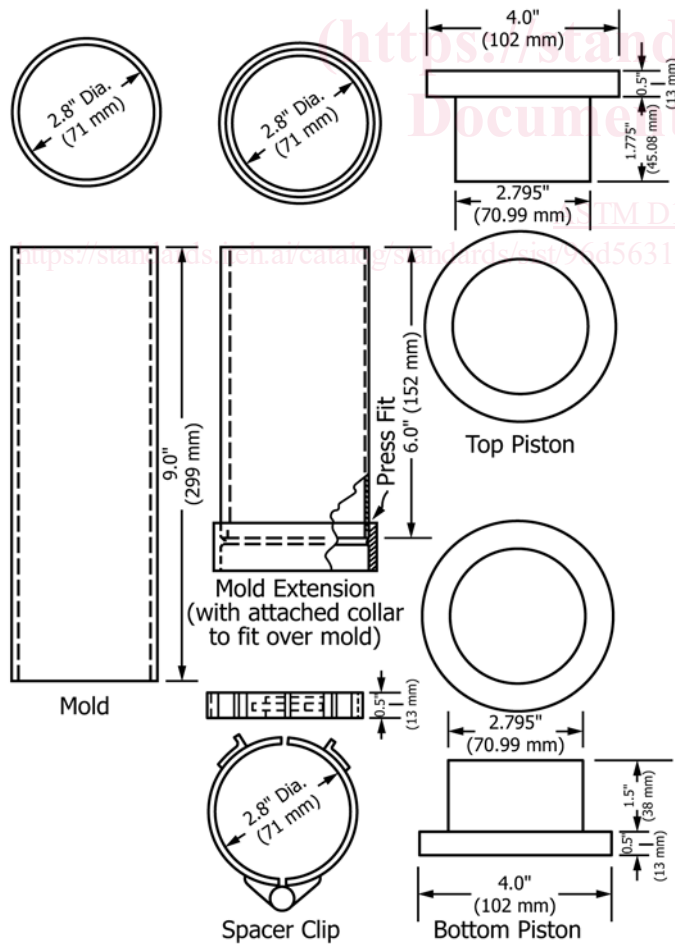

FIG. 1 Soil-Cement Cylinder Mold

having an inside diameter of 71 ± 0.25 mm (2.8 ± 0.01 in.) and a height of 229 mm (9 in.) for molding test specimens 71 mm (2.8 in.) in diameter and 142 mm (5.6 in.) high; machined steel top and bottom pistons having a diameter 0.13 mm (0.005 in.) less than the mold; a 152-mm (6-in.) long mold extension; and a spacer clip. At least two aluminum separating disks 1.54 mm ($1/16$ in.) thick by 70.6 mm (2.78 in.) in diameter shall be provided.

NOTE 2—Satisfactory molds may be made from cold-drawn, seamless steel tubing having a Rockwell hardness of approximately 85 HRB or from steel pipe machined on the inside. The 71 by 142-mm (2.8 by 5.6-in.) specimens fit many triaxial compression machines in service, and thus may be used for triaxial as well as unconfined compression tests.

5.2 Flexure Test Specimen Molds—Molds having inside dimensions of 76.2 by 76.2 by 285.8 mm (3 by 3 by 11¼ in.) (see Fig. 2 and Fig. 3) for molding specimens of the same size. The molds shall be so designed that the specimen will be molded with its longitudinal axis in a horizontal position. The parts of the molds shall be tight-fitting and positively held together. The sides of the molds shall be sufficiently rigid to prevent spreading or warping, and shall be made of metal having a hardness not less than 85 HRB. The interior faces of the molds shall be plane surfaces with a permissible variation, in any 76.2-mm (3-in.) line on a surface, of 0.051 mm (0.002 in.) for new molds and 0.076 mm (0.003 in.) for molds in use. The distance between opposite sides shall be 76.20 ± 0.25 mm (3 ± 0.01 in.) for new molds, and 76.20 ± 0.38 mm (3 ± 0.015 in.) for molds in use. The height of the molds shall be 76.20 mm (3 in.) with permissible variations of -0.25 mm (-0.01 in.) and $+0.13$ mm ($+0.005$ in.) for both new molds and for molds in use. Four 9.52-mm ($3/8$ -in.) spacer bars and top and bottom machined steel plates shall be provided. The plates shall fit the mold with a 0.13-mm (0.005-in.) clearance on all sides.

5.3 Sieves—50-mm (2-in.), 19.0-mm ($3/4$ -in.), 4.75-mm (No. 4) and 1.18-mm (No. 16) sieves conforming to the requirements of Specification E11.

5.4 Balances—A balance or scale of 12-kg (25-lb) capacity, sensitive to 0.0045 kg (0.01 lb) and a balance of 1000-g capacity, sensitive to 0.1 g, both meeting the requirements of Specification D4753.

5.5 Drying Oven—A thermostatically controlled drying oven capable of maintaining a temperature of $110 \pm 5^\circ\text{C}$ ($230 \pm 9^\circ\text{F}$) for drying moisture samples.

5.6 Compression Testing Machine or Compression Frame, having a capacity of approximately 267 kN (60 000 lbf) for compacting flexural test specimens and for optional use in compacting compression test specimens.

5.7 Dropping-Weight Compacting Machine—A controlled dropping-weight device of 6.8 kg (15 lb) for striking the top piston, for optional use in compacting compression test specimens (see Fig. 4 and Fig. 5). When this equipment is used, the top piston listed in 5.1 is made the foot of the compacting device.

5.8 Compression Specimen Extruder, consisting of a piston, jack, and frame for extruding specimens from the mold.

5.9 Miscellaneous Equipment—Tools such as trowel, spatula, pan, and the like, or a suitable mechanical device for

