

ETSI TS 123 285 V14.8.0 (2019-04)



**Universal Mobile Telecommunications System (UMTS);
LTE;
Architecture enhancements for V2X services
(3GPP TS 23.285 version 14.8.0 Release 14)**

Standard PREVIEW
Full document available at: <https://standards.iteh.ai/catalog/standards/sist/f2150e0f-7002-466d-b94e-78a184d3ae9a/etsi-ts-123-285-v14.8.0-2019-04>



ReferenceRTS/TSGS-0223285ve80

KeywordsLTE,UMTS

ETSI

650 Route des Lucioles
F-06921 Sophia Antipolis Cedex - FRANCE

Tel.: +33 4 92 94 42 00 Fax: +33 4 93 65 47 16

Siret N° 348 623 562 00017 - NAF 742 C
Association à but non lucratif enregistrée à la
Sous-Préfecture de Grasse (06) N° 7803/88

Important notice

The present document can be downloaded from:

<http://www.etsi.org/standards-search>

The present document may be made available in electronic versions and/or in print. The content of any electronic and/or print versions of the present document shall not be modified without the prior written authorization of ETSI. In case of any existing or perceived difference in contents between such versions and/or in print, the prevailing version of an ETSI deliverable is the one made publicly available in PDF format at www.etsi.org/deliver.

Users of the present document should be aware that the document may be subject to revision or change of status.

Information on the current status of this and other ETSI documents is available at

<https://portal.etsi.org/TB/ETSIDeliverableStatus.aspx>

If you find errors in the present document, please send your comment to one of the following services:

<https://portal.etsi.org/People/CommiteeSupportStaff.aspx>

Copyright Notification

No part may be reproduced or utilized in any form or by any means, electronic or mechanical, including photocopying and microfilm except as authorized by written permission of ETSI.

The content of the PDF version shall not be modified without the written authorization of ETSI.

The copyright and the foregoing restriction extend to reproduction in all media.

© ETSI 2019.

All rights reserved.

DECT™, **PLUGTESTS™**, **UMTS™** and the ETSI logo are trademarks of ETSI registered for the benefit of its Members.

3GPP™ and **LTE™** are trademarks of ETSI registered for the benefit of its Members and of the 3GPP Organizational Partners.

oneM2M™ logo is a trademark of ETSI registered for the benefit of its Members and of the oneM2M Partners.

GSM® and the GSM logo are trademarks registered and owned by the GSM Association.

Intellectual Property Rights

Essential patents

IPRs essential or potentially essential to normative deliverables may have been declared to ETSI. The information pertaining to these essential IPRs, if any, is publicly available for **ETSI members and non-members**, and can be found in ETSI SR 000 314: *"Intellectual Property Rights (IPRs); Essential, or potentially Essential, IPRs notified to ETSI in respect of ETSI standards"*, which is available from the ETSI Secretariat. Latest updates are available on the ETSI Web server (<https://ipr.etsi.org/>).

Pursuant to the ETSI IPR Policy, no investigation, including IPR searches, has been carried out by ETSI. No guarantee can be given as to the existence of other IPRs not referenced in ETSI SR 000 314 (or the updates on the ETSI Web server) which are, or may be, or may become, essential to the present document.

Trademarks

The present document may include trademarks and/or tradenames which are asserted and/or registered by their owners. ETSI claims no ownership of these except for any which are indicated as being the property of ETSI, and conveys no right to use or reproduce any trademark and/or tradename. Mention of those trademarks in the present document does not constitute an endorsement by ETSI of products, services or organizations associated with those trademarks.

Foreword

This Technical Specification (TS) has been produced by ETSI 3rd Generation Partnership Project (3GPP).

The present document may refer to technical specifications or reports using their 3GPP identities, UMTS identities or GSM identities. These should be interpreted as being references to the corresponding ETSI deliverables.

The cross reference between GSM, UMTS, 3GPP and ETSI identities can be found under <http://webapp.etsi.org/key/queryform.asp>.

Modal verbs terminology

In the present document "**shall**", "**shall not**", "**should**", "**should not**", "**may**", "**need not**", "**will**", "**will not**", "**can**" and "**cannot**" are to be interpreted as described in clause 3.2 of the [ETSI Drafting Rules](#) (Verbal forms for the expression of provisions).

"**must**" and "**must not**" are **NOT** allowed in ETSI deliverables except when used in direct citation.

Contents

Intellectual Property Rights	2
Foreword.....	2
Modal verbs terminology.....	2
Foreword.....	5
1 Scope	6
2 References	6
3 Definitions and abbreviations.....	7
3.1 Definitions	7
3.2 Abbreviations	8
4 Architecture model and concepts	8
4.1 General concept.....	8
4.2 Architectural reference model	8
4.2.1 PC5 and LTE-Uu based V2X architecture reference model.....	8
4.2.1.1 Non-roaming architecture for PC5 and LTE-Uu based V2X communication	8
4.2.1.2 Roaming architecture for PC5 and LTE-Uu based V2X communication	9
4.2.1.3 Inter-PLMN architecture for PC5 and LTE-Uu based V2X communication	10
4.2.2 MBMS for LTE-Uu based V2X architecture reference model	11
4.2.3 Reference points	12
4.3 Functional entities	13
4.3.1 V2X Control Function	13
4.3.1.1 General	13
4.3.1.2 V2X Control Function discovery	13
4.3.2 UE.....	13
4.3.3 V2X Application Server	13
4.3.4 MME.....	14
4.3.5 BM-SC.....	14
4.3.6 MBMS-GW	14
4.4 High level function.....	14
4.4.1 Authorization and Provisioning for V2X communications.....	14
4.4.1.1 Authorization and provisioning for V2X communications over PC5 reference point	14
4.4.1.1.1 General	14
4.4.1.1.2 Policy/Parameter provisioning	15
4.4.1.1.3 Principles for applying parameters for V2X communications over PC5 reference point.....	16
4.4.1.2 Authorization and provisioning for V2X communications over LTE-Uu reference point.....	17
4.4.1.2.1 General	17
4.4.1.2.2 Policy/Parameter provisioning	17
4.4.2 V2X message transmission/reception over PC5 reference point	17
4.4.3 V2X message transmission/reception over LTE-Uu reference point.....	18
4.4.3.1 General	18
4.4.3.2 V2X message transmission/reception via unicast	18
4.4.3.3 V2X message reception via MBMS.....	18
4.4.4 V2X Application Server discovery	19
4.4.4.1 General	19
4.4.4.2 Multiple V2X Application Server and Localized V2X Application Server discovery and routing	19
4.4.5 QoS handling for V2X communication	19
4.4.5.1 QoS handling for V2X communication over PC5 reference point.....	19
4.4.5.2 QoS handling for V2X communication over LTE-Uu reference point	20
4.4.6 Subscription to V2X services.....	20
4.4.7 MBMS bearer announcement for V2X use.....	21
4.4.7.1 General	21
4.4.7.2 User Service Description for V2X Communication (V2X USD)	21
4.4.7.3 User Service Description for V2X Application Server Discovery (V2X Server USD)	21
4.4.8 Support for V2X communication for UEs in limited service state	22
4.4.9 Charging support for V2X communication	22

4.4.9.1	Charging support for V2X communication over PC5 reference point	22
4.4.9.2	Charging support for V2X communication over LTE-Uu reference point	22
4.4.10	Security and privacy protection support for V2X communication	23
4.5	Identifiers	23
4.5.1	Identifiers for V2X communication over PC5 reference point	23
5	Functional description and information flows.....	23
5.1	Control and user plane stacks	23
5.1.1	User plane for PC5 reference point supporting V2X services	23
5.2	Service authorization and update for V2X communications	24
5.2.1	Service authorization procedures	24
5.2.2	Service authorization update procedures	24
5.3	Procedure for V2X communication over PC5 reference point	24
5.4	Procedure for V2X communication over LTE-Uu reference point	24
5.4.1	V2X Application Server discovery using MBMS	24
5.4.1.1	General	24
5.4.1.2	Procedures for receiving V2X Application Server information via MBMS	25
5.4.2	Procedure for V2X communication with MBMS	25
5.4.2.1	MBMS service area mapping	25
5.4.2.1.1	General	25
5.4.2.1.2	Functional Description	26
5.4.2.2	Local MBMS based MBMS data delivery	26
5.5	V2X impacts to EPC procedures	28
5.5.1	E-UTRAN attach procedure for UE	28
5.5.2	Service Request procedures for UE	28
5.5.3	S1 Handover procedures for UE	28
5.5.4	X2 Handover procedures for UE	28
5.5.5	Tracking Area Update procedure for UE	29
5.5.6	Insert Subscriber Data procedure for UE	29
5.5.7	Delete Subscriber Data procedure for UE	29
Annex A (informative):	Road Side Unit (RSU) implementation options.....	30
Annex B (informative):	Localized MBMS deployment options	31
B.1	General Description.....	31
B.2	Option of localized MBMS CN functions.....	31
B.3	Option of localized user plane of MBMS CN functions	32
Annex C (informative):	Example hybrid operation modes for V2X communication over PC5 and LTE-Uu	33
C.1	General	33
C.2	PC5 based V2X communication with MBMS reception	33
C.3	Simultaneous LTE-Uu based and PC5 based V2X communication without MBMS	33
Annex D (informative):	V2X Message Distribution Server deployment option	35
D.1	General Description.....	35
Annex E (informative):	Change history	36
History		37

Foreword

This Technical Report has been produced by the 3rd Generation Partnership Project (3GPP).

The contents of the present document are subject to continuing work within the TSG and may change following formal TSG approval. Should the TSG modify the contents of the present document, it will be re-released by the TSG with an identifying change of release date and an increase in version number as follows:

Version x.y.z

where:

- x the first digit:
 - 1 presented to TSG for information;
 - 2 presented to TSG for approval;
 - 3 or greater indicates TSG approved document under change control.
- y the second digit is incremented for all changes of substance, i.e. technical enhancements, corrections, updates, etc.
- z the third digit is incremented when editorial only changes have been incorporated in the document.

PREVIEW
iTech STANDARD
(standards.iteh.ai)
Full standard:
<https://standards.iteh.ai/catalog/standards/sist/f2b-dbe0f-7002-466d-b94e-78a184d3ae9a/etsi-ts-123-285-v14.8.0-2019-04>

1 Scope

The present document specifies architecture enhancements to facilitate vehicular communications for Vehicle-to-Everything (V2X) services, which includes Vehicle-to-Vehicle (V2V), Vehicle-to-Pedestrian (V2P), Vehicle-to-Infrastructure (V2I), and Vehicle-to-Network (V2N), according to the use cases and service requirements defined in TS 22.185 [2].

The following vehicular communications for V2X services are specified:

- V2X communication over PC5 reference point.
- V2X communication over LTE-Uu reference point.

2 References

The following documents contain provisions which, through reference in this text, constitute provisions of the present document.

- References are either specific (identified by date of publication, edition number, version number, etc.) or non-specific.
- For a specific reference, subsequent revisions do not apply.
- For a non-specific reference, the latest version applies. In the case of a reference to a 3GPP document (including a GSM document), a non-specific reference implicitly refers to the latest version of that document *in the same Release as the present document*.

- [1] 3GPP TR 21.905: "Vocabulary for 3GPP Specifications".
- [2] 3GPP TS 22.185: "Service requirements for V2X services".
- [3] ISO 17419:2018: "Intelligent transport systems - Cooperative systems - Globally unique identification".
- [4] IEEE Std 1609.12-2016: "[IEEE Standard for Wireless Access in Vehicular Environments \(WAVE\) - Identifier Allocations](#)".
- [5] 3GPP TS 23.303: "Proximity-based Services (ProSe); Stage 2".
- [6] 3GPP TS 23.401: "General Packet Radio Service (GPRS) enhancements for Evolved Universal Terrestrial Radio Access Network (E-UTRAN) access".
- [7] 3GPP TS 23.468: "Group Communication System Enablers for LTE (GCSE_LTE)".
- [8] 3GPP TS 23.246: "Multimedia Broadcast/Multicast Service (MBMS); Architecture and functional description".
- [9] 3GPP TS 36.331: "Evolved Universal Terrestrial Radio Access (E-UTRA); Radio Resource Control (RRC); Protocol specification".
- [10] 3GPP TS 36.300: "Evolved Universal Terrestrial Radio Access (E-UTRA) and Evolved Universal Terrestrial Radio Access Network (E-UTRAN); Overall description; Stage 2".
- [11] 3GPP TS 26.346: "Multimedia Broadcast/Multicast Service (MBMS); Protocols and codecs".
- [12] 3GPP TS 23.203: "Policy and charging control architecture".
- [13] IEEE Std 1609.3-2010: "IEEE Standard for Wireless Access in Vehicular Environments (WAVE) - Networking Services".
- [14] ISO 29281-1:2013: "Intelligent Transport Systems - Communications access for land mobiles (CALM) - Non-IP networking - Part 1: Fast networking & transport layer protocol (FNTP)".

- [15] 3GPP TS 29.272: "Evolved Packet System (EPS); Mobility Management Entity (MME) and Serving GPRS Support Node (SGSN) related interfaces based on Diameter protocol".
- [16] ETSI TS 102 637-2 V1.2.1: "Intelligent Transport Systems (ITS); Vehicular Communications; Basic Set of Applications; Part 2: Specification of Cooperative Awareness Basic Service".
- [17] ETSI TS 102 637-3 V1.1.1: "Intelligent Transport Systems (ITS); Vehicular Communications; Basic Set of Applications; Part 3: Specifications of Decentralized Environmental Notification Basic Service".
- [18] 3GPP TS 32.277: "Proximity-based Services (ProSe) charging".
- [19] Void.
- [20] 3GPP TS 32.251: "Telecommunication management; Charging management; Packet Switched (PS) domain charging".
- [21] 3GPP TS 32.273: "Telecommunication management; Charging management; Multimedia Broadcast and Multicast Service (MBMS) charging".
- [22] 3GPP TS 36.304: "Evolved Universal Terrestrial Radio Access (E-UTRA); User Equipment (UE) procedures in idle mode".
- [23] 3GPP TS 23.122: "Non-Access-Stratum (NAS) functions related to Mobile Station (MS) in idle mode".
- [24] Void.
- [25] 3GPP TS 33.185: "Security aspect for LTE support of V2X services".
- [26] 3GPP TS 36.321: "Evolved Universal Terrestrial Radio Access (E-UTRA); Medium Access Control (MAC) protocol specification".
- [27] 3GPP TS 24.386: "User Equipment (UE) to V2X control function; protocol aspects; Stage 3".

3 Definitions and abbreviations

3.1 Definitions

For the purposes of the present document, the terms and definitions given in TR 21.905 [1] and the following apply. A term defined in the present document takes precedence over the definition of the same term, if any, in TR 21.905 [1].

For the purposes of the present document, the following terms and definitions given in ISO 17419 [3] apply:

Intelligent Transport Systems

ITS Application Identifier

For the purposes of the present document, the following term and definition given in IEEE Std 1609.12-2016 [4] apply:

Provider Service Identifier

For the purposes of the present document, the following term and definition given in TS 22.185 [2] apply:

Road Side Unit

For the purposes of the present document, the following term and definition given in TS 23.303 [5] apply:

Geographical Area

3.2 Abbreviations

For the purposes of the present document, the abbreviations given in TR 21.905 [1] and the following apply. An abbreviation defined in the present document takes precedence over the definition of the same abbreviation, if any, in TR 21.905 [1].

C-TEID	Common-Tunnel Endpoint Identifier
ITS	Intelligent Transport Systems
ITS-AID	ITS Application Identifier
PSID	Provider Service Identifier
RSU	Road Side Unit
SIPTO@LN	SIPTO at the Local Network
USD	User Service Description
V2X	Vehicle-to-Everything

4 Architecture model and concepts

4.1 General concept

There are two modes of operation for V2X communication, namely over the PC5 and over LTE-Uu. LTE-Uu can be unicast and/or MBMS. These two operation modes may be used by a UE independently for transmission and reception, e.g. a UE can use MBMS for reception without using LTE-Uu for transmission. A UE may also receive V2X messages via LTE-Uu unicast downlink.

For both operation modes, the following principles apply:

- V2X Application Servers e.g. in different domains can communicate with each other for the exchange of V2X messages. The interface between V2X Application Servers and the methods of the exchange of messages between V2X Application Servers is out of scope of 3GPP.
- ProSe discovery feature (TS 23.303 [5] clause 5.3 ProSe Direct Discovery) is not required for V2X Services.

NOTE: ProSe discovery feature can be used by a V2X supporting UE, but that is up to UE implementation.

- Subject to regional regulations, lawful interception requirements apply to V2X Services.
- An RSU is not an architectural entity, but an implementation option. This is achieved by collocating a V2X application logic/server with some entities of the 3GPP system, as shown in examples in Annex A.

4.2 Architectural reference model

4.2.1 PC5 and LTE-Uu based V2X architecture reference model

4.2.1.1 Non-roaming architecture for PC5 and LTE-Uu based V2X communication

Figure 4.2.1.1-1 shows the high level view of the non-roaming architecture for PC5 and LTE-Uu based V2X communication.

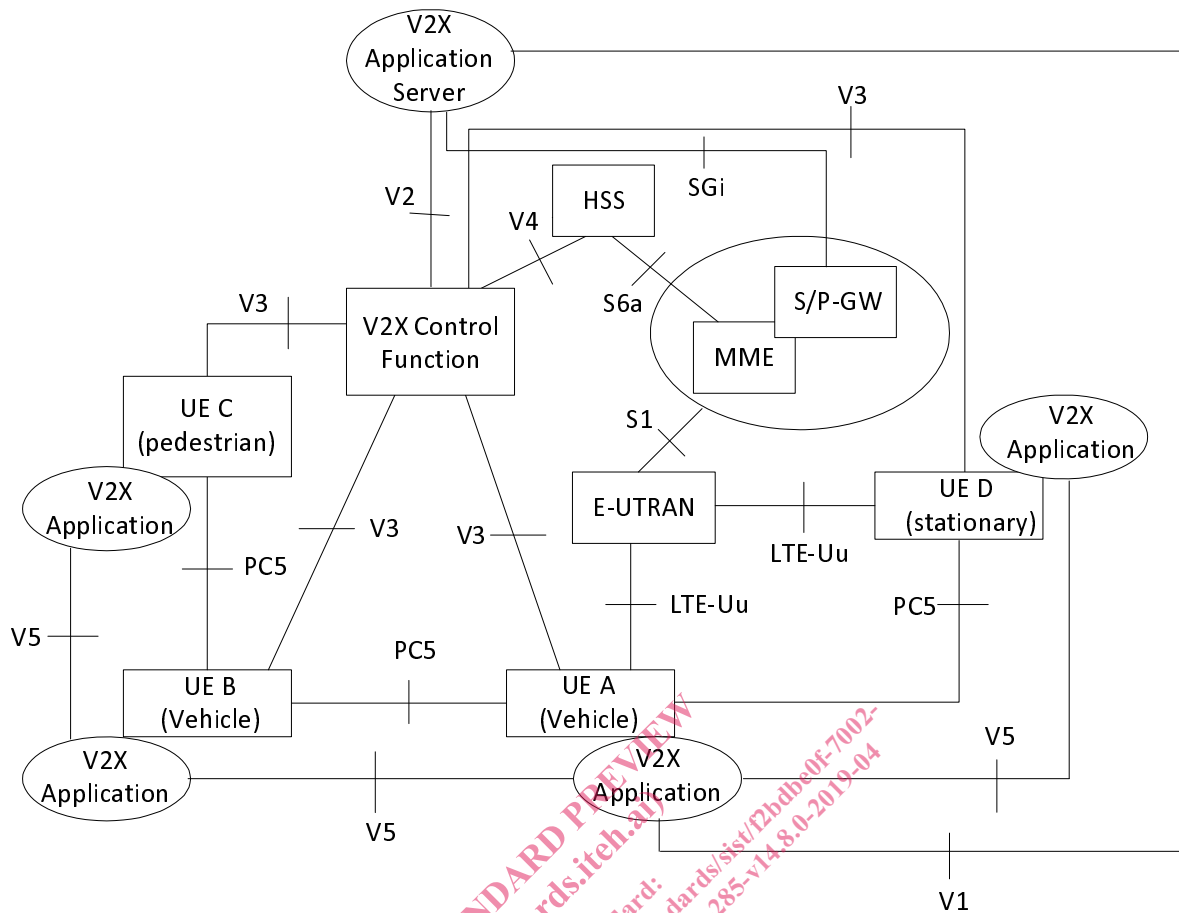

Figure 4.2.1.1-1: Non-roaming reference architecture for PC5 and LTE-Uu based V2X communication

4.2.1.2 Roaming architecture for PC5 and LTE-Uu based V2X communication

Figure 4.2.1.2-1 shows the high level view of the roaming architecture for PC5 and LTE-Uu based V2X communication. In this figure, UE A uses a subscription of PLMN A and UE B uses a subscription of PLMN B; UE A is roaming in PLMN B while UE B is not roaming.

A V2X Application Server may connect to multiple PLMNs, e.g. one V2X Application Server can connect with the V2X Control Function in PLMN A and the V2X Control Function in PLMN B in the figure.

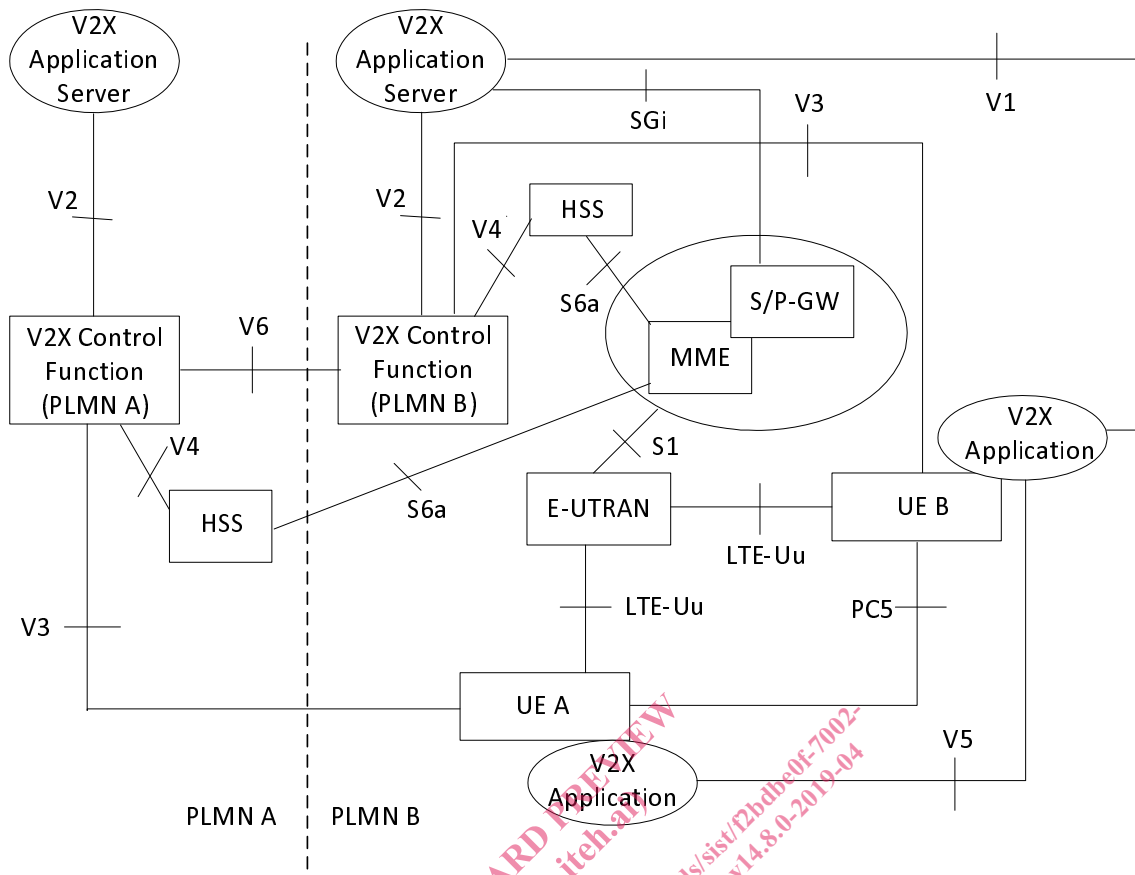

Figure 4.2.1.2-1: Roaming reference architecture for PC5 and LTE-Uu based V2X communication

4.2.1.3 Inter-PLMN architecture for PC5 and LTE-Uu based V2X communication

Figure 4.2.1.3-1 shows the high level view of the inter-PLMN architecture for PC5 and LTE-Uu based V2X communication. In this figure, UE A uses a subscription of PLMN A and UE B uses a subscription of PLMN B; UE A is roaming in PLMN C while UE B is not roaming.