



**Digital cellular telecommunications system (Phase 2+) (GSM);  
Universal Mobile Telecommunications System (UMTS);  
LTE;  
Architecture enhancements to facilitate communications with  
packet data networks and applications  
(3GPP TS 23.682 version 15.8.0 Release 15)**



---

**Reference**

RTS/TSGS-0223682vf80

---

**Keywords**

GSM,LTE,UMTS

**ETSI**

650 Route des Lucioles  
F-06921 Sophia Antipolis Cedex - FRANCE

Tel.: +33 4 92 94 42 00 Fax: +33 4 93 65 47 16

Siret N° 348 623 562 00017 - NAF 742 C  
Association à but non lucratif enregistrée à la  
Sous-Préfecture de Grasse (06) N° 7803/88

---

**Important notice**

The present document can be downloaded from:  
<http://www.etsi.org/standards-search>

The present document may be made available in electronic versions and/or in print. The content of any electronic and/or print versions of the present document shall not be modified without the prior written authorization of ETSI. In case of any existing or perceived difference in contents between such versions and/or in print, the prevailing version of an ETSI deliverable is the one made publicly available in PDF format at [www.etsi.org/deliver](http://www.etsi.org/deliver).

Users of the present document should be aware that the document may be subject to revision or change of status. Information on the current status of this and other ETSI documents is available at <https://portal.etsi.org/TB/ETSIDeliverableStatus.aspx>

If you find errors in the present document, please send your comment to one of the following services:  
<https://portal.etsi.org/People/CommiteeSupportStaff.aspx>

---

**Copyright Notification**

No part may be reproduced or utilized in any form or by any means, electronic or mechanical, including photocopying and microfilm except as authorized by written permission of ETSI.

The content of the PDF version shall not be modified without the written authorization of ETSI.

The copyright and the foregoing restriction extend to reproduction in all media.

© ETSI 2019.  
All rights reserved.

**DECT™**, **PLUGTESTS™**, **UMTS™** and the ETSI logo are trademarks of ETSI registered for the benefit of its Members. **3GPP™** and **LTE™** are trademarks of ETSI registered for the benefit of its Members and of the 3GPP Organizational Partners.

**oneM2M™** logo is a trademark of ETSI registered for the benefit of its Members and of the oneM2M Partners.

**GSM®** and the GSM logo are trademarks registered and owned by the GSM Association.

---

# Intellectual Property Rights

## Essential patents

IPRs essential or potentially essential to normative deliverables may have been declared to ETSI. The information pertaining to these essential IPRs, if any, is publicly available for **ETSI members and non-members**, and can be found in ETSI SR 000 314: *"Intellectual Property Rights (IPRs); Essential, or potentially Essential, IPRs notified to ETSI in respect of ETSI standards"*, which is available from the ETSI Secretariat. Latest updates are available on the ETSI Web server (<https://ipr.etsi.org/>).

Pursuant to the ETSI IPR Policy, no investigation, including IPR searches, has been carried out by ETSI. No guarantee can be given as to the existence of other IPRs not referenced in ETSI SR 000 314 (or the updates on the ETSI Web server) which are, or may be, or may become, essential to the present document.

## Trademarks

The present document may include trademarks and/or tradenames which are asserted and/or registered by their owners. ETSI claims no ownership of these except for any which are indicated as being the property of ETSI, and conveys no right to use or reproduce any trademark and/or tradename. Mention of those trademarks in the present document does not constitute an endorsement by ETSI of products, services or organizations associated with those trademarks.

---

# Foreword

This Technical Specification (TS) has been produced by ETSI 3rd Generation Partnership Project (3GPP).

The present document may refer to technical specifications or reports using their 3GPP identities, UMTS identities or GSM identities. These should be interpreted as being references to the corresponding ETSI deliverables.

The cross reference between GSM, UMTS, 3GPP and ETSI identities can be found under <http://webapp.etsi.org/key/queryform.asp>.

---

# Modal verbs terminology

In the present document **"shall"**, **"shall not"**, **"should"**, **"should not"**, **"may"**, **"need not"**, **"will"**, **"will not"**, **"can"** and **"cannot"** are to be interpreted as described in clause 3.2 of the [ETSI Drafting Rules](#) (Verbal forms for the expression of provisions).

**"must"** and **"must not"** are **NOT** allowed in ETSI deliverables except when used in direct citation.

# Contents

Intellectual Property Rights .....	2
Foreword.....	2
Modal verbs terminology.....	2
Foreword.....	7
1 Scope .....	8
2 References .....	8
3 Definitions and abbreviations.....	10
3.1 Definitions .....	10
3.2 Abbreviations .....	10
4 Architecture Model and Concepts.....	10
4.1 General Concept .....	10
4.2 Architectural Reference Model .....	11
4.3 Reference points .....	16
4.3.1 General.....	16
4.3.2 List of Reference Points.....	16
4.3.3 Reference Point Requirements.....	17
4.3.3.1 Tsp Reference Point Requirements .....	17
4.3.3.2 T4 Reference Point Requirements.....	17
4.3.3.3 Void.....	17
4.3.3.4 S6m Reference Point Requirements.....	17
4.3.3.5 S6n Reference Point Requirements.....	18
4.3.3.6 T6a/T6b Reference Point Requirements.....	18
4.3.3.7 S6t Reference Point Requirements.....	18
4.3.3.8 T6ai/T6bi Reference Point Requirements.....	18
4.3.3.9 T7 Reference Point Requirements.....	18
4.3.3.10 Ns Reference Point Requirements.....	19
4.3.3.11 Nu Reference Point Requirements.....	19
4.3.3.12 T8 Reference Point Requirements.....	19
4.4 Network Elements .....	19
4.4.1 General.....	19
4.4.2 MTC-IWF.....	19
4.4.3 HSS/HLR.....	20
4.4.4 GGSN/P-GW .....	21
4.4.5 SGSN/MME/MSR.....	21
4.4.7 MTC AAA .....	22
4.4.8 Service Capability Exposure Function.....	22
4.4.9 Interworking SCEF.....	24
4.4.10 RAN Congestion Awareness Function .....	24
4.4.11 Packet Flow Description Function.....	24
4.5 High Level Function.....	25
4.5.1 Device Triggering Function .....	25
4.5.2 PS-only Service Provision .....	25
4.5.3 Core Network assisted RAN parameters tuning .....	25
4.5.4 UE Power Saving Mode .....	25
4.5.5 Group Message Delivery .....	27
4.5.6 Monitoring Events .....	27
4.5.6.1 General .....	27
4.5.6.2 Monitoring Events via HSS and MME/SGSN .....	28
4.5.6.3 Monitoring Events via PCRF .....	28
4.5.6.4 Void.....	28
4.5.7 High latency communication .....	29
4.5.8 Support of informing about potential network issues .....	29
4.5.9 Resource management of background data transfer .....	29
4.5.10 E-UTRAN network resource optimizations based on communication patterns provided to the MME.....	30

4.5.11	Support of setting up an AS session with required QoS .....	30
4.5.12	Change the chargeable party at session set-up or during the session .....	31
4.5.13	Extended idle mode DRX .....	31
4.5.13.1	General .....	31
4.5.13.2	Paging for extended idle mode DRX in UTRAN .....	32
4.5.13.3	Paging for extended idle mode DRX in E-UTRAN .....	33
4.5.13.3.0	General .....	33
4.5.13.3.1	Hyper SFN, Paging Hyperframe and Paging Time Window length .....	33
4.5.13.3.2	Loose Hyper SFN synchronization .....	33
4.5.13.3.3	MME paging and paging retransmission strategy .....	33
4.5.14	Non-IP Data Delivery (NIDD) .....	34
4.5.14.1	General .....	34
4.5.14.2	Enhancements for reliable delivery of NIDD .....	34
4.5.14.3	Reliable Data Service .....	35
4.5.15	Support of PFD management via SCEF .....	35
4.5.16	MSISDN-less MO-SMS via T4 .....	35
4.5.17	Enhanced Coverage Restriction Control via SCEF .....	35
4.5.18	MBMS user service for UEs using power saving functions .....	36
4.5.19	Enhancements to Location Services for CIoT .....	37
4.5.20	MBMS user service for NB or M UE categories .....	37
4.5.21	Network Parameter Configuration via SCEF .....	38
4.6	Identifiers .....	38
4.6.1	General .....	38
4.6.2	External Identifier .....	38
4.6.3	External Group Identifier .....	39
4.7	Addressing .....	39
4.8	Security Aspects .....	39
4.8.1	Security Requirements .....	39
4.8.1.0	General .....	39
4.8.1.1	Void .....	39
4.8.1.2	Void .....	39
4.9	SCEF - SCS/AS API Procedures .....	39
4.9.1	General .....	39
4.9.2	Common Parameters .....	40
4.10	Charging Principles .....	40
5	Functional Description and Information Flow .....	41
5.1	Control and user plane .....	41
5.1.1	Control Plane .....	41
5.1.1.1	HSS – MTC-IWF .....	41
5.2	Device triggering procedures .....	42
5.2.1	Device triggering procedure over Tsp .....	42
5.2.2	Trigger Delivery using T4 .....	43
5.2.3	Device triggering recall/replace procedures .....	44
5.2.3.1	Device trigger recall/replace procedure over Tsp .....	44
5.2.3.2	Replace procedure for trigger delivery using T4 .....	46
5.2.3.3	Recall procedure for trigger delivery using T4 .....	47
5.3	Information Storage .....	48
5.3.0	General .....	48
5.3.1	Trigger Information in SMS-SC (Triggering with T4) .....	48
5.3.2	SCEF .....	48
5.4	Security Procedures .....	49
5.4.0	General .....	49
5.4.1	Void .....	49
5.4.2	Void .....	49
5.5	Group message delivery procedures .....	50
5.5.1	Group message delivery using MBMS .....	50
5.5.2	Modification of previously submitted Group message .....	53
5.5.3	Group Message Delivery via unicast MT NIDD .....	54
5.6	Monitoring Procedures .....	55
5.6.0	Common Parameters .....	55
5.6.1	Monitoring Event configuration and deletion via HSS .....	56

5.6.1.1	Configuration Procedure .....	56
5.6.1.2	Void.....	59
5.6.1.3	Specific Parameters for Monitoring Event: Loss of connectivity .....	59
5.6.1.4	Specific Parameters for Monitoring Event: UE reachability.....	60
5.6.1.5	Specific Parameters for Monitoring Event: Location Reporting.....	61
5.6.1.6	Specific Parameters for Monitoring Event: Change of IMSI-IMEI(SV) Association.....	62
5.6.1.7	Specific Parameters for Monitoring Event: Roaming Status.....	63
5.6.1.8	Specific Parameters for Monitoring Event: Communication failure .....	63
5.6.1.9	Specific Parameters for Monitoring Event: Availability after DDN Failure .....	63
5.6.2	Monitoring Events configuration and deletion directly at the MME/SGSN .....	64
5.6.2.1	Configuration Procedure .....	64
5.6.2.2	Void.....	65
5.6.2.3	Specific Steps for Monitoring Event: Number of UEs present in a geographic area .....	65
5.6.3	Reporting of Monitoring Events from the HSS or the MME/SGSN .....	66
5.6.3.1	Reporting Procedure.....	66
5.6.3.2	Reporting Event: Loss of connectivity.....	68
5.6.3.3	Reporting Event: UE reachability .....	68
5.6.3.4	Reporting Event: Location Reporting .....	68
5.6.3.5	Reporting Event: Change of IMSI-IMEI(SV) association .....	68
5.6.3.6	Reporting Event: Roaming Status .....	69
5.6.3.7	Reporting Event: Communication failure .....	69
5.6.3.8	Reporting Event: Availability after DDN failure .....	69
5.6.4	Monitoring events configuration and reporting via PCRF.....	69
5.6.4.1	Request of monitoring event reporting.....	69
5.6.4.1a	Request of monitoring event reporting for a group of UEs .....	70
5.6.4.2	Common Parameters of the request reporting procedure .....	71
5.6.4.3	Specific Parameters for Monitoring Event: Location Reporting.....	72
5.6.4.4	Specific Parameters for Monitoring Event: Communication Failure .....	72
5.6.5	Reporting of Monitoring Events from the PCRF.....	73
5.6.6	Monitoring Event configuration and deletion via HSS for roaming scenarios using an IWK-SCEF .....	73
5.6.6.1	Configuration Procedure .....	73
5.6.6.2	Void.....	75
5.6.6.3	Specific Parameters for Monitoring Event: Loss of connectivity .....	75
5.6.6.4	Specific Parameters for Monitoring Event: UE reachability.....	75
5.6.6.5	Specific Parameters for Monitoring Event: Location Reporting.....	76
5.6.6.6	Specific Parameters for Monitoring Event: Change of IMSI-IMEI(SV) Association.....	76
5.6.6.7	Specific Parameters for Monitoring Event: Roaming Status.....	76
5.6.6.8	Specific Parameters for Monitoring Event: Communication failure .....	76
5.6.6.9	Specific Parameters for Monitoring Event: Availability after DDN Failure.....	77
5.6.7	Monitoring Events configuration and deletion directly at the MME/SGSN for roaming scenarios .....	77
5.6.8	Reporting of Monitoring Events from the HSS or the MME/SGSN for roaming scenarios .....	77
5.6.8.1	Reporting Procedure.....	77
5.6.8.2	Reporting Event: Loss of connectivity.....	79
5.6.8.3	Reporting Event: UE reachability .....	79
5.6.8.4	Reporting Event: Location Reporting .....	79
5.6.8.5	Reporting Event: Change of IMSI-IMEI(SV) association .....	79
5.6.8.6	Reporting Event: Roaming Status .....	79
5.6.8.7	Reporting Event: Communication failure .....	79
5.6.8.8	Reporting Event: Availability after DDN failure .....	79
5.6.9	Network-initiated Explicit Monitoring Event Deletion Procedure .....	80
5.7	High latency communications procedures.....	80
5.7.1	Availability Notification after DDN Failure .....	80
5.7.1.1	General .....	80
5.7.1.2	Event Configuration .....	81
5.7.1.3	Notification .....	81
5.7.2	Notification using Monitoring Event "UE Reachability" .....	83
5.8	Procedure for Informing about Potential Network Issues .....	83
5.8.1	General.....	83
5.8.2	Request procedure for one-time or continuous reporting of network status .....	84
5.8.3	Report procedure for continuous reporting of network status.....	85
5.8.4	Removal procedure for continuous reporting of network status .....	86
5.9	Procedure for resource management of background data transfer.....	87



5.10	Communication Pattern parameters provisioning procedure.....	88
5.10.1	Communication Pattern parameters .....	88
5.10.2	Communication Pattern parameters provisioning to the MME .....	89
5.11	Setting up an AS session with required QoS procedure .....	91
5.12	Change the chargeable party at session set-up or during the session procedure.....	92
5.12.1	Set the chargeable party at session set-up .....	92
5.12.2	Change the chargeable party during the session .....	93
5.13	Non-IP Data Delivery procedures .....	94
5.13.1	T6a/T6b Connection Establishment.....	94
5.13.1.1	General .....	94
5.13.1.2	T6a/T6b Connection Establishment Procedure .....	94
5.13.2	NIDD Configuration .....	95
5.13.3	Mobile Terminated NIDD procedure.....	97
5.13.4	Mobile Originated NIDD procedure .....	101
5.13.5	T6a/T6b Connection Release.....	101
5.13.5.1	General .....	101
5.13.5.2	MME/SGSN Initiated T6a/T6b Connection Release procedure .....	102
5.13.5.3	SCEF Initiated T6a/T6b Connection Release procedure.....	103
5.13.6	Serving node relocation procedure over T6a/T6b.....	104
5.13.6.1	General .....	104
5.13.6.2	Successful TAU/RAU procedure with T6a/T6b .....	104
5.13.7	Void .....	105
5.13.8	NIDD Authorisation Update .....	105
5.14	PFD management via SCEF.....	105
5.14.1	Procedure for PFD management via SCEF.....	105
5.14.2	PFD definition .....	106
5.15	Procedure for MSISDN-less MO-SMS via T4.....	107
5.16	Procedure for Enhanced Coverage Restriction Control via SCEF .....	108
5.17	Procedures for accessing MTC-IWF Functionality via SCEF.....	109
5.17.1	Device triggering procedure via T8.....	109
5.17.2	Device triggering recall/replace procedures via T8.....	110
5.17.3	Procedure for MSISDN-less MO-SMS via T8.....	111
5.18	Procedure for Network Parameter Configuration via SCEF .....	112
<b>Annex A (Informative):</b>	<b>MTC Deployment Scenarios .....</b>	<b>115</b>
<b>Annex B (Informative):</b>	<b>Void .....</b>	<b>117</b>
<b>Annex C (Informative):</b>	<b>Triggering with OMA Push .....</b>	<b>118</b>
C.1	General .....	118
C.2	Triggering flow using Service Loading.....	118
<b>Annex D (Informative):</b>	<b>Device triggering using direct model over user plane .....</b>	<b>120</b>
<b>Annex E (Informative):</b>	<b>Change history .....</b>	<b>121</b>
History	.....	126

---

# Foreword

This Technical Specification has been produced by the 3rd Generation Partnership Project (3GPP).

The contents of the present document are subject to continuing work within the TSG and may change following formal TSG approval. Should the TSG modify the contents of the present document, it will be re-released by the TSG with an identifying change of release date and an increase in version number as follows:

Version x.y.z

where:

- x the first digit:
  - 1 presented to TSG for information;
  - 2 presented to TSG for approval;
  - 3 or greater indicates TSG approved document under change control.
- y the second digit is incremented for all changes of substance, i.e. technical enhancements, corrections, updates, etc.
- z the third digit is incremented when editorial only changes have been incorporated in the document.

**iTeh STANDARD PREVIEW**  
(standards.iteh.ai)  
Full standard:  
<https://standards.iteh.ai/catalog/standards/sist/727ebb06-bdff-4895-9b32-b87339fafa0f/etsi-ts-123-682-v15.8.0-2019-04>



---

# 1 Scope

The present document specifies architecture enhancements to facilitate communications with packet data networks and applications (e.g. Machine Type Communication (MTC) applications on the (external) network/MTC servers) according to the use cases and service requirements defined in TS 22.368 [2], TS 22.101 [3], and related 3GPP requirements specifications. Both roaming and non-roaming scenarios are covered.

The present document also specifies transmission of non-IP data via SCEF for the CIoT EPS Optimization.

The present document also specifies the interface between the SCEF and the SCS/AS.

---

# 2 References

The following documents contain provisions which, through reference in this text, constitute provisions of the present document.

- References are either specific (identified by date of publication, edition number, version number, etc.) or non-specific.
- For a specific reference, subsequent revisions do not apply.
- For a non-specific reference, the latest version applies. In the case of a reference to a 3GPP document (including a GSM document), a non-specific reference implicitly refers to the latest version of that document *in the same Release as the present document*.

- [1] 3GPP TR 21.905: "Vocabulary for 3GPP Specifications".
- [2] 3GPP TS 22.368: "Service Requirements for Machine-Type Communications (MTC)".
- [3] 3GPP TS 22.101: "Service Aspects; Service Principles".
- [4] 3GPP TS 23.003: "Numbering, addressing and identification".
- [5] 3GPP TS 23.002: "Network architecture".
- [6] 3GPP TS 23.060: "General Packet Radio Service (GPRS); Service description; Stage 2".
- [7] 3GPP TS 23.401: "General Packet Radio Service (GPRS) enhancements for Evolved Universal Terrestrial Radio Access Network (E-UTRAN) access".
- [8] 3GPP TS 29.061: "Interworking between the Public Land Mobile Network (PLMN) supporting Packet Based services and Packet Data Networks (PDN)".
- [9] 3GPP TS 29.303: "Domain Name System Procedures; Stage 3".
- [10] 3GPP TS 23.228: "IP Multimedia Subsystem (IMS); Stage 2".
- [11] 3GPP TS 23.272: "Circuit Switched (CS) fallback in Evolved Packet System (EPS); Stage 2".
- [12] 3GPP TS 23.040: "Technical realization of the Short Message Service (SMS)".
- [13] 3GPP TS 23.204: "Support of Short Message Service (SMS) over generic 3GPP Internet Protocol (IP) access; Stage 2".
- [14] 3GPP TR 23.039: "Interface Protocols for the Connection of Short Message Service Centers (SMSCs) to Short Message Entities (SMEs)".
- [15] IETF RFC 3588: "Diameter Base Protocol".
- [16] IETF RFC 4960: "Stream Control Transmission Protocol".
- [17] [WAP-168-ServiceLoad-20010731-a](#): "Service Loading".
- [18] [OMA-TS-Push\\_MO-V1\\_0-20110809-A](#): "OMA Push Management Object".

- [19] [OMA-TS-Push Message-V2 2-20110809-A](#): "Push Message".
- [20] [OMA-AD-Push-V2 2-20110809-A](#): "Push Architecture".
- [21] 3GPP TS 23.221: "Architectural requirements".
- [22] Void.
- [23] 3GPP TS 23.142: "Value-added Services for SMS (VAS4SMS); Interface and signalling flow".
- [24] 3GPP TS 29.368: "Tsp interface protocol between the MTC Interworking Function (MTC-IWF) and Service Capability Server (SCS)".
- [25] 3GPP TS 33.187: "Security aspects of Machine-Type and other mobile data applications Communications enhancements".
- [26] 3GPP TS 23.402: "Architecture enhancements for non-3GPP accesses".
- [27] 3GPP TS 23.203: "Policy and charging control architecture".
- [28] 3GPP TS 32.240: "Charging architecture and principles".
- [29] 3GPP TS 23.246: "Multimedia Broadcast/Multicast Service (MBMS); Architecture and functional description".
- [30] 3GPP TS 23.468: "Group Communication System Enablers for LTE (GCSE\_LTE); Stage 2".
- [31] 3GPP TS 29.272: "Mobility Management Entity (MME) and Serving GPRS Support Node (SGSN) related interfaces based on Diameter protocol".
- [32] OMA API Inventory: "<http://technical.openmobilealliance.org/API/APIsInventory.aspx>".
- [33] 3GPP TS 23.271: "Functional stage 2 description of Location Services (LCS)".
- [34] 3GPP TS 25.304: "User Equipment (UE) procedures in idle mode and procedures for cell reselection in connected mode".
- [35] 3GPP TS 36.304: "Evolved Universal Terrestrial Radio Access (E-UTRA); User Equipment (UE) procedures in idle mode".
- [36] 3GPP TS 23.012: "Location management procedures".
- [37] 3GPP TS 29.128: "Mobility Management Entity (MME) and Serving GPRS Support Node (SGSN) interfaces for interworking with packet data networks and applications".
- [38] 3GPP TS 26.346: "MBMS: Protocols and Codecs".
- [39] 3GPP TS 32.278: "Monitoring event charging".
- [40] 3GPP TS 32.253: "Control Plane (CP) data transfer domain charging".
- [41] 3GPP TS 36.306: "Evolved Universal Terrestrial Radio Access (E-UTRA); User Equipment (UE) radio access capabilities".
- [42] 3GPP TS 26.347: "Multimedia Broadcast/Multicast Service (MBMS); Application Programming Interface and URL".
- [43] 3GPP TS 23.222: "Functional architecture and information flows to support Common API Framework for 3GPP Northbound APIs".
- [44] 3GPP TS 29.122: "T8 reference point for northbound Application Programming Interfaces (APIs)".
- [45] 3GPP TS 29.336: "Home Subscriber Server (HSS) diameter interfaces for interworking with packet data networks and applications".

## 3 Definitions and abbreviations

### 3.1 Definitions

For the purposes of the present document, the terms and definitions given in TR 21.905 [1] apply.

For the purposes of the present document, the following terms and definitions given in TS 23.401 [7] apply:

#### WB-E-UTRAN

### 3.2 Abbreviations

For the purposes of the present document, the abbreviations given in TR 21.905 [1] and the following apply. An abbreviation defined in the present document takes precedence over the definition of the same abbreviation, if any, in TR 21.905 [1].

AS	Application Server
CDR	Charging Data Record
CDF	Charging Data Function
CGF	Charging Gateway Function
CIoT	Cellular Internet of Things
CP	Communication Pattern
DDN	Downlink Data Notification
IWK-SCEF	Interworking SCEF
MTC	Machine Type Communications
MTC-IWF	Machine Type Communications-InterWorking Function
NIDD	Non-IP Data Delivery
PCRF	Policy and Charging Rules Function
P-GW	PDN Gateway
PFDF	Packet Flow Description Function
PSM	Power Saving Mode
SCEF	Service Capability Exposure Function
SCS	Services Capability Server
SLF	Subscriber Location Function
SME	Short Message Entities
SMS-SC	Short Message Service-Service Centre
SRI	Send Routing Information
WB-E-UTRAN	Wide Band E-UTRAN

## 4 Architecture Model and Concepts

### 4.1 General Concept

The end-to-end communications, between the MTC Application in the UE and the MTC Application in the external network, uses services provided by the 3GPP system, and optionally services provided by a Services Capability Server (SCS).

The MTC Application in the external network is typically hosted by an Application Server (AS) and may make use of an SCS for additional value added services. The 3GPP system provides transport, subscriber management and other communication services including various architectural enhancements motivated by, but not restricted to, MTC (e.g. control plane device triggering).

Different models are foreseen for machine type of traffic in what relates to the communication between the AS and the 3GPP system (refer to Annex A) and based on the provider of the SCS. The different architectural models that are supported by the Architectural Reference Model in clause 4.2 include the following:

- Direct Model - The AS connects directly to the operator network in order to perform direct user plane communications with the UE without the use of any external SCS. The Application in the external network may make use of services offered by the 3GPP system;
- Indirect Model - The AS connects indirectly to the operator network through the services of a SCS in order to utilize additional value added services for MTC (e.g. control plane device triggering). The SCS is either:
  - MTC Service Provider controlled: The SCS is an entity that may include value added services for MTC, performing user plane and/or control plane communication with the UE. Tsp is regarded as an inter-domain interface for control plane communication; or
  - 3GPP network operator controlled: The SCS is a mobile operator entity that may include value added services for MTC and performs user plane and/or control plane communication with the UE, making Tsp a control plane interface internal to the PLMN;
- Hybrid Model: The AS uses the direct model and indirect models simultaneously in order to connect directly to the operator's network to perform direct user plane communications with the UE while also using a SCS. From the 3GPP network perspective, the direct user plane communication from the AS and any value added control plane related communications from the SCS are independent and have no correlation to each other even though they may be servicing the same MTC Application hosted by the AS.

When using the hybrid model, the MTC Service provider controlled SCS, and the 3GPP operator controlled SCS may offer different capabilities to the MTC Applications.

Since the different models are not mutually exclusive, but just complementary, it is possible for a 3GPP operator to combine them for different applications. This may include a combination of both MTC Service Provider and 3GPP network operator controlled SCSs communicating with the same PLMN.

## 4.2 Architectural Reference Model

Figures 4.2-1a and 4.2-1b show the architecture for a UE used for MTC connecting to the 3GPP network (UTRAN, E-UTRAN, GERAN, etc.) via the Um/Uu/LTE-Uu interfaces. They also show the 3GPP network service capability exposure to SCS and AS. The architecture covers the various architectural models described in clause 4.1.

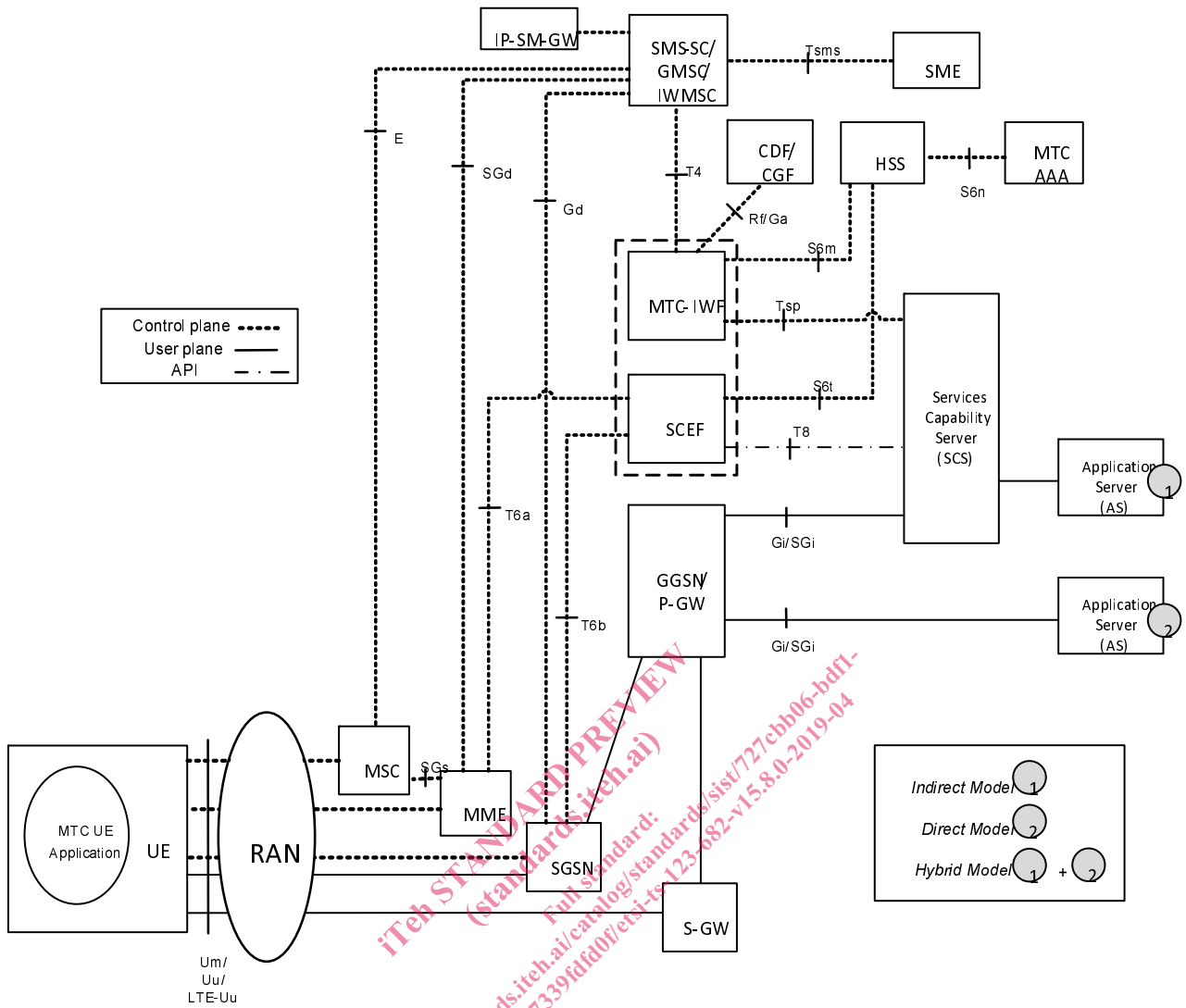

Figure 4.2-1a: 3GPP Architecture for Machine-Type Communication (non-roaming)