

# DRAFT INTERNATIONAL STANDARD

## ISO/DIS 3917

ISO/TC 22/SC 11

Secretariat: ANSI

Voting begins on:  
2014-03-24

Voting terminates on:  
2014-06-24

---

---

## Road vehicles — Safety glazing materials — Test methods for resistance to radiation, high temperature, humidity, fire and simulated weathering

*Véhicules routiers — Vitrages de sécurité — Méthodes d'essai de résistance au rayonnement, aux températures élevées, à l'humidité, au feu et aux conditions climatiques simulées*

[Revision of third edition (ISO 3917:1999)]

ICS: 43.040.65;81.040.30

**iTeh STANDARD PREVIEW**  
(standards.iteh.ai)

Full standard:  
<https://standards.iteh.ai/catalog/standards/sist/60b22-4a6-8df2-4931-921f-012ada0d2f7e/iso-3917-2016>

THIS DOCUMENT IS A DRAFT CIRCULATED FOR COMMENT AND APPROVAL. IT IS THEREFORE SUBJECT TO CHANGE AND MAY NOT BE REFERRED TO AS AN INTERNATIONAL STANDARD UNTIL PUBLISHED AS SUCH.

IN ADDITION TO THEIR EVALUATION AS BEING ACCEPTABLE FOR INDUSTRIAL, TECHNOLOGICAL, COMMERCIAL AND USER PURPOSES, DRAFT INTERNATIONAL STANDARDS MAY ON OCCASION HAVE TO BE CONSIDERED IN THE LIGHT OF THEIR POTENTIAL TO BECOME STANDARDS TO WHICH REFERENCE MAY BE MADE IN NATIONAL REGULATIONS.

RECIPIENTS OF THIS DRAFT ARE INVITED TO SUBMIT, WITH THEIR COMMENTS, NOTIFICATION OF ANY RELEVANT PATENT RIGHTS OF WHICH THEY ARE AWARE AND TO PROVIDE SUPPORTING DOCUMENTATION.



Reference number  
ISO/DIS 3917:2014(E)

© ISO 2014

**iTeh STANDARD PREVIEW**  
(standards.iteh.ai)

Full standard:  
<https://standards.iteh.ai/catalog/standards/sist/60b22-4a6-8df2-4931-921f-012ada0d2f7e/iso-3917-2016>

### Copyright notice

This ISO document is a Draft International Standard and is copyright-protected by ISO. Except as permitted under the applicable laws of the user's country, neither this ISO draft nor any extract from it may be reproduced, stored in a retrieval system or transmitted in any form or by any means, electronic, photocopying, recording or otherwise, without prior written permission being secured.

Requests for permission to reproduce should be addressed to either ISO at the address below or ISO's member body in the country of the requester.

ISO copyright office  
Case postale 56 • CH-1211 Geneva 20  
Tel. + 41 22 749 01 11  
Fax + 41 22 749 09 47  
E-mail [copyright@iso.org](mailto:copyright@iso.org)  
Web [www.iso.org](http://www.iso.org)

Reproduction may be subject to royalty payments or a licensing agreement.

Violators may be prosecuted.

## Contents

Page

Foreword .....	iv
1 Scope .....	1
2 Normative references .....	1
3 Terms and definitions .....	1
4 Test conditions .....	1
5 Application of test .....	1
6 Radiation test .....	2
6.1 Principle .....	2
6.2 Apparatus .....	2
6.2.1 Radiation source .....	2
6.2.2 Power supply .....	2
6.2.3 Device for mounting and rotating the test specimens .....	2
6.3 Test specimen .....	2
6.4 Expression of results .....	2
7 High temperature test .....	3
7.1 Principle .....	3
7.2 Procedure .....	3
7.3 Expression of results .....	3
8 Humidity test .....	3
8.1 Principle .....	3
8.2 Procedure .....	3
8.3 Expression of results .....	4
9 Fire Resistance Test .....	4
9.1 Principle .....	4
9.2 Apparatus .....	4
9.3 Test specimens .....	4
9.4 Test Procedure .....	4
10 Resistance to simulated weathering .....	6
10.1 Principle .....	6
10.2 Exposure apparatus .....	6
10.2.1 Light sources .....	6
10.3 Test specimens .....	6
10.4 Procedure .....	7
10.5 Evaluation .....	8
10.6 Expression of results .....	8
10.7 Report of test parameters .....	8

## Foreword

ISO (the International Organization for Standardization) is a worldwide federation of national standards bodies (ISO member bodies). The work of preparing International Standards is normally carried out through ISO technical committees. Each member body interested in a subject for which a technical committee has been established has the right to be represented on that committee. International organizations, governmental and non-governmental, in liaison with ISO, also take part in the work. ISO collaborates closely with the International Electrotechnical Commission (IEC) on all matters of electrotechnical standardization.

International Standards are drafted in accordance with the rules given in the ISO/IEC Directives, Part 2.

The main task of technical committees is to prepare International Standards. Draft International Standards adopted by the technical committees are circulated to the member bodies for voting. Publication as an International Standard requires approval by at least 75 % of the member bodies casting a vote.

Attention is drawn to the possibility that some of the elements of this document may be the subject of patent rights. ISO shall not be held responsible for identifying any or all such patent rights.

ISO 3917 was prepared by Technical Committee ISO/TC 22, *Road Vehicles*, Subcommittee SC 11, *Safety glazing materials*.

This fourth edition cancels and replaces the fthird edition (ISO 3917:1999), which has been technically revised.

**ITeH STANDARD PREVIEW**  
(standards.iteh.ai)  
Full standard:  
<https://standards.iteh.ai/catalog/standards/sist/60b224a6-8df2-4931-921f-012ada0d2f7e/iso-3917-2016>

# Road vehicles — Safety glazing materials — Test methods for resistance to radiation, high temperature, humidity, fire and simulated weathering

## 1 Scope

This International Standard specifies test methods for resistance to radiation, high temperature, humidity, fire and simulated weathering, relating to the safety requirements for all safety glazing materials in a road vehicle, whatever the type of glass or the material of which they are composed.

## 2 Normative references

The following normative documents contain provisions which, through reference in this text, constitute provisions of this International Standard. For dated references, subsequent amendments to, or revisions of, any of these publications do not apply. However, parties to agreements based on this International Standard are encouraged to investigate the possibility of applying the most recent editions of the normative documents indicated below. For undated references, the latest edition of the normative document referred to applies. Members of ISO and IEC maintain registers of currently valid International Standards.

ISO 3536, *Road vehicles — Safety glazing materials — Vocabulary*

ISO 3537, *Road vehicles — Safety glazing materials — Mechanical tests*

ISO 3538, *Road vehicles — Safety glazing materials — Test methods for optical properties*

ISO 3795, *Road vehicles, and tractors and machinery for agriculture and forestry — Determination of burning behaviour of interior materials*

ISO 4892-1, *Plastics — Methods of exposure to laboratory light sources — Part 1: General guidance*

ISO 4892-2, *Plastics — Methods of exposure to laboratory light sources — Part 2: Xenon-arc sources*

## 3 Terms and definitions

For the purposes of this International Standard, the terms and definitions given in ISO 3536 apply.

## 4 Test conditions

Unless otherwise specified, the test shall be carried out under the following conditions:

- ambient temperature:  $20\text{ °C} \pm 5\text{ °C}$ ;
- atmospheric pressure: 86 kPa to 106 kPa (860 mbar to 1 060 mbar);
- relative humidity:  $(60 \pm 20)\%$ .

## 5 Application of test

For certain types of safety glazing material, it is not necessary to carry out all the tests specified in this International Standard.

## 6 Radiation test

### 6.1 Principle

Determination of whether exposure to radiation over an extended period of time produces any appreciable decrease in regular luminous transmittance or any pronounced discoloration of the safety glazing material.

### 6.2 Apparatus

#### 6.2.1 Radiation source

Radiation source, consisting of a medium pressure mercury arc lamp with a tubular quartz bulb of ozone-free type. The bulb axis shall be vertical and equipped with a suitable filter tube removing radiation below 300nm. The lamp operation parameters must be lamp power of  $750 \text{ W} \pm 50 \text{ W}$ .<sup>1)</sup>

Any other source of radiation which produces the same effect as the lamp specified above may be used. To check that the effects of another source are the same, a comparison shall be made by measuring the amount of energy emitted within a wavelength range of 300 nm to 450 nm, all other wavelengths being removed by the use of suitable filters. The alternative source shall then be used with these filters.

In the case of safety glazing material for which there is no satisfactory correlation between this test and the conditions of use, it will be necessary to review the test conditions.

#### 6.2.2 Power supply

The power supply shall be capable of supplying adequate power to the lamp.

#### 6.2.3 Device for mounting and rotating the test specimens

The device shall be capable of mounting and rotating the test specimens at 1 r/min to 5 r/min about the centrally located radiation source in order to ensure even exposure.

### 6.3 Test specimen

The size of the test specimens shall be 76 mm × 300 mm.

#### 6.3.1 Procedure

Measure the regular luminous transmittance, determined according to ISO 3538, of three test specimens before exposure. Protect a portion of each test specimen from the radiation, and then position the test specimen in the test apparatus 230 mm from, and with its 300 mm dimension parallel to, the lamp axis. Maintain the temperature of the test specimens at  $45 \text{ °C} \pm 5 \text{ °C}$  throughout the test.

The surface of each test specimen which would represent the outside face of the safety glazing material when mounted on the vehicle shall face the lamp. For the type of lamp specified in 6.2.1, the exposure time shall be 100 h.

After exposure, measure the luminous transmittance again on each test specimen in the exposed area.

### 6.4 Expression of results

The results of the luminous transmission measurement of the exposed test specimen shall be compared with the values obtained for unexposed test specimens of the same material.

Changes in colour shall be evaluated:

---

1) A medium pressure mercury arc lamp which yields radiation spectra in the appropriate range at the specified operating parameters is available under the trade name Heraeus Noblelight Q 701, modified by means of a UV-C filter tube.

- either by examining the test specimens placed upon a white background and comparing the exposed area with the area which was protected from the radiation;
- or by measuring the trichromatic coordinates of the test specimen before and after ageing and by calculating the difference between two colours according to the CIE <sup>2)</sup> prescriptions.

## 7 High temperature test

### 7.1 Principle

Determination of whether the safety glazing material will withstand exposure to high temperatures over an extended period of time without its appearance becoming substantially altered.

### 7.2 Procedure

Heat one or more test specimens of at least 300 mm × 300 mm to 100 °C  $\pm$  2 °C. Maintain this temperature for a period of 2 h, then allow the test specimen(s) to cool to room temperature.

If the safety glazing material has both external surfaces of inorganic material, the test may be carried out by immersing the test specimen vertically in water boiling at 100 °C  $\pm$  2 °C for the specified period of time, care being taken to avoid undue thermal shock.

If specimens are cut from windscreens, one edge of the test specimen shall be part of an edge of the windscreen.

### 7.3 Expression of results

The resistance of the safety glazing material to high temperatures shall be evaluated with reference to bubbles or other defects produced in the test specimen by the test described in 7.2.

Any defects within 15 mm of an uncut edge, 25 mm from a cut edge or within 10 mm of any cracks which may develop shall be disregarded.

Any test specimen in which cracks develop to an extent which might confuse the results shall be discarded and another test specimen shall be tested in its place.

## 8 Humidity test

### 8.1 Principle

Determination of whether the safety glazing material will successfully withstand the effects of humidity in the atmosphere over an extended period of time.

### 8.2 Procedure

Keep one or more test specimens of at least 300 mm × 300 mm vertically for two weeks in a closed container in which the temperature is maintained at 50 °C  $\pm$  2 °C and the relative humidity at (95  $\pm$  4) %.

These test conditions should exclude any condensation on test specimens.

In the event that several test specimens are tested at the same time, adequate spacing shall be provided between the test specimens.

Precautions shall be taken to prevent condensate from the walls and ceiling of the test chamber from falling on the test specimens.

2) International Commission on Illumination

If the test specimens are cut from windscreens, one edge of the test specimen shall be part of an edge of the windscreen.

### 8.3 Expression of results

The resistance to humidity shall be evaluated visually by reference to change in the appearance of the safety glazing material after testing, i.e.:

- separation of materials;
- loss of transparency according to ISO 3538.

A waiting period of 48 h after exposure prior to evaluation is permitted, if necessary.

The changes shall be assessed over the whole test specimen and any changes which extend more than 6.0 mm from an uncut edge or 10 mm from a cut edge shall be reported-

## 9 Fire Resistance Test

Alternatively, the apparatus and method described in ISO 3795 may be used.

### 9.1 Principle

The purpose of this test is to determine the horizontal burning rate of safety glazing materials, of which at least one surface is plastic, after exposure to a small flame.

### 9.2 Apparatus

- a) The test shall be conducted in a laboratory hood or draft-free enclosure greater than 0.5 m<sup>3</sup> in size and provided with a means for venting the fumes from burning test specimens samples. If a hood is used, its exhaust fan will be turned off during the test but allowed to run periodically to clear out the fumes between tests.
- b) The test specimen shall be clamped in a suitable holder, at the end farthest from the 25 mm mark, with its longitudinal axis horizontal and its transverse axis inclined at 45 degrees to the horizontal. The specimen is held with the plastic surface downward, facing the flame.
- c) Under the test specimen there shall be clamped a 20 mesh per 25.4 mm Bunsen burner gauze, about 125 mm square, in a horizontal position 6 mm below the edge of the test specimen and with about 13 mm of the test specimen extending beyond the edge of the gauze as illustrated in Figure 1.
- d) The flame is provided by a Bunsen burner. The gas supplied to the burner shall have a caloric value of about 38 MJ/m<sup>3</sup> (for example, natural gas).

### 9.3 Test specimens

- a) At least three 150 mm x 13 mm flat test samples specimens shall be tested. The test specimens shall be marked by inscribing two lines, 25 mm and 100 mm from one end of each specimen.
- b) The specimens shall be conditioned for at least 48 hours, at a temperature of 23 °C ± 2 °C and a relative humidity of 50 ± 5 per cent, and shall be maintained under these conditions until immediately prior to the test.

### 9.4 Test Procedure

- a) A Bunsen burner with a stable, blue, gas flame 12 mm to 20 mm in height shall be placed under the free end of the test specimen and adjusted so that the flame tip is just in contact with the test specimen.



- b) At the end of 30 s, the flame shall be removed and the test specimen allowed to burn.
- c) A stop watch shall be started when the flame reaches the first mark, 25 mm from the free end, and the time recorded when the flame reaches the 100 mm mark.
- d) In case the test specimen does not continue to burn after the first ignition, the burner shall be placed under the free end for a second period of 30 s immediately following extinction of the flame burning.

## 9.2 Expression of results

The horizontal burning rate of each test specimen, as well as the average of all specimens tested, shall be recorded in millimetres per minute according to the formula:

$$B = s/t \times 60$$

where;

s is the burnt distance in millimetres

t is the time in seconds, taken to burn the distance s

If the specimen does not ignite or does not continue to burn, reaching the first mark, after the gas flame has been removed, a burning rate of 0 mm/min. shall be reported.

If a test specimen does not continue burning to the 100 mm mark after a second ignition with the gas flame, it shall be reported as non-sustaining.

Dimensions in millimetres

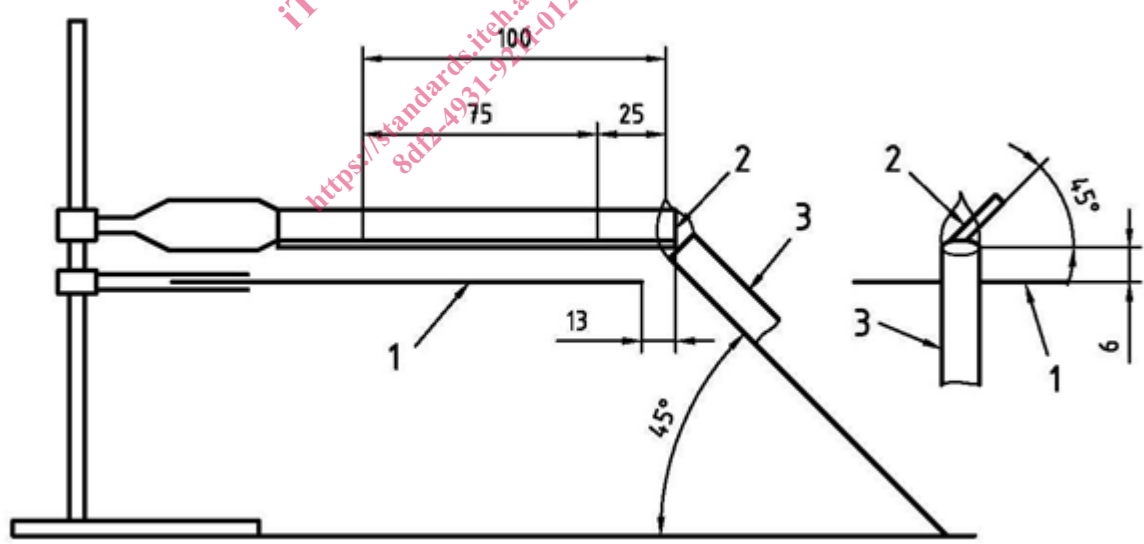

Key

- 1 Wire gauze  
2 Test specimen  
3 Burner

Figure 1 — Horizontal burning test