



SLOVENSKI STANDARD  
SIST ISO 1180:2002  
01-december-2002

GHVUdbYj a Uhg\_l `cfcX]^b'df]\_`1 bYa YfY'di y'j dYb'Ub] \ [ `Uj

Shanks for pneumatic tools and fitting dimensions of chuck bushings

Queues d'outils pneumatiques et dimensions d'interchangeabilité des douilles porte-outil

ITEH STANDARD PREVIEW  
(standards.iteh.ai)

Ta slovenski standard je istoveten z: ISO 1180:1983

SIST ISO 1180:2002

<https://standards.iteh.ai/catalog/standards/sist/82d03d90-d3a3-4e3a-8db5-0b5c459830c1/sist-iso-1180-2002>

**ICS:**

25.140.10 Ú} ^ç{ æã } æñ | [ åæ Pneumatic tools

**SIST ISO 1180:2002 en**

**iTeh STANDARD PREVIEW**  
**(standards.iteh.ai)**

SIST ISO 1180:2002

<https://standards.iteh.ai/catalog/standards/sist/82d03d90-d3a3-4e3a-8db5-0b5c459830c1/sist-iso-1180-2002>

---

International Standard



1180

---

INTERNATIONAL ORGANIZATION FOR STANDARDIZATION • МЕЖДУНАРОДНАЯ ОРГАНИЗАЦИЯ ПО СТАНДАРТИЗАЦИИ • ORGANISATION INTERNATIONALE DE NORMALISATION

---

## Shanks for pneumatic tools and fitting dimensions of chuck bushings

*Queues d'outils pneumatiques et dimensions d'interchangeabilité des douilles porte-outil*

First edition — 1983-12-15

ITeH STANDARD PREVIEW  
(standards.iteh.ai)

[SIST ISO 1180:2002](https://standards.iteh.ai/catalog/standards/sist/82d03d90-d3a3-4e3a-8db5-0b5c459830c1/sist-iso-1180-2002)

<https://standards.iteh.ai/catalog/standards/sist/82d03d90-d3a3-4e3a-8db5-0b5c459830c1/sist-iso-1180-2002>

---

UDC 621.9.02 : 621.542

Ref. No. 1180-1983 (E)

Descriptors : tools, shanks, interchangeability, dimensional tolerances, tolerance of position.

## Foreword

ISO (the International Organization for Standardization) is a worldwide federation of national standards bodies (ISO member bodies). The work of developing International Standards is carried out through ISO technical committees. Every member body interested in a subject for which a technical committee has been authorized has the right to be represented on that committee. International organizations, governmental and non-governmental, in liaison with ISO, also take part in the work.

Draft International Standards adopted by the technical committees are circulated to the member bodies for approval before their acceptance as International Standards by the ISO Council.

International Standard ISO 1180 was developed by Technical Committee ISO/TC 29, *Small tools*, and was circulated to the member bodies in November 1981.

It has been approved by the member bodies of the following countries :

Austria	India	South Africa, Rep. of
Belgium	Israel	Spain
China	Italy	Sweden
Czechoslovakia	Korea, Dem. P. Rep. of	Switzerland
Egypt, Arab Rep. of	Korea, Rep. of	United Kingdom
France	Mexico	USSR
Hungary	Romania	Yugoslavia

The member body of the following country expressed disapproval of the document on technical grounds :

Germany, F.R.

This International Standard cancels and replaces ISO Recommendation R 1180-1970 and ISO Recommendation R 1571-1970, of which it constitutes a technical revision.

# Shanks for pneumatic tools and fitting dimensions of chuck bushings

## iTeh STANDARD PREVIEW (standards.iteh.ai)

### 1 Scope and field of application

This International Standard relates to shanks for pneumatic tools and corresponding chuck bushings and deals with the following types :

- coal pick shanks;
- chisel shanks;
- rivet snap shanks, parallel;
- rivet snap shanks, tapered;
- breaker and spade shanks;
- concrete breaker shanks;
- rock drill shanks.

The types relate to the machine for which they are mainly designed, but this does not prevent the use of the shanks for other applications.

Other types of tools will be dealt with in further International Standards when the corresponding studies are completed.

Pneumatic hammers and their chuck bushings are not covered by this International Standard but those features of chuck bushings (dimensions and tolerances) which ensure interchangeability are specified.

For each tool mentioned above, this International Standard provides tables giving dimensions in millimetres.

Dimensions in inches are given in the annex which be valid for five years from the date when this International Standard is approved.

### 2 Reference

ISO 723, *Rock-drilling — Forged collared shanks and chuck bushings for hollow hexagonal drill steels.*

### 3 Interchangeability

The numerical values specified in this International Standard ensure interchangeability even if the shank and the corresponding chuck bushing are not manufactured in the same system of units.

### 4 Designation of shanks

The designation of shanks should be composed of

- the name of the type of shank;
- the shank size (first column in the tables);
- the length of the shank.

*Example :*

**Breaker shank 25 × 108**

## 5 Coal pick shanks and corresponding chuck bushings

Dimension and tolerances in millimetres

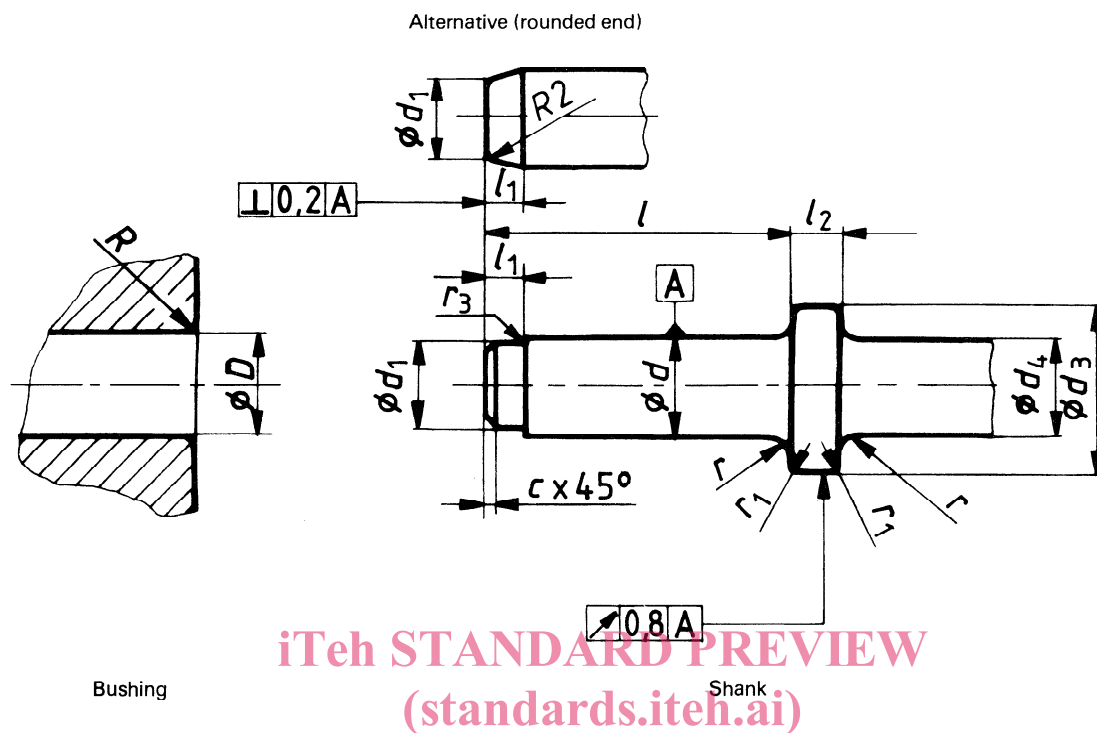

Figure 1 — Coal pick shanks and corresponding chuck bushings

<https://standards.iteh.ai/catalog/standards/sist/82d03d90-d3a3-4e3a-8db5-0b5c459830c1/sist-iso-1180-2002>

Table 1

Dimensions and tolerances in millimetres

Nominal size	Shank											Bushing			
	$d$	$l$	$l_1$	$l_2$		$d_1$	$d_3$	$d_4$		$r$	$r_1$	$r_3$	$c$	$D$	$R$
	f8	h14	$\pm 0,5$	min.	max.	$j_{s14}$	$+ 0,3$ $- 0,5$	min.	max.	$0$ $- 0,5$	$0$ $- 1$	$\pm 0,5$		H8	$+ 0,5$ $0$
25	25	75	10	9,5	13	22	41,5	25	27	5,25	2	3	1,6	25	5,25

Example of designation

Coal pick shank 25 × 75

6 Chisel shanks and corresponding chuck bushings

6.1 Tool with hexagonal shank

Tolerances in millimetres

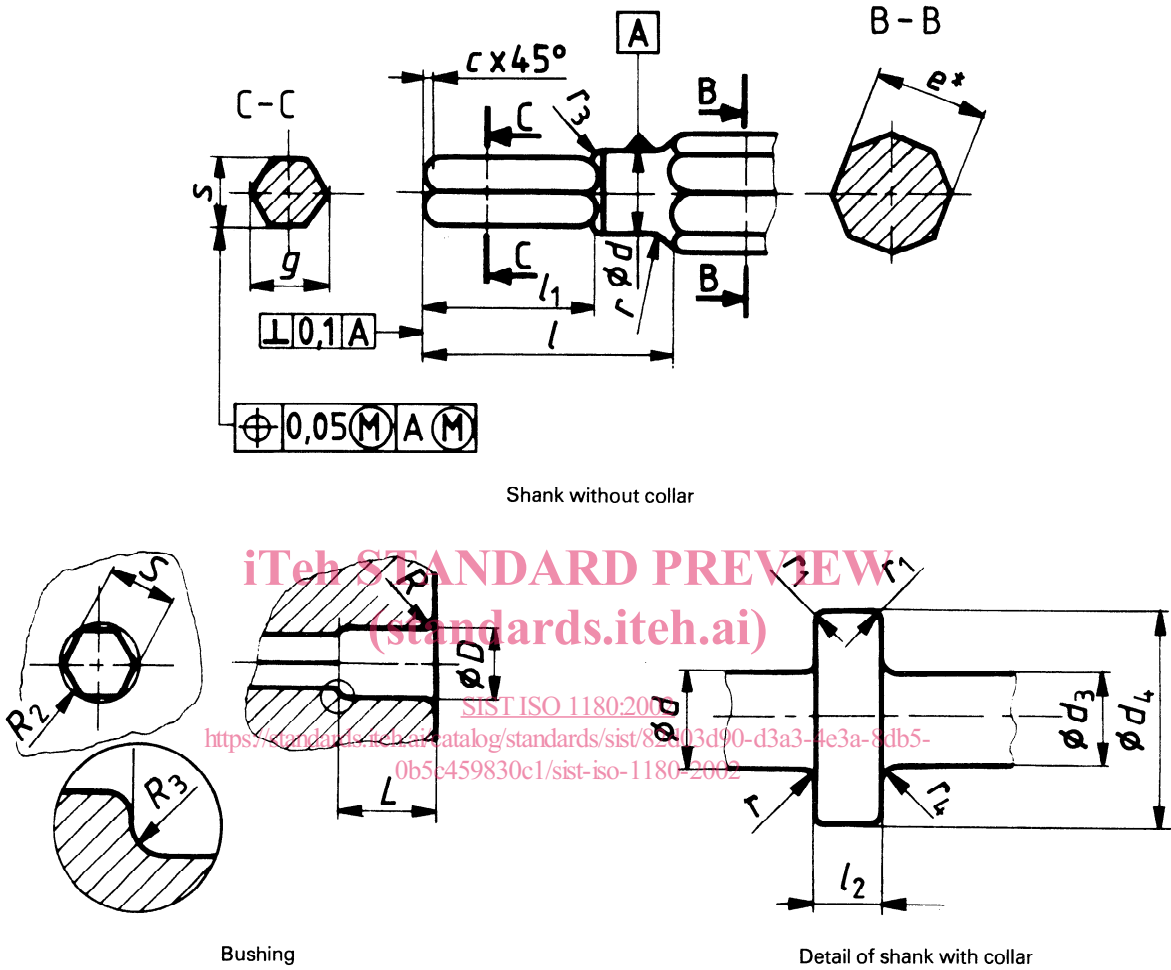

Figure 2 – Tool with hexagonal shank

Table 2

Dimensions and tolerances in millimetres

Nominal size	Shank														Bushing					
	<i>d</i>	<i>l</i>	<i>l</i> <sub>1</sub>	<i>l</i> <sub>2</sub>	<i>d</i> <sub>3</sub>	<i>d</i> <sub>4</sub>	<i>e</i> *	<i>s</i>	<i>g</i>	<i>r</i>	<i>r</i> <sub>1</sub>	<i>r</i> <sub>3</sub>	<i>r</i> <sub>4</sub>	<i>c</i>	<i>D</i>	<i>L</i>	<i>S</i>	<i>R</i>	<i>R</i> <sub>2</sub>	<i>R</i> <sub>3</sub>
	d8	± 0,5	± 0,5	± 1	max.	± 1		d11	<sup>0</sup> <sub>-0,3</sub>	max.		max.	max.		H8	± 1	H11	<sup>+0,5</sup> <sub>0</sub>	± 0,5	± 0,5
12	12,7	45	31	6	13	21	16	11,0	12,1	4	0,8	6	3	0,8	12,7	17	11,0	4	1	1
17	17,3	60	41	9	20	30	22	14,8	16,6	4	0,8	10	3,2	1,6	17,3	22	14,8	4	1	1
20	(20,0)	60	36	9	24	34	25	17,0	19,0	6	0,8	10	3,2	1,6	(20,0)	27	17,0	6	1	1

\* The octagonal shape on the tool side and dimension *e* are given for information only.

## ISO 1180-1983 (E)

## NOTES

- 1 When a smaller shank size is needed, use dimensions presented for rivet snap shanks (size 10, see clause 7).
- 2 The permitted errors of concentricity between the cylindrical portion  $d$  and the hexagonal portion  $s$  are included in the tolerance given in table 2; the "Go" gauge for dimensions  $d$  and  $s$  should therefore be a composite gauge. This remark also refers to the measurements of the corresponding chuck bushings.
- 3 As an alternative to tool with hexagon shank (see figure 2) the hexagon portion may be replaced by a cylindrical portion with the same length  $l_1$  and a diameter  $s$  equal to the width across flats of the hexagon (see figure 3).

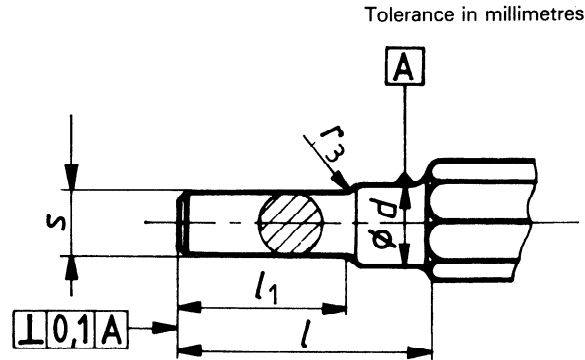

Figure 3 — Alternative shank

- 4 On shanks with a hexagon portion, the cutting edge of the chisel should be parallel to one of the sides of the hexagon.

*Example of designation*

**Chisel shank, hexagonal 12 × 45**

SIST ISO 1180:2002

<https://standards.iteh.ai/catalog/standards/sist/82d03d90-d3a3-4e3a-8db5-0b5c459830c1/sist-iso-1180-2002>



## 6.2 Tool with parallel shank

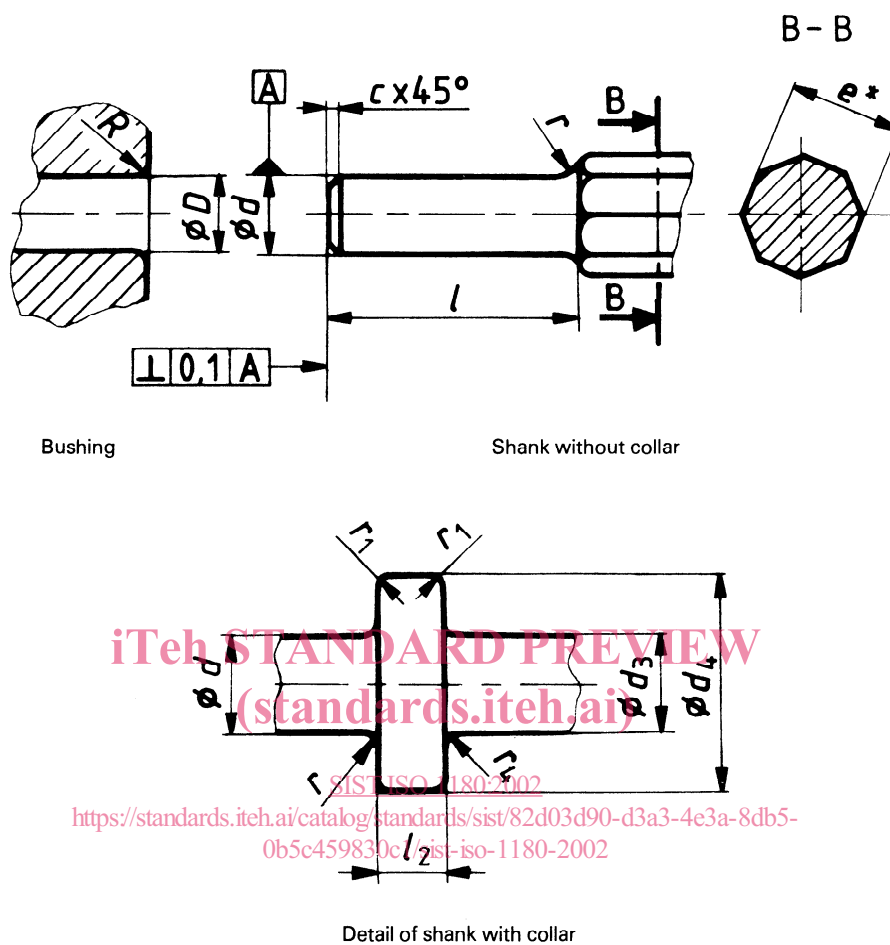

Figure 4 — Tool with parallel shank

Table 3

Dimensions and tolerances in millimetres

Nominal size	Shank										Bushing	
	$d$	$l$	$l_2$	$e^*$	$d_3$	$d_4$	$r$	$r_1$	$r_4$	$c$	$D$	$R$
	d8	$\pm 0,5$	$\pm 1$		max.	$\pm 1$	max.		max.		H8	$+0,5$ 0
12	12,7	45	6	16	13	21	4	0,8	3	0,8	12,7	4
17	17,3	60	9	22	20	30	4	0,8	3,2	1,6	17,3	4
20	(20,0)	60	9	25	24	34	6	0,8	3,2	1,6	(20,0)	6

\* The octogonal shape on the tool side and dimension  $e$  are given for information only.

NOTE — When a smaller shank size is needed, use dimensions presented for rivet snap shanks (size 10, see clause 7).

Example of designation

Chisel shank, parallel 12 × 45