**Rubber, vulcanized or thermoplastic —
Determination of tear strength —**

**Part 2:
Small (Delft) test pieces**

*Caoutchouc vulcanisé ou thermoplastique — Détermination de la
résistance au déchirement — Partie 2: Petites éprouvettes (éprouvettes
de Delft)*

iTeh STANDARD PREVIEW
(standards.iteh.ai)

[ISO 34-2:2011](https://standards.iteh.ai/catalog/standards/sist/a90e27b0-3a32-40f7-b05d-4b15c7d3759c/iso-34-2-2011)

<https://standards.iteh.ai/catalog/standards/sist/a90e27b0-3a32-40f7-b05d-4b15c7d3759c/iso-34-2-2011>



iTeh STANDARD PREVIEW (standards.iteh.ai)

ISO 34-2:2011

<https://standards.iteh.ai/catalog/standards/sist/a90e27b0-3a32-40f7-b05d-4b15c7d3759c/iso-34-2-2011>



COPYRIGHT PROTECTED DOCUMENT

© ISO 2011

All rights reserved. Unless otherwise specified, no part of this publication may be reproduced or utilized in any form or by any means, electronic or mechanical, including photocopying and microfilm, without permission in writing from either ISO at the address below or ISO's member body in the country of the requester.

ISO copyright office
Case postale 56 • CH-1211 Geneva 20
Tel. + 41 22 749 01 11
Fax + 41 22 749 09 47
E-mail copyright@iso.org
Web www.iso.org

Published in Switzerland

Contents

Page

Foreword	iv
1 Scope	1
2 Normative references	1
3 Principle	1
4 Apparatus	1
5 Calibration	2
6 Test pieces	2
6.1 Shape and dimensions	2
6.2 Measurement of dimensions	2
6.3 Time interval between vulcanization and testing	6
6.4 Number	6
7 Temperature of test	6
8 Procedure	6
9 Expression of results	6
10 Precision	7
11 Test report	7
Annex A (informative) Precision	8
Annex B (normative) Calibration schedule	12
Bibliography	13

<https://standards.iteh.ai/catalog/standards/sist/a90e27b0-3a32-40f7-b05d-4b15c7d3759c/iso-34-2-2011>

Foreword

ISO (the International Organization for Standardization) is a worldwide federation of national standards bodies (ISO member bodies). The work of preparing International Standards is normally carried out through ISO technical committees. Each member body interested in a subject for which a technical committee has been established has the right to be represented on that committee. International organizations, governmental and non-governmental, in liaison with ISO, also take part in the work. ISO collaborates closely with the International Electrotechnical Commission (IEC) on all matters of electrotechnical standardization.

International Standards are drafted in accordance with the rules given in the ISO/IEC Directives, Part 2.

The main task of technical committees is to prepare International Standards. Draft International Standards adopted by the technical committees are circulated to the member bodies for voting. Publication as an International Standard requires approval by at least 75 % of the member bodies casting a vote.

Attention is drawn to the possibility that some of the elements of this document may be the subject of patent rights. ISO shall not be held responsible for identifying any or all such patent rights.

ISO 34-2 was prepared by Technical Committee ISO/TC 45, *Rubber and rubber products*, Subcommittee SC 2, *Testing and analysis*.

This third edition cancels and replaces the second edition (ISO 34-2:2007), of which it constitutes a minor revision. The force-measuring accuracy of the tensile-testing machine has been modified to class 1 in Clause 4, the layout of Clause 11 has been updated and a calibration schedule has been added as Annex B.

ISO 34 consists of the following parts, under the general title *Rubber, vulcanized or thermoplastic — Determination of tear strength*:

— Part 1: *Trouser, angle and crescent test pieces*

— Part 2: *Small (Delft) test pieces*

ITeH STANDARD PREVIEW
(standards.iteh.ai)
<https://standards.iteh.ai/catalog/standards/sist/a90e27b0-3a32-40f7-b05d-4b15c7d3759c/iso-34-2-2011>
ISO 34-2:2011

Rubber, vulcanized or thermoplastic — Determination of tear strength —

Part 2: Small (Delft) test pieces

WARNING — Persons using this part of ISO 34 should be familiar with normal laboratory practice. This part of ISO 34 does not purport to address all of the safety problems, if any, associated with its use. It is the responsibility of the user to establish appropriate safety and health practices and to ensure compliance with any national regulatory conditions.

IMPORTANT — Certain procedures specified in this part of ISO 34 might involve the use or generation of substances, or the generation of waste, that could constitute a local environmental hazard. Reference should be made to appropriate documentation on safe handling and disposal after use.

1 Scope

This part of ISO 34 specifies a method for the determination of the tear strength of small test pieces (Delft test pieces) of vulcanized or thermoplastic rubber.

NOTE The method does not necessarily give results agreeing with those given by the method described in ISO 34-1, which uses trouser, angle and crescent test pieces. It is used in preference to ISO 34-1 when the amount of material available is limited, and might be particularly suitable for testing small finished products.

2 Normative references

The following referenced documents are indispensable for the application of this document. For dated references, only the edition cited applies. For undated references, the latest edition of the referenced document (including any amendments) applies.

ISO 5893, *Rubber and plastics test equipment — Tensile, flexural and compression types (constant rate of traverse) — Specification*

ISO 18899:2004, *Rubber — Guide to the calibration of test equipment*

ISO 23529:2010, *Rubber — General procedures for preparing and conditioning test pieces for physical test methods*

3 Principle

The force required to tear across the width of a small test piece containing a slit in the centre is measured.

4 Apparatus

4.1 Tensile-testing machine, complying with the requirements of ISO 5893, capable of measuring force with an accuracy corresponding to class 1 as defined in ISO 5893, and with a rate of traverse of the moving grip of 500 mm/min \pm 50 mm/min.

4.2 Die, for cutting out the test piece. The construction of the die and the knife which cuts the slit are shown in Figures 1 and 2.

4.3 Micrometer gauge, complying with the requirements of ISO 23529 and having a circular foot approximately 6 mm in diameter which exerts a pressure of $22 \text{ kPa} \pm 5 \text{ kPa}$.

4.4 Travelling microscope, giving at least $\times 10$ magnification, fitted with a graticule graduated at 0,01 mm intervals.

5 Calibration

The requirements for calibration of the test apparatus are given in Annex B.

6 Test pieces

6.1 Shape and dimensions

The test pieces shall be rectangular and shall conform to the dimensions shown in Figure 3 and Table 1.

The test pieces shall be cut from a sheet by punching with the die (4.2), using a single blow of a mallet or (preferably) a single stroke of a press. The rubber may be wetted with water or a soap solution, and shall be supported on a sheet of slightly yielding material (for example leather, rubber belting or cardboard) on a flat, rigid surface.

The tear strength is particularly susceptible to grain effects in the rubber. Normally, all test pieces are prepared with the grain at right angles to their length, but, in cases where grain effects are significant and are to be evaluated, two sets of test pieces shall be cut from the sheet, one at right angles to the grain and the other parallel to the grain.

The thickness d of the test pieces shall be $2,0 \text{ mm} \pm 0,2 \text{ mm}$.

6.2 Measurement of dimensions

6.2.1 Measurement of thickness

Measure the thickness of the test piece by method A of ISO 23529:2010. Take at least three gauge readings in the region of the slit. If an even number of readings is taken, use the average of the two median values as the result. If an odd number of readings is taken, use the median value. No reading shall deviate by more than 2 % from the value used. When the test results are to be used for comparative purposes, the thickness of any test piece shall not vary by more than 10 % from the mean thickness of all the test pieces.

Dimensions in millimetres

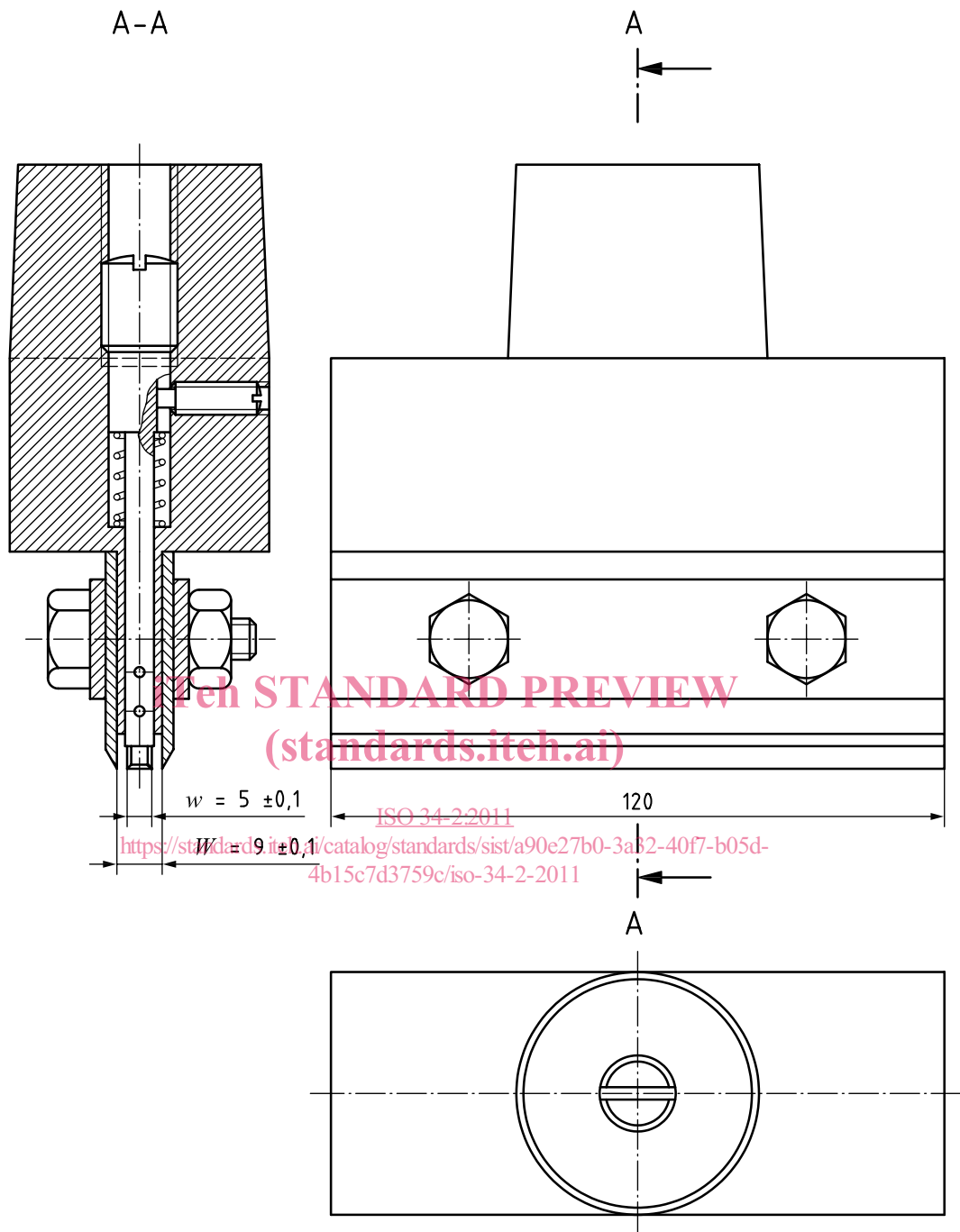

$b_3 = W - w$ (method 2)

Figure 1 — Die for Delft test pieces

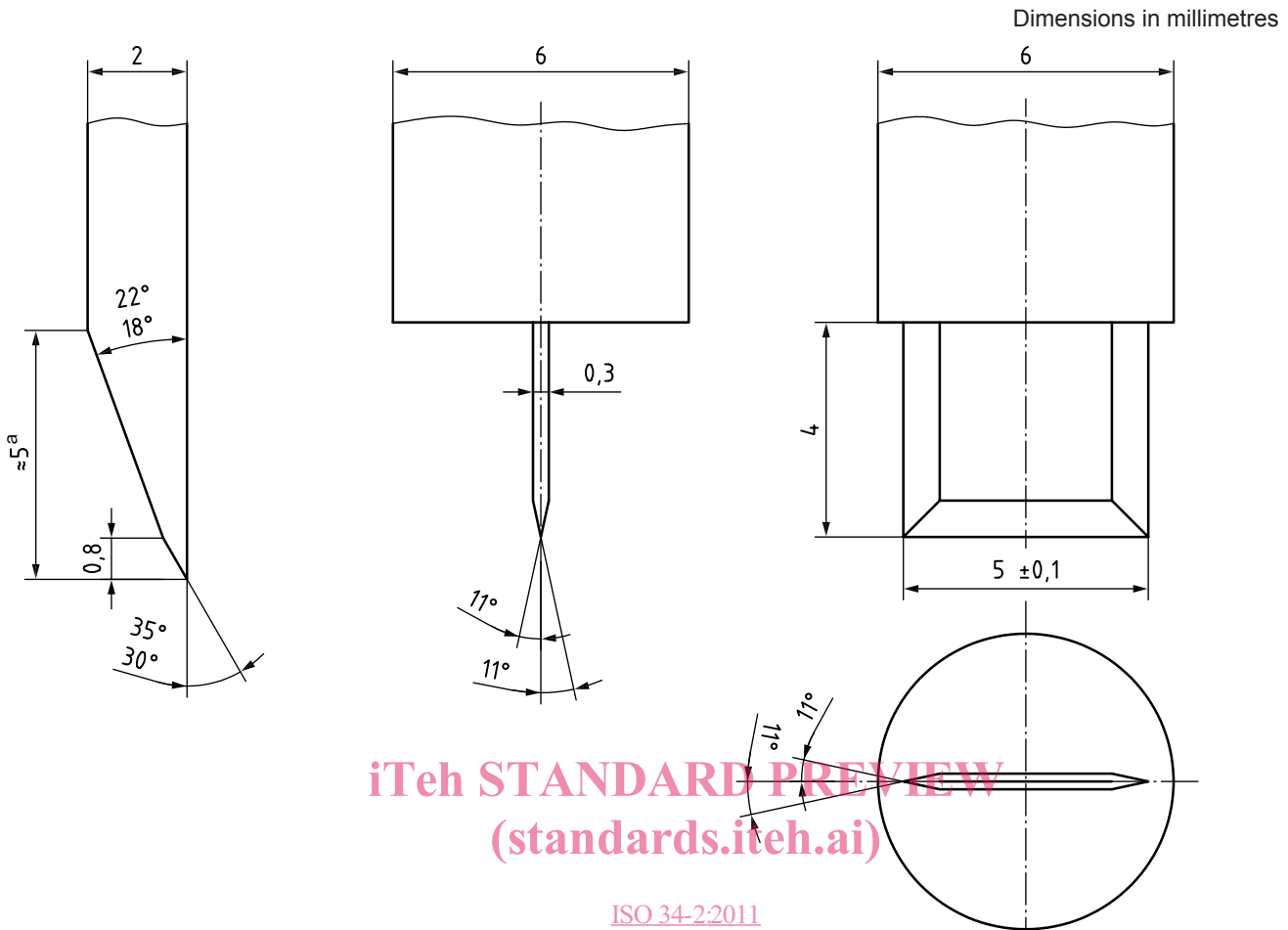

iTeh STANDARD PREVIEW
(standards.iteh.ai)

ISO 34-2:2011

<https://standards.iteh.ai/catalog/standards/sist/a90e27b0-3a32-40f7-b05d-4b15c7d3759c/iso-34-2-2011>

a) Enlarged detail of blade for cutting out test piece

b) Enlarged detail of small blade for cutting slit

a Cutting edge.

Figure 2 — Details of Delft test piece die cutting edges

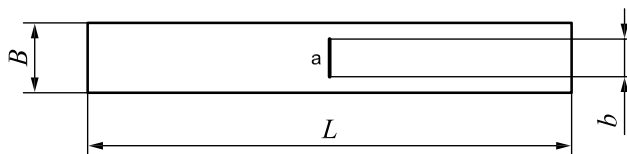

a Slit to be symmetrical with the width.

Figure 3 — Test piece

Table 1 — Dimensions of test piece

Dimension		Value mm
<i>L</i>	Length	60
<i>B</i>	Width	$9,0 \pm 0,1$
<i>b</i>	Slit length	$5,0 \pm 0,1$

6.2.2 Measurement of the total width outside the slit

6.2.2.1 General

The total width outside the slit b_3 corresponds to the rubber to be torn.

Two methods of measurement may be used. Method 1 is theoretically more exact, but is difficult to use in practice. Method 2, which is in common use, is simpler but can give different results. Unless otherwise specified, use method 2.

Results obtained using test pieces measured by different methods shall not be compared.

6.2.2.2 Method 1: Measurement by travelling microscope

Variations occur in the length of the slit and in the total width of the test piece when the same die is used to prepare test pieces from rubber of different hardnesses. Moreover, the slit might not be uniform throughout its depth, but might be wider at one surface. Take one test piece which has been cut out with the die, therefore, and use it to measure the width to be torn by cutting the test piece through with a sharp razor blade in the plane of the slit and measuring the cut surfaces (width on either side of the slit) with a travelling microscope. The ends of the slit are curved as shown in Figure 4, and an attempt shall be made to allow for this curvature when measuring the width on either side of the slit, as follows.

Take as the width on the left-hand side b_1 , which is the distance from the line AB to an imaginary line A'B' which is situated so that the total area $S_1 + S_2 = S_3$.

Similarly, on the right-hand side, imagine a line C'D' situated so that the total area $S_1' + S_2' = S_3'$ and b_2 is the width.

The total width b_3 outside the slit (i.e. the rubber to be torn) is then $b_1 + b_2$.

Dimensions in millimetres

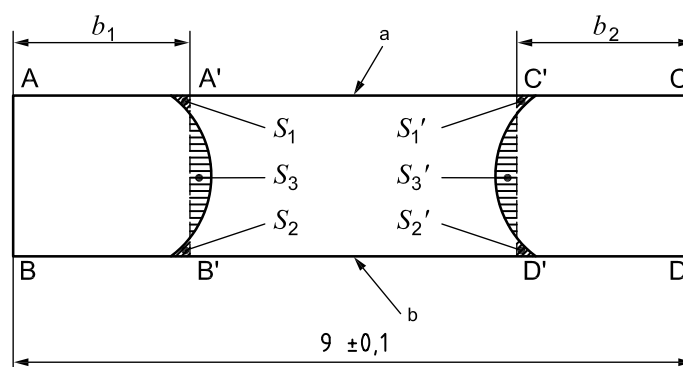

$$b_3 = b_1 + b_2 \text{ (method 1)}$$

- a Top.
- b Bottom.

Figure 4 — Section through slit in Delft test piece