



Designation: ~~D2170-01a(Reapproved 2006)~~ Designation: D 2170 – 07



Designation: 319/84 (89)

Standard Test Method for Kinematic Viscosity of Asphalts (Bitumens)¹

This standard is issued under the fixed designation D 2170; the number immediately following the designation indicates the year of original adoption or, in the case of revision, the year of last revision. A number in parentheses indicates the year of last reapproval. A superscript epsilon (ϵ) indicates an editorial change since the last revision or reapproval.

This standard has been approved for use by agencies of the Department of Defense.

1. Scope

1.1 This test method covers procedures for the determination of kinematic viscosity of liquid asphalts (bitumens), road oils and distillation residues of liquid asphalts (bitumens) all at 60°C (140°F) and of asphalt cements at 135°C (275°F) (Note 1) in the range from 6 to 100 000 mm²/s (cSt).

1.2 Results of this test method can be used to calculate viscosity when the density of the test material at the test temperature is known or can be determined. See Annex A1 for the method of calculation.

NOTE 1—This test method is suitable for use at other temperatures and at lower kinematic viscosities, but the precision is based on determinations on liquid asphalts and road oils at 60°C (140°F) and on asphalt cements at 135°C (275°F) only in the viscosity range from 30 to 6000 mm²/s (cSt).

1-3

1.3 **Warning**—Mercury has been designated by United States Environmental Protection Agency (EPA) and many state agencies as a hazardous material that can cause central nervous system, kidney and liver damage. Mercury, or its vapor, may be hazardous to health and corrosive to materials. Caution should be taken when handling mercury and mercury containing products. See the applicable product Material Safety Data Sheet (MSDS) for details and EPA's website—<http://www.epa.gov/mercury/faq.htm>—for additional information. Users should be aware that selling mercury, mercury containing products, or both, in your state may be prohibited by state law.

1.4 *This standard does not purport to address all of the safety concerns, if any, associated with its use. It is the responsibility of the user of this standard to establish appropriate safety and health practices and determine the applicability of regulatory limitations prior to use.*

2. Referenced Documents

2.1 *ASTM Standards:*²

- C 670 Practice for Preparing Precision and Bias Statements for Test Methods for Construction Materials
- D 92 Test Method for Flash and Fire Points by Cleveland Open Cup Tester
- D 341 Test Method for Viscosity-Temperature Charts for Liquid Petroleum Products
- D 445 Test Method for Kinematic Viscosity of Transparent and Opaque Liquids (and Calculation of Dynamic Viscosity)
- D 446 Specifications and Operating Instructions for Glass Capillary Kinematic Viscometers
- D 2162 Practice for Basic Calibration of Master Viscometers and Viscosity Oil Standards
- D 2493 Standard Viscosity-Temperature Chart for Asphalts
- E 1 Specification for ASTM Liquid-in-Glass Thermometers
- E 77 Test Method for Inspection and Verification of Thermometers

3. Terminology

3.1 *Definitions:*

3.1.1 *density*—the mass per unit volume of liquid and the cgs unit of density is 1 g/cm³. The SI unit of density is 1 kg/m³.

¹ This test method is under the jurisdiction of ASTM Committee D04 on Road and Paving Materials and is the direct responsibility of Subcommittee D04.44 on Rheological Tests. In the IP this test method is under the jurisdiction of the Standardization Committee.

Current edition approved Dec. 1, 2006-2007. Published December 2006-2007. Originally approved in 1963. Last previous edition approved in 2002-2006 as D 2170 – 01a (2006).

² For referenced ASTM standards, visit the ASTM website, www.astm.org, or contact ASTM Customer Service at service@astm.org. For *Annual Book of ASTM Standards* volume information, refer to the standard's Document Summary page on the ASTM website.

3.1.2 *kinematic viscosity*—the ratio of the viscosity to the density of a liquid. It is a measure of the resistance to flow of a liquid under gravity. The SI unit of kinematic viscosity is m^2/s ; for practical use, a submultiple (mm^2/s) is more convenient. The cgs unit of kinematic viscosity is $1 \text{ cm}^2/\text{s}$ and is called a stokes (symbol St). The centistokes ($1 \text{ cSt} = 10^{-2} \text{ St}$) is $1 \text{ mm}^2/\text{s}$ and is often used.

3.1.3 *Newtonian liquid*—a liquid in which the rate of shear is proportional to the shearing stress. The constant ratio of the shearing stress to the rate of shear is the viscosity of the liquid. If the ratio is not constant, the liquid is non-Newtonian.

3.1.4 *viscosity*—the ratio between the applied shear stress and rate of shear is called the coefficient of viscosity. This coefficient is a measure of the resistance to flow of a liquid. It is commonly called the viscosity of the liquid. The cgs unit of viscosity is $1 \text{ g/cm}\cdot\text{s}$ ($1 \text{ dyne}\cdot\text{s/cm}^2$) and is called a poise (P). The SI unit of viscosity is $1 \text{ Pa}\cdot\text{s}$ ($1 \text{ N}\cdot\text{s/m}^2$) and is equivalent to 10 P.

4. Summary of Test Method

4.1 The time is measured for a fixed volume of the liquid to flow through the capillary of a calibrated glass capillary viscometer under an accurately reproducible head and at a closely controlled temperature. The kinematic viscosity is then calculated by multiplying the efflux time in seconds by the viscometer calibration factor.

5. Significance and Use

5.1 The kinematic viscosity characterizes flow behavior. The method is used to determine the consistency of bitumen as one element in establishing the uniformity of shipments or sources of supply. The specifications are usually at temperatures of 60 and 135°C.

6. Apparatus

6.1 *Viscometers*, capillary-type, made of borosilicate glass, annealed, suitable for this test are described in Annex A2 and include the following:

6.1.1 *Cannon-Fenske viscometer for opaque liquids*,

6.1.2 *Zeitfuchs cross-arm viscometer*,

6.1.3 *Lantz-Zeitfuchs viscometer*,

6.1.4 *BS U-Tube modified reverse flow viscometer*.

6.2 6.2.1.5 Calibrated viscometers are available from commercial suppliers. Details regarding calibration of viscometers are given in Annex A3.

6.3

6.2 *Thermometers*—Calibrated liquid-in-glass thermometers of an accuracy after correction of 0.02°C (0.04°F) can be used or any other thermometric device of equal accuracy. ASTM Kinematic Viscosity Thermometers 47C and 47F conforming to Specification E 1, and IP 35C and 35F are suitable for use at 60°C (140°F) and ASTM Kinematic Viscosity Thermometers 110C and 110F are suitable for use at 135°C (275°F).

~~6.3.1~~ 6.2.1 The specified thermometers are standardized at “total immersion,” which means immersion to the top of the mercury column with the remainder of the stem and the expansion chamber at the top of the thermometer exposed to room temperature. The practice of completely submerging the thermometer is not recommended. When thermometers are completely submerged, corrections for each individual thermometer based on calibration under conditions of complete submergence must be determined and applied. If the thermometer is completely submerged in the bath during use, the pressure of the gas in the expansion chamber will be higher or lower than during standardization, and may cause high or low readings on the thermometer. Thermometric devices for this test method must be standardized at least every 6 months.

~~6.3.2~~ 6.2.2 It is essential that liquid-in-glass thermometers be calibrated periodically using the technique given in Test Method E 77 (see Appendix X1).

6.4

6.3 *Bath*—A bath suitable for immersion of the viscometer so that the liquid reservoir or the top of the capillary, whichever is uppermost, is at least 20 mm below the upper bath level, and with provisions for visibility of the viscometer and the thermometer. Firm supports for the viscometer shall be provided, or the viscometer may be an integral part of the bath. The efficiency of the stirring and the balance between heat losses and heat input must be such that the temperature of the bath medium does not vary by more than $\pm 0.03^\circ\text{C}$ ($\pm 0.05^\circ\text{F}$) over the length of the viscometer, or from viscometer to viscometer in the various bath positions at 60°C (140°F). The variation at 135°C (275°F) must not exceed $\pm 0.03^\circ\text{C}$ ($\pm 0.05^\circ\text{F}$).

NOTE 2—Distilled water is a suitable bath liquid for determinations at 60°C (140°F). USP White Oil with a flash point above 215°C (420°F) has been found suitable for determinations at 135°C (275°F). The flash point is determined in accordance with Test Method D 92.

6.5

6.4 *Timer*—~~A stop watch or other spring-activated timing device graduated in divisions of 0.1 s or less and accurate to within 0.05% when tested over intervals of not less than 15 min.~~

~~6.6—A stop watch or other timing device graduated in divisions of 0.1 s or less and accurate to within 0.05 % when tested over intervals of not less than 15 min. Timing devices for this test method must be calibrated at least every 6 months.~~

6.4.1 *Electrical Timing Devices* may be used only on electrical circuits the frequencies of which are controlled to an accuracy of 0.05 % or better.

6.64.1.1 Alternating currents, the frequencies of which are intermittently and not continuously controlled, as provided by some public power systems, can cause large errors, particularly over short timing intervals, when used to actuate electrical timing devices.

7. Preparation of Sample

7.1 To minimize loss of volatile constituents and to obtain reproducible results, proceed as follows:

7.1.1 *Procedure for Liquid Asphalt (Bitumen) and Road Oil:*

7.1.1.1 Allow sealed samples, as received, to reach room temperature.

7.1.1.2 Open the sample container and mix the sample thoroughly by stirring for 30 s taking care to avoid the entrapment of air. If the sample is too viscous for such stirring, place the sample in the tightly sealed container in a bath or oven maintained at $63 \pm 3^\circ\text{C}$ ($145 \pm 5^\circ\text{F}$) until it becomes sufficiently liquid for stirring.

7.1.1.3 Immediately charge the viscometer, or, if the test is to be made at a later time, pour approximately 20 mL into one or more clean, dry containers having a capacity of approximately 30 mL and immediately seal with an airtight closure.

7.1.1.4 For materials with kinematic viscosities at 60°C (140°F) above $800 \text{ mm}^2/\text{s}$ (cSt), heat the 20-mL sample in the sealed container in an oven or bath maintained at $63 \pm 3^\circ\text{C}$ ($145 \pm 5^\circ\text{F}$) until it is sufficiently liquid for a convenient transfer into the viscometer. Such heating should not exceed 30 min.

7.1.2 *Procedure for Asphalt Cement :*

7.1.2.1 Heat the sample with care to prevent local overheating until it has become sufficiently fluid to pour, occasionally stirring the sample to aid heat transfer and to assure uniformity.

7.1.2.2 Transfer a minimum of 20 mL into a suitable container and heat to $135 \pm 5.5^\circ\text{C}$ ($275 \pm 10^\circ\text{F}$), stirring occasionally to prevent local overheating and taking care to avoid the entrapment of air.

8. Procedure

8.1 The specific details of operation vary somewhat for the various types of viscometers. See the detailed descriptions of viscometers in Annex A2 for instructions for using the type of viscometer selected. In all cases, however, follow the general procedure described in 8.2 to 8.8.

8.2 Maintain the bath at the test temperature within $\pm 0.01^\circ\text{C}$ ($\pm 0.02^\circ\text{F}$) for test temperature of 60°C (140°F) and within $\pm 0.03^\circ\text{C}$ ($\pm 0.05^\circ\text{F}$) for test temperature of 135°C (275°F). Apply the necessary corrections, if any, to all thermometer readings.

8.3 Select a clean, dry viscometer which will give an efflux time greater than 60 s and preheat to test temperature.

8.4 Charge the viscometer in the manner dictated by the design of the instrument, as prescribed in Annex A2.

8.5 Allow the charged viscometer to remain in the bath long enough to reach the test temperature, as prescribed in Annex A2.

8.6 Start the flow of asphalt in the viscometer as prescribed in Annex A2.

8.7 Measure to within 0.1 s, the time required for the leading edge of the meniscus to pass from the first timing mark to the second. If this efflux time is less than 60 s, select a viscometer of smaller capillary diameter and repeat the operation.

8.8 Upon completion of the test, clean the viscometer thoroughly by several rinsings with an appropriate solvent completely miscible with the sample, followed by a completely volatile solvent. Dry the tube by passing a slow stream of filtered dried air

TABLE 1 Acceptability of Test Results for Kinematic Viscosity

NOTE 1—The values given in column 2 are the coefficients of variation that have been found to be appropriate for the materials and conditions of test described in column 1. The values given in column 3 are the limits that should not be exceeded by the difference between the results of two properly conducted tests.

Material and Type Index	Coefficient of Variation (% of mean) ^A	Acceptable Range of Two Results (% of mean) ^A
Single-operator precision:		
Asphalt cements at 135°C (275°F)	0.64	1.8
Liquid asphalts at 60°C (140°F):		
below $3000 \text{ mm}^2/\text{s}$ (cSt)	0.53	1.5
3000 to $6000 \text{ mm}^2/\text{s}$ (cSt)	0.71	2.0
$6000 \text{ mm}^2/\text{s}$ (cSt) and above	3.2	8.9
Multilaboratory precision:		
Asphalt cements at 135°C (275°F)	3.1	8.8
Liquid asphalts at 60°C (140°F):		
below $3000 \text{ mm}^2/\text{s}$ (cSt)	1.06	3.0
3000 to $6000 \text{ mm}^2/\text{s}$ (cSt) ^B	3.11	9.0
above $6000 \text{ mm}^2/\text{s}$ (cSt) ^B	3.6	10.0

^AThese numbers represent, respectively, the (1s %) and (d2s %) limits as described in Practice C 670.

^BBased on less than 30 degrees of freedom.

through the capillary for 2 min, or until the last trace of solvent is removed. Alternatively, the viscometer may be cleaned in a glass cleaning oven, at a temperature not to exceed 500°C (932°F), followed by rinses with distilled or deionized water, residue-free acetone, and filtered dry air. Periodically clean the instrument with a strong acid cleaning solution to remove organic deposits, rinse thoroughly with distilled water and residue-free acetone, and dry with filtered dry air.

NOTE 3—The cleaning oven may burn off the glue that connects the viscometer tube to the holder.

8.8.1 Chromic acid cleaning solution may be prepared by adding, with the usual precautions, 800 mL of concentrated sulphuric acid to a solution of 92 g of sodium dichromate in 458 mL of water. The use of similar commercially available sulphuric acid cleaning solutions is acceptable. Nonchromium-containing, strongly oxidizing acid cleaning solutions may be substituted so as to avoid the disposal problems of chromium-containing solutions.

8.8.2 Use of alkaline glass cleaning solutions may result in a change of viscometer calibration, and is not recommended.

9. Calculation

9.1 Calculate the kinematic viscosity to three significant figures using the following equation:

$$\text{Kinematic viscosity, mm}^2/\text{s (cSt)} = Ct \quad (1)$$

where:

C = calibration constant of the viscometer, mm^2/s^2 (cSt/s), and

t = efflux time, s.

NOTE 4—Other ASTM publications on viscosity that may be used in conjunction with results determined in accordance with this test method are Test Methods D 445, Standards D 341 and D 2493, Standard D 2493, and Specifications D 446.

10. Report

10.1 Always report the test temperature with the result, for example:

$$\text{Kinematic viscosity at } 60^\circ\text{C} = 75.6 \text{ mm}^2/\text{s (cSt)} \quad (2)$$

11. Precision—Precision and Bias

11.1 Criteria for judging the acceptability of viscosity test results obtained by this method are given in Table 1:

Document Preview

[ASTM D2170-07](https://standards.iteh.ai/catalog/standards/sist/e4c0af13-717b-4e8f-8ef3-85de2f4e01f6/astm-d2170-07)

<https://standards.iteh.ai/catalog/standards/sist/e4c0af13-717b-4e8f-8ef3-85de2f4e01f6/astm-d2170-07>

11.2 The bias of the procedure in this test method cannot be determined because no material having an accepted reference value is available.

12. Keywords

12.1 asphalt; capillary; kinematic; viscometer; viscosity

ANNEXES

(Mandatory Information)

A1. CALCULATION OF VISCOSITY OF A NEWTONIAN LIQUID

A1.1 The viscosity of a Newtonian liquid is calculated from its kinematic viscosity by multiplying the kinematic viscosity by the density of the liquid at the test temperature.

A1.2 For paving grade asphalts, density at 135°C (275°F) can be conveniently determined from specific gravity at 25/25°C (77/77°F) by multiplying by a factor of 0.934 g/cm³; or from the specific gravity at 15.5/15.5°C (60/60°F) by multiplying by a factor of 0.931 g/cm³. These factors are based on an average coefficient of expansion for asphalt cement of 0.00061/°C (0.00034/°F).

A1.3 When the specific gravity of the asphalt is not known, a satisfactory determination of the viscosity at 135°C (275°F) can be obtained by multiplying the kinematic viscosity at 135°C (275°F) by an assumed density of 0.948 g/cm³. This density value is equivalent to a specific gravity of 1.015 at 25/25°C (77/77°F). Tests on a large number of asphalts indicate that the error introduced by this assumed density will not exceed ±3 %.

A2. REVERSE-FLOW VISCOMETERS

A2.1 Scope

A2.1.1 The reverse-flow viscometers for transparent and opaque liquids include the Cannon-Fenske Opaque,³ Zeitfuchs Cross-Arm,⁴ BS/IP/RF, and Lantz-Zeitfuchs viscometers. Unlike the modified Ostwald and suspended-level viscometers, the sample of liquid flows into a timing bulb not previously wet by sample, thus allowing the timing of liquids whose thin films are opaque. Reverse-flow viscometers are used for the measurement of kinematic viscosities of opaque and transparent liquids up to 100 000 mm²/s (cSt).

A2.2 Apparatus

A2.2.1 For the reverse-flow viscometers, detailed drawings of the size designations, approximate constants, kinematic viscosity range, capillary diameter, and bulb volumes for each viscometer are shown in Figs. A2.1-A2.4. The kinematic viscosity range is based on a 60-s minimum flow-time in this method; the same viscometers are also described in Specifications D 446 with a different viscosity range based on a 200-s minimum flow-time as prescribed in Test Method D 445. The lengths of the upper tubes K, L, M and N in Figs. A2.1-A2.4 may be increased (or decreased) to conform to the immersion requirements of 6.46.3.

A2.3 Operating Instructions

A2.3.1 A standard operating procedure is contained in Section 7. Additional operating instructions for the reverse-flow viscometers are outlined in A2.3.2-A2.3.8 with emphasis on procedures that are specific to a particular instrument or this group of instruments.

A2.3.2 Select a clean, dry viscometer that will give a flow time greater than 60 s.

A2.3.3 Charge the viscometer in the manner dictated by the design of the instrument, this operation being in conformity with that employed when the instrument was calibrated. If the sample may contain lint, solid particles, etc., filter as prescribed in Test Method D 445.

A2.3.3.1 To charge the Cannon-Fenske Opaque viscometer, invert the viscometer and apply suction to the tube *L*, immersing tube *N* in the liquid sample. Draw liquid through tube *N*, filling bulb *D* to fill mark *G*. Wipe excess sample off tube *N* and invert the viscometer to its normal position. Mount the viscometer in the constant-temperature bath, keeping tube *L* vertical.

² A commercial source for nonchromium-containing cleaning solution is Godax Laboratories, Inc., 480 Canal St., New York, NY 10013. If you are aware of alternative suppliers, please provide this information to ASTM International Headquarters. Your comments will receive careful consideration at a meeting of the responsible technical committee, which you may attend.

³ Cannon, M. R., and Fenske, M. R., "Viscosity Measurement—Opaque Liquids," *Industrial and Engineering Chemistry*, Analytical Edition, Vol 13, 1941, p. 2910.

⁴ Cannon, M. R., and Fenske, M. R., "Viscosity Measurement—Opaque Liquids," *Industrial and Engineering Chemistry*, Analytical Edition, Vol 13, 1941, p. 2910.

⁴ Zeitfuchs, E. H., "Kinematic Viscometer for Opaque and Very Viscous Liquids," *Oil and Gas Journal*, Vol 44, No. 36, 1946, p. 98.

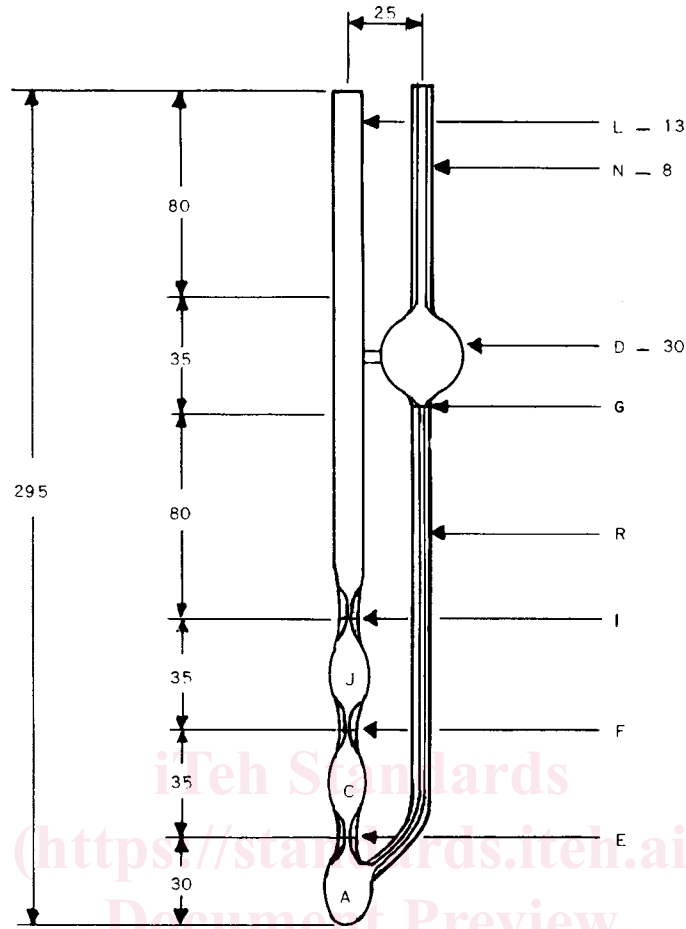

NOTE 1—All dimensions are in millimetres.

Dimensions and Kinematic Viscosity Ranges

Size No.	Approximate Constant, mm ² /s (cSt/s)	Kinematic Viscosity Range, mm ² /s (cSt)	Inside Diameter of Tube, R, mm (±2%)	Inside Diameter of Tube N and G Tubes E, F, and I, mm (±5%)	Volume Bulbs A, C, and J, mL (±5%)	Volume Bulb D, mL (±5%)
200	0.1	6 to 100	1.02	3.2	2.1	11
300	0.25	15 to 250	1.26	3.4	2.1	11
350	0.5	30 to 500	1.48	3.4	2.1	11
400	1.2	72 to 1200	1.88	3.4	2.1	11
450	2.5	150 to 2500	2.20	3.7	2.1	11
500	8	480 to 8000	3.10	4.0	2.1	11
600	20	1200 to 20 000	4.00	4.7	2.1	13

FIG. A2.1 Cannon-Fenske Opaque Viscometer for Opaque and Transparent Liquids

A2.3.3.2 Mount the Zeitfuchs Cross-Arm viscometer in the constant-temperature bath, keeping tube N vertical. Introduce sample through tube N taking care not to wet the sides of tube N, into the cross-arm D until the leading edge stands within 0.5 mm of fill mark G on the siphon tube.

NOTE A2.1—The volume of the test specimen is dependent on the location of the fill mark G. When the flow time of the lower meniscus is being measured between timing marks E and F, the upper meniscus shall be in the horizontal cross-arm D, thus making the location of fill mark G critical.

A2.3.3.3 Mount the Lantz-Zeitfuchs viscometer in the constant-temperature bath keeping tube N vertical. Introduce sufficient sample through tube N to completely fill bulb D, overflowing slightly into overflow bulb K. If the sample is poured at a temperature above test temperature, wait 15 min for the sample in the viscometer to attain bath temperature and add more sample to overflow slightly into bulb K.

A2.3.3.4 Mount the BS/IP/RF viscometer in the constant-temperature bath keeping tube L vertical. Pour sample through tube N to a point just above filling mark G; allow the sample to flow freely through capillary R, taking care that the liquid column remains unbroken, until the lower meniscus is about 5 mm below the filling mark H and then arrest its flow by closing the timing tube with a cork or rubber stopper in tube L. Add more liquid if necessary to bring the upper meniscus slightly above mark G. After allowing the sample to attain bath temperature (see A2.3.4) and any air bubbles to rise to the surface, gently loosen the stopper