



# SLOVENSKI STANDARD SIST ISO 730:2015/A1:2015

01-april-2015

Nadomešča:  
SIST ISO 730-1:1996

---

**Kmetijski kolesni traktorji - Zadnje tritočkovno priključno drogovje - Kategorije  
1N, 1, 2N, 2, 3N, 3, 4N in 4**

Agricultural wheeled tractors - Rear-mounted three-point linkage - Categories 1N, 1, 2N,  
2, 3N, 3, 4N and 4

**iTeh STANDARD PREVIEW**  
**(standards.iteh.ai)**

Tracteurs agricoles à roues - Attelage trois points monté à l'arrière - Catégories 1N, 1,  
2N, 2, 3N, 3, 4N et 4

[SIST ISO 730:2015/A1:2015](https://standards.iteh.ai/catalog/standards/sist/e5652a6c-3d09-44a7-aba9-7aebfa3750e7/sist-iso-730-2015-a1-2015)

<https://standards.iteh.ai/catalog/standards/sist/e5652a6c-3d09-44a7-aba9-7aebfa3750e7/sist-iso-730-2015-a1-2015>

**Ta slovenski standard je istoveten z: ISO 730:2009/Amd 1:2014**

---

**ICS:**

65.060.10      Kmetijski traktorji in prikolice      Agricultural tractors and  
trailed vehicles

**SIST ISO 730:2015/A1:2015**

**en,fr**

**iTeh STANDARD PREVIEW**  
**(standards.iteh.ai)**

[SIST ISO 730:2015/A1:2015](https://standards.iteh.ai/catalog/standards/sist/e5652a6c-3d09-44a7-aba9-7aebfa3750e7/sist-iso-730-2015-a1-2015)

<https://standards.iteh.ai/catalog/standards/sist/e5652a6c-3d09-44a7-aba9-7aebfa3750e7/sist-iso-730-2015-a1-2015>

INTERNATIONAL  
STANDARD

ISO  
730

First edition  
2009-01-15

**AMENDMENT 1**  
2014-07-01

---

---

**Agricultural wheeled tractors —  
Rear-mounted three-point linkage —  
Categories 1N, 1, 2N, 2, 3N, 3, 4N and 4  
AMENDMENT 1**

*Tracteurs agricoles à roues — Attelage trois points monté à l'arrière  
— Catégories 1N, 1, 2N, 2, 3N, 3, 4N et 4*

iTeh STANDARD PREVIEW  
(standards.iteh.ai)

AMENDEMENT 1

SIST ISO 730:2015/A1:2015

<https://standards.iteh.ai/catalog/standards/sist/e5652a6c-3d09-44a7-aba9-7aebfa3750e7/sist-iso-730-2015-a1-2015>



Reference number  
ISO 730:2009/Amd.1:2014(E)

© ISO 2014

**iTeh STANDARD PREVIEW**  
**(standards.iteh.ai)**

[SIST ISO 730:2015/A1:2015](https://standards.iteh.ai/catalog/standards/sist/e5652a6c-3d09-44a7-aba9-7aebfa3750e7/sist-iso-730-2015-a1-2015)

<https://standards.iteh.ai/catalog/standards/sist/e5652a6c-3d09-44a7-aba9-7aebfa3750e7/sist-iso-730-2015-a1-2015>



**COPYRIGHT PROTECTED DOCUMENT**

© ISO 2014

All rights reserved. Unless otherwise specified, no part of this publication may be reproduced or utilized otherwise in any form or by any means, electronic or mechanical, including photocopying, or posting on the internet or an intranet, without prior written permission. Permission can be requested from either ISO at the address below or ISO's member body in the country of the requester.

ISO copyright office  
Case postale 56 • CH-1211 Geneva 20  
Tel. + 41 22 749 01 11  
Fax + 41 22 749 09 47  
E-mail [copyright@iso.org](mailto:copyright@iso.org)  
Web [www.iso.org](http://www.iso.org)

Published in Switzerland

## Foreword

ISO (the International Organization for Standardization) is a worldwide federation of national standards bodies (ISO member bodies). The work of preparing International Standards is normally carried out through ISO technical committees. Each member body interested in a subject for which a technical committee has been established has the right to be represented on that committee. International organizations, governmental and non-governmental, in liaison with ISO, also take part in the work. ISO collaborates closely with the International Electrotechnical Commission (IEC) on all matters of electrotechnical standardization.

The procedures used to develop this document and those intended for its further maintenance are described in the ISO/IEC Directives, Part 1. In particular the different approval criteria needed for the different types of ISO documents should be noted. This document was drafted in accordance with the editorial rules of the ISO/IEC Directives, Part 2 (see [www.iso.org/directives](http://www.iso.org/directives)).

Attention is drawn to the possibility that some of the elements of this document may be the subject of patent rights. ISO shall not be held responsible for identifying any or all such patent rights. Details of any patent rights identified during the development of the document will be in the Introduction and/or on the ISO list of patent declarations received (see [www.iso.org/patents](http://www.iso.org/patents)).

Any trade name used in this document is information given for the convenience of users and does not constitute an endorsement.

For an explanation on the meaning of ISO specific terms and expressions related to conformity assessment, as well as information about ISO's adherence to the WTO principles in the Technical Barriers to Trade (TBT) see the following URL: Foreword - Supplementary information

Amendment 1 to ISO 730:2009 was prepared by Technical Committee ISO/TC 23, *Tractors and machinery for agriculture and forestry*, Subcommittee SC 4, *Tractors*.

[SIST ISO 730:2015/A1:2015  
https://standards.iteh.ai/catalog/standards/sist/e5652a6c-3d09-44a7-aba9-7aebfa3750e7/sist-iso-730-2015-a1-2015](https://standards.iteh.ai/catalog/standards/sist/e5652a6c-3d09-44a7-aba9-7aebfa3750e7/sist-iso-730-2015-a1-2015)

**iTeh STANDARD PREVIEW**  
**(standards.iteh.ai)**

[SIST ISO 730:2015/A1:2015](https://standards.iteh.ai/catalog/standards/sist/e5652a6c-3d09-44a7-aba9-7aebfa3750e7/sist-iso-730-2015-a1-2015)

<https://standards.iteh.ai/catalog/standards/sist/e5652a6c-3d09-44a7-aba9-7aebfa3750e7/sist-iso-730-2015-a1-2015>

# Agricultural wheeled tractors — Rear-mounted three-point linkage — Categories 1N, 1, 2N, 2, 3N, 3, 4N and 4

## AMENDMENT 1

Page 7, [Figure 2](#)

Replace the present [Figure 2](#) by the following [Figure 2](#):

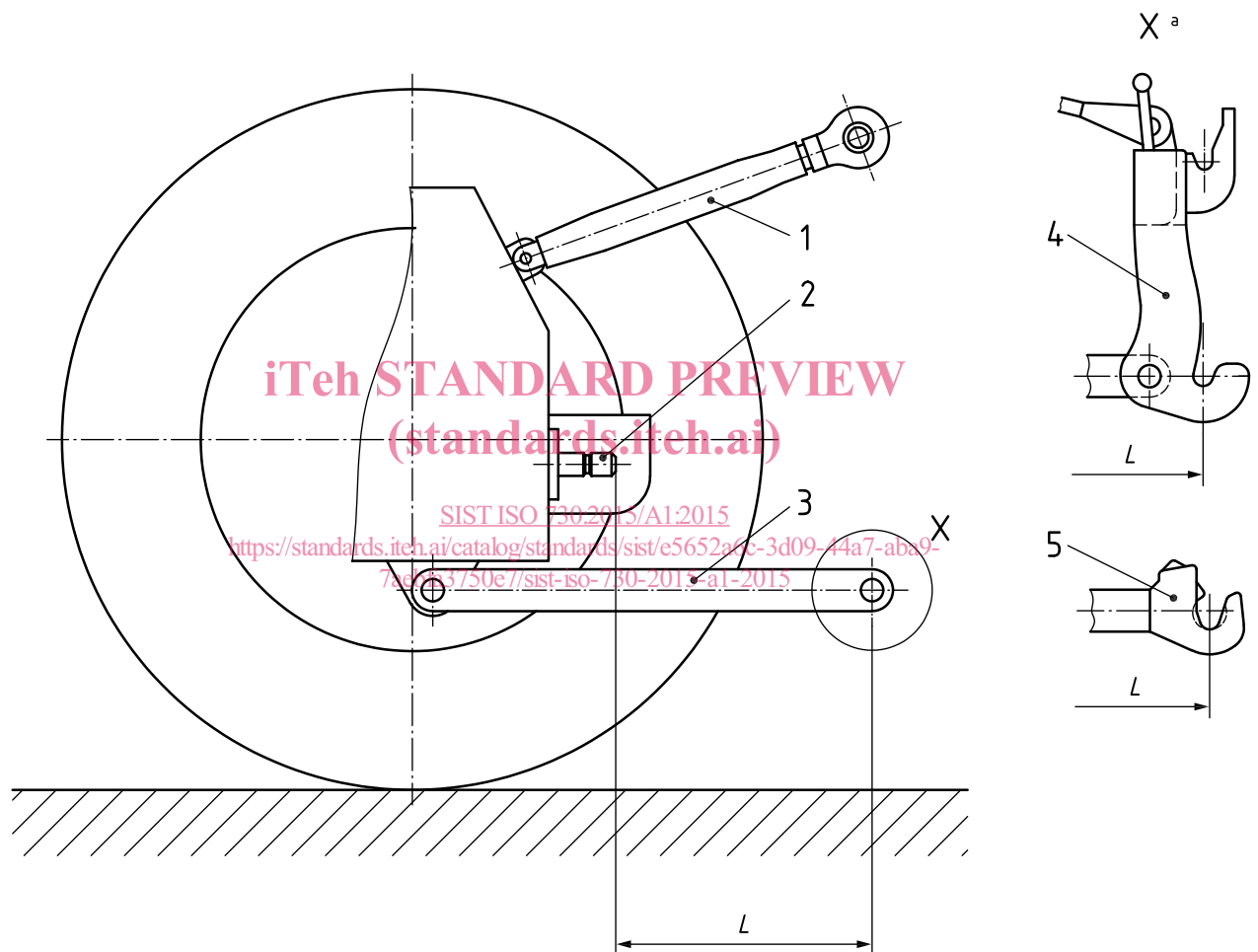

### Key

- |   |  |
|---|--|
| 1 | upper link                               |
| 2 | PTO                                      |
| 3 | lower links                              |
| X |  |
| 4 | U frame coupler according to ISO 11001-1 |
| 5 | Link coupler according to ISO 11001-3    |

NOTE Dimension L is given in [Table 2](#).

**Figure 2 — Distance from PTO to lower link points**

## ISO 730:2009/Amd.1:2014(E)

Page 9, Table 2

Replace the present Table 2 by the following Table 2:

Table 2 — Dimensions concerning tractor linkage points

Dimension	Description	See	Category							
			1N	1	2N	2	3N	3	4N	4
<b>Upper hitch points</b>										
$d_1$	Diameter of hitch pin hole	3	19,3 <sup>+0,2</sup> <sub>0</sub>	19,3 <sup>+0,2</sup> <sub>0</sub>	25,7 <sup>+0,2</sup> <sub>0</sub>	25,7 <sup>+0,2</sup> <sub>0</sub>	32 <sup>+0,25</sup> <sub>0</sub>	32 <sup>+0,25</sup> <sub>0</sub>	45,2 <sup>+0,3</sup> <sub>0</sub>	45,2 <sup>+0,3</sup> <sub>0</sub>
$B_1$	Width of ball	3	44 <sup>0</sup> <sub>-0,5</sub>	44 <sup>0</sup> <sub>-0,5</sub>	51 <sup>0</sup> <sub>-0,5</sub>	51 <sup>0</sup> <sub>-0,5</sub>	51 <sup>0</sup> <sub>-0,5</sub>	51 <sup>0</sup> <sub>-0,5</sub>	64 <sup>0</sup> <sub>-0,5</sub>	64 <sup>0</sup> <sub>-0,5</sub>
<b>Lower hitch points</b>										
$d_2$	Diameter of hitch pin hole	3	22,4 <sup>+0,25</sup> <sub>0</sub>	22,4 <sup>+0,25</sup> <sub>0</sub>	28,7 <sup>+0,3</sup> <sub>0</sub>	28,7 <sup>+0,3</sup> <sub>0</sub>	37,4 <sup>+0,35</sup> <sub>0</sub>	37,4 <sup>+0,35</sup> <sub>0</sub>	51 <sup>+0,5</sup> <sub>0</sub>	51 <sup>+0,5</sup> <sub>0</sub>
$B_3$	Width of ball	3	35 <sup>0</sup> <sub>-0,5</sub>	35 <sup>0</sup> <sub>-0,5</sub>	45 <sup>0</sup> <sub>-0,5</sub>	45 <sup>0</sup> <sub>-0,5</sub>	45 <sup>0</sup> <sub>-0,5</sub>	45 <sup>0</sup> <sub>-0,5</sub>	57,5 <sup>0</sup> <sub>-0,5</sub>	57,5 <sup>0</sup> <sub>-0,5</sub>
$l_1$	Lateral distance from lower hitch point to centreline of tractor <sup>a</sup>	3	218	359	364	435	435	505	505 <sup>b</sup>	612
$l_2$	Lateral movement of lower hitch point <sup>c</sup>	3	50 min.	100 min. <sup>d</sup>	100 min. <sup>d</sup>	125 min.	125 min.	125 min.	125 min.	125 min.
<p>a It could be necessary to vary these dimensions in case of specialized implements.</p> <p>b If U-frame couplers according to ISO 11001-1 are used, dimension <math>l_1</math> shall be 489 mm.</p> <p>c Values may be reduced by a maximum of 35 mm in certain applications (e.g. for wagon hitches (e.g. ISO 6489-2) or with wide tyre sizes).</p> <p>d If the tractor has a track width <math>\leq 1150</math> mm, this value may be reduced to 50 mm min.</p> <p>e For tractors designed with U- frame couplers as defined by ISO 11001-1 as standard equipment the lower links should be shortened so that the distance to the lower U-frame coupler jaw falls within the range for dimension L specified in ISO 730. See Figure 2. For tractors that offer U-frame couplers as an option, the lower links should be designed to the minimum L dimension given in ISO 730 as far as possible to minimize the distance that the combined lower link and U-frame coupler length (Lower socket offset) is over the upper limit of the L dimension range given in Table 2.</p>										