Road vehicles — Fuse-links —

Part 3:

Fuse-links with tabs (blade type) Type C (medium), Type E (high current) and Type F (miniature)

iTeh STANDARD PREVIEW
Véhicules routiers — Liaisons fusibles —

(standards.iteh.ai)
Partie 3: Liaisons fusibles cavalier (Type à lame), Type C (moyen), Type E (courant élevé) et Type F (miniature)

ISO 8820-3:2015

<https://standards.iteh.ai/catalog/standards/sist/54acb12d-a6bd-4b11-b075-a1cac7a25758/iso-8820-3-2015>



iTeh STANDARD PREVIEW
(standards.iteh.ai)

ISO 8820-3:2015

<https://standards.iteh.ai/catalog/standards/sist/54acb12d-a6bd-4b11-b075-a1cac7a25758/iso-8820-3-2015>



COPYRIGHT PROTECTED DOCUMENT

© ISO 2015, Published in Switzerland

All rights reserved. Unless otherwise specified, no part of this publication may be reproduced or utilized otherwise in any form or by any means, electronic or mechanical, including photocopying, or posting on the internet or an intranet, without prior written permission. Permission can be requested from either ISO at the address below or ISO's member body in the country of the requester.

ISO copyright office
Ch. de Blandonnet 8 • CP 401
CH-1214 Vernier, Geneva, Switzerland
Tel. +41 22 749 01 11
Fax +41 22 749 09 47
copyright@iso.org
www.iso.org

Contents

	Page
Foreword	iv
1 Scope	1
2 Normative references	1
3 Terms and definitions	1
4 Marking, labelling, and colour coding	1
5 Tests and requirements	2
5.1 General.....	2
5.1.1 Test criteria.....	2
5.1.2 Test sequence.....	3
5.2 Voltage drop.....	3
5.2.1 Tests.....	3
5.2.2 Requirements.....	4
5.3 Transient current cycling.....	5
5.3.1 Test.....	5
5.3.2 Requirements.....	6
5.4 Environmental conditions.....	6
5.5 Operating time-rating.....	6
5.5.1 Test.....	6
5.5.2 Requirement.....	6
5.6 Current steps.....	7
5.6.1 Test.....	7
5.6.2 Requirement.....	7
5.7 Breaking capacity.....	7
5.7.1 Test.....	7
5.7.2 Requirement.....	9
5.8 Strength of terminals.....	9
5.8.1 Test.....	10
5.8.2 Requirements.....	10
5.9 Test cable sizes.....	10
5.10 Temperature rise.....	11
6 Dimensions	12
6.1 Fuse-links Types C, E, and F.....	12
6.2 Designation example.....	15
Annex A (informative) Temperature rise test	16
Bibliography	17

Foreword

ISO (the International Organization for Standardization) is a worldwide federation of national standards bodies (ISO member bodies). The work of preparing International Standards is normally carried out through ISO technical committees. Each member body interested in a subject for which a technical committee has been established has the right to be represented on that committee. International organizations, governmental and non-governmental, in liaison with ISO, also take part in the work. ISO collaborates closely with the International Electrotechnical Commission (IEC) on all matters of electrotechnical standardization.

The procedures used to develop this document and those intended for its further maintenance are described in the ISO/IEC Directives, Part 1. In particular the different approval criteria needed for the different types of ISO documents should be noted. This document was drafted in accordance with the editorial rules of the ISO/IEC Directives, Part 2 (see www.iso.org/directives).

Attention is drawn to the possibility that some of the elements of this document may be the subject of patent rights. ISO shall not be held responsible for identifying any or all such patent rights. Details of any patent rights identified during the development of the document will be in the Introduction and/or on the ISO list of patent declarations received (see www.iso.org/patents).

Any trade name used in this document is information given for the convenience of users and does not constitute an endorsement.

For an explanation on the meaning of ISO specific terms and expressions related to conformity assessment, as well as information about ISO's adherence to the WTO principles in the Technical Barriers to Trade (TBT) see the following URL: [Foreword - Supplementary information \(standards.iteh.ai\)](http://Foreword - Supplementary information (standards.iteh.ai))

The committee responsible for this document is ISO/TC 22, *Road vehicles*, Subcommittee SC 32, *Electrical and electronic components and general system aspects*.

This fourth edition cancels and replaces the third edition (ISO 8820-3:2010), which has been technically revised.

ISO 8820 consists of the following parts, under the general title *Road vehicles — Fuse-links*:

- *Part 1: Definitions and general test requirements*
- *Part 2: User guidelines*
- *Part 3: Fuse-links with tabs (blade type) Type C (medium), Type E (high current) and Type F (miniature)*
- *Part 4: Fuse-links with female contacts (Type A) and bolt-in contacts (Type B) and their test fixtures*
- *Part 5: Fuse-links with axial terminals (Strip fuse-links) Types SF 30 and SF 51 fixtures*
- *Part 6: Single-bolt fuse-links*
- *Part 7: Fuse-links with tabs (Type G) with rated voltage of 450 V*
- *Part 8: Fuse-links with bolt-in contacts (Type H and J) with rated voltage of 450 V*
- *Part 9: Fuse-links with shortened tabs (Type K)*
- *Part 10: Fuse-links with tabs Type L (high current miniature)*

Road vehicles — Fuse-links —

Part 3:

Fuse-links with tabs (blade type) Type C (medium), Type E (high current) and Type F (miniature)

1 Scope

This part of ISO 8820 specifies fuse-links with tabs (blade-type) Type C (medium), Type E (high current), and Type F (miniature) for use in road vehicles. It establishes, for these fuse-link types, the rated current, test procedures, performance requirements, and dimensions.

This part of ISO 8820 is applicable for fuse-links with a rated voltage of 32 V or 58 V, a current rating of ≤ 100 A, and a breaking capacity of 1 000 A intended for use in road vehicles.

This part of ISO 8820 is intended to be used in conjunction with ISO 8820-1 and ISO 8820-2. The numbering of its clauses corresponds to that of ISO 8820-1, whose requirements are applicable, except where modified by requirements particular to this part of ISO 8820.

iTeh STANDARD PREVIEW

2 Normative references (standards.iteh.ai)

The following documents, in whole or in part, are normatively referenced in this document and are indispensable for its application. For dated references, only the edition cited applies. For undated references, the latest edition of the referenced document (including any amendments) applies.

ISO 2768-1, *General tolerances — Part 1: Tolerances for linear and angular dimensions without individual tolerance indications*

ISO 8820-1, *Road vehicles — Fuse-links — Part 1: Definitions and general test requirements*

3 Terms and definitions

For the purposes of this document, the terms and definitions given in ISO 8820-1 apply.

4 Marking, labelling, and colour coding

See ISO 8820-1 and [Table 1](#).

Table 1 — Fuse-link colour coding

Current rating	Colour Type C, Type F	Colour Type E
A		
1	black	
2	grey	
3	violet	
4	pink	
5	tan/light brown	
7,5	brown	
10	red	
15	blue	
20	yellow	yellow
25	white ^a	grey or white ^a
30	green	green
35	dark green	dark green
40	orange	orange
50		red
60		blue
70		brown
80		white ^a or grey
100		violet

^a For transparent fuse bodies, "white" means no colour is added to the plastic material. Same colour is not allowed for 25 A and 80 A Type E.

5 Tests and requirements

5.1 General

5.1.1 Test criteria

In addition to carrying out the test procedures in accordance with ISO 8820-1, the following criteria apply.

Tests shall be performed following the test sequences in [Table 2](#).

The test fixtures for electrical tests shall be designed in accordance with [Figure 1](#). The connection resistance shall be $\leq 0,8$ m Ω for Type C (medium) and Type F (miniature) fuse-links and $\leq 0,35$ m Ω for Type E (high current) fuse-links to ensure the proper function of the test fixture.

Fuse-links according to this part of ISO 8820 shall provide for visible evidence of an open-fuse element.

5.1.2 Test sequence

Table 2 — Test sequence

No.	Test	(Sub)clause	Sample groups						
			1	2	3	4	5	6	7
1	Dimensions	Clause 6	X	X	X	—	—	—	—
2	Marking, labelling, and colour coding	Clause 4	X	X	X	X	X	X	X
3	Fuse-link voltage drop	5.2	X	X	X	—	—	—	—
4	Strength of terminals	5.8	X	X	X	—	—	—	—
5	Environmental conditions	Climatic load	—	—	—	X	—	—	—
6		Chemical load	—	—	—	—	X	—	—
7		Mechanical load	—	—	—	—	—	X	—
8	Transient current cycling	5.3	—	—	—	—	—	—	X
9	Fuse-link voltage drop	5.2	—	—	—	X	X	X	X
10	Current steps	5.6	—	—	X	—	—	—	—
11	Breaking capacity	5.7	X	—	—	—	—	—	—
12	Operating time rating test	I_R or $1,10 I_R^a$	—	X	—	X	X	X	X
		$1,35 I_R^a$	—	Y	—	Y	Y	Y	Y
		$1,60 I_R$	—	Y	—	Y	Y	Y	Y
		$2,00 I_R$	—	Y	—	Y	Y	Y	Y
		$3,50 I_R$	—	Y	—	Y	Y	Y	Y
		$6,00 I_R$	—	Y	—	Y	Y	Y	Y
13	Strength of terminals	5.8	X	X	X	X	X	X	X

NOTE 1 Each sample group shall contain a minimum of 10 fuse-links for each rated current rating.

NOTE 2 For the operating time rating tests marked “Y”, the sample groups 2, 4, 5, 6, and 7 shall be divided equally. These fuse-links are intended to be subjected to a single operating time-rating test only.

NOTE 3 A dash (—) indicates that the test is not required.

^a Not required for 100 A fuse-link.

5.2 Voltage drop

5.2.1 Tests

The voltage drop, U_{AB} , shall be measured at points A and B across the fuse-link tabs as shown in [Figure 1](#).

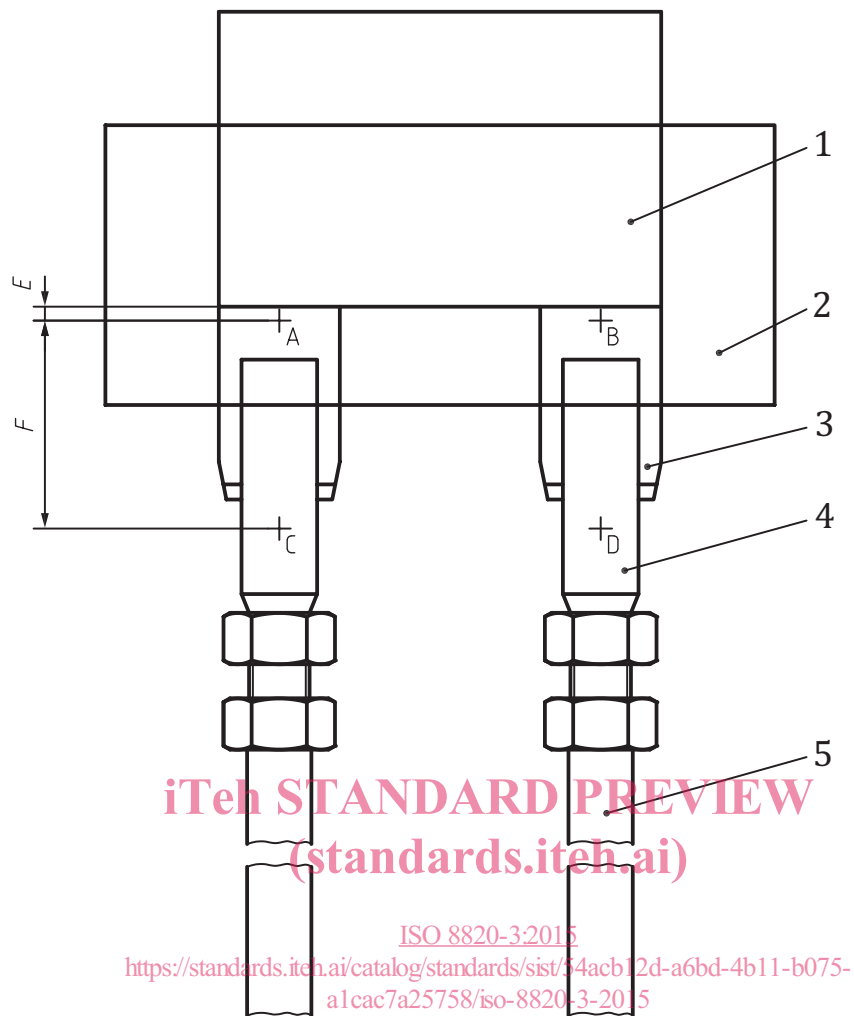

iTeh STANDARD PREVIEW
(standards.iteh.ai)

ISO 8820-3:2015

<https://standards.iteh.ai/catalog/standards/sist/54acb12d-a6bd-4b11-b075-a1cac7a25758/iso-8820-3-2015>

Key

- 1 fuse-link
- 2 test fixture
- 3 fuse blade
- 4 test clip (cantilevered contact system, receptacle to accept tabs as defined in [Table 7](#))
- 5 cable (size according to [Table 6](#))

E (1,5 ± 0,5) mm

F (15,5 ± 1) mm for miniature and medium fuse-links; (28,0 ± 1) mm for high current fuse-links

NOTE Points A and B are the measuring points for the voltage drop. Points A, C and B, D are the measuring points for connection resistance.

Figure 1 — Test schematic (Types C, E, and F)

5.2.2 Requirements

See [Table 3](#).

Table 3 — Voltage drop

Fuse rating A	Max. voltage drop U_{AB} mV
1	250
2	225
3	200
4	
5	175
7,5	150
10	140
15	125
20	
25	
30	120
35	
40	
50	
60	
70	
80	110
100	

iTeh STANDARD PREVIEW
(standards.iteh.ai)

ISO 8820-3:2015

5.3 Transient current cycling

<http://standards.iteh.ai/catalog/standards/sist/54acb12d-a6bd-4b11-b075-a1cac7a25758/iso-8820-3-2015>

5.3.1 Test

See [Figure 2](#) and ISO 8820-1. At an elapsed time of 0,025 s on-time, the current shall fall to a value between $1,65 I_R$ and $2,5 I_R$. At no time during the first 4,5 s of each cycle shall the steady-state current fall below $0,9 I_R$.

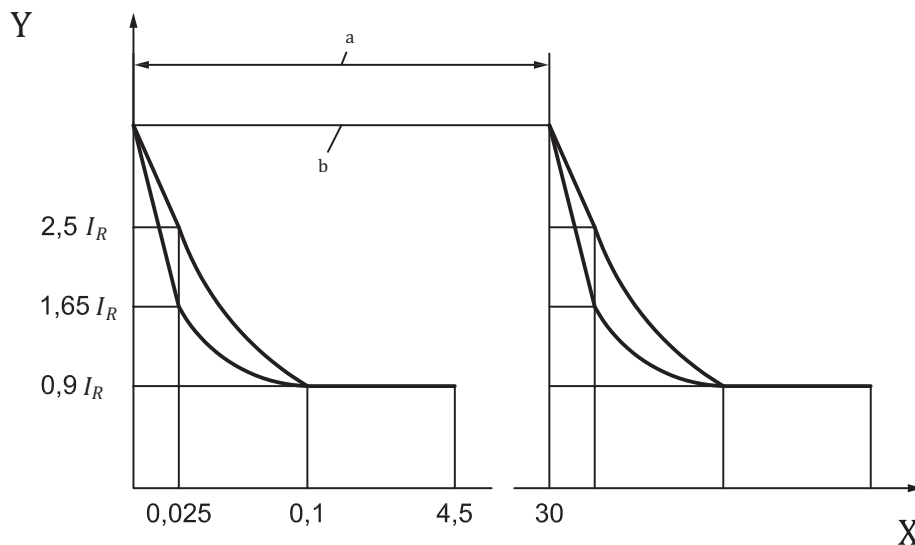

Key

X time (s)

Y current

a One cycle.

b (5,6 ... 6) I_R for $I_R > 5$ A; (4,6 ... 5) I_R for $I_R \leq 5$ A.

Figure 2 — Transient current cycling
(standards.iteh.ai)

5.3.2 Requirements

See ISO 8820-1.

[ISO 8820-3:2015](https://standards.iteh.ai/catalog/standards/sist/54acb12d-a6bd-4b11-b075-a1cac7a25758/iso-8820-3-2015)
<https://standards.iteh.ai/catalog/standards/sist/54acb12d-a6bd-4b11-b075-a1cac7a25758/iso-8820-3-2015>

5.4 Environmental conditions

See ISO 8820-1.

5.5 Operating time-rating

5.5.1 Test

See ISO 8820-1. For I_R , the test duration is 100 h.

5.5.2 Requirement

See [Table 4](#).

After activation, the current through the fuse-link shall not exceed 0,5 mA at the rated voltage of the fuse-link.

Table 4 — Operating times

Test current A	Operating time			
	s			
	Type C, F		Type E	
	min.	max.	min.	max.
I_R	—	—	360 000	∞
$1,1 I_R$	360 000	∞	—	—
$1,35 I_R^a$	0,75	600	60	900
$1,6 I_R$	0,25	50	10	200
$2,0 I_R$	0,15	5	2	60
$3,5 I_R$	0,04	0,5	0,2	7,0
$6 I_R$	0,02	0,1	0,04	1,0

NOTE A dash (—) indicates that no value is specified.

^a Not required for 100 A high current fuse-links.

5.6 Current steps

5.6.1 Test

See ISO 8820-1.

5.6.2 Requirement

See ISO 8820-1. After activation, the current through the fuse-link shall not exceed 0,5 mA at the rated voltage of the fuse-link.

5.7 Breaking capacity

5.7.1 Test

See ISO 8820-1.

Test at 1 000 A with cable sizes as shown in [Table 6](#).

Use an appropriate test dummy in accordance with [Figures 3](#) to [5](#).