



Designation: D 4675 – 00

Standard Guide for Selection and Use of Flat Strapping Materials¹

This standard is issued under the fixed designation D 4675; the number immediately following the designation indicates the year of original adoption or, in the case of revision, the year of last revision. A number in parentheses indicates the year of last reapproval. A superscript epsilon (ϵ) indicates an editorial change since the last revision or reapproval.

INTRODUCTION

This guide covers two common categories of strapping materials: flat carbon steel and nonmetallic strapping. Within each of these two broad categories, there are distinct types that lend themselves to particular applications to differing degrees.

The goal of this guide is to help the user focus on the desired elements of performance or service, and the unique properties of each strapping material in order to judge which of these strapping materials is best suited for the application. Contact your supplier for further information.

It is recognized that there are other materials (not covered) that may also offer acceptable solutions or may be used in conjunction with flat strapping. Also, examples of ancillary materials are shown in Fig. 1.

Strapping may be recyclable. Contact your supplier for further information.

1. Scope

1.1 This guide covers information on flat strapping materials (steel or nonmetallic) for the prospective user wanting initial guidance in selecting a strapping material and applied configuration for use in packaging (closing, reinforcing, baling, unitizing, or palletizing) and loading (load unitization and securement to transport vehicle) applications. The use applies to handling, storage, and distribution systems.

1.2 Carrier associations have established certain packaging and loading requirements that in some cases specify a type of

strap, the minimum size or strength, or both, and type of joint or seal, or both, that must be used for certain types of shipments or under certain conditions. Users should consult with their carriers initially to determine if there are applicable, published requirements. Individual carriers may establish their own requirements.

1.3 *Limitations*— This guide is not intended to give specific information as to how strapping must be used in any particular packaging or loading situation. Rather it is intended to be informational in nature and is offered as a starting point for testing. The need for thorough user testing is to be emphasized as is a review of pertinent regulations that can influence the selection of sizes, types, and possibly, application methods.

¹ This guide is under the jurisdiction of ASTM Committee D-10 on Packaging and is the direct responsibility of Subcommittee D10.25 on Palletizing and Unitizing of Loads.

Current edition approved April 10, 2000. Published June 2000. Originally published as D 4675 – 87. Last previous edition D 4675 – 93.

1.4 The sections in this guide appear in the following order:

	Section
Scope	1
Referenced Documents	2
Terminology	3
Significance and Use	4
Safety Hazards	5
General Considerations:	
Properties of Strap Types	6
General Uses	7
Strap Tension	8
Packaging Design:	
Distribution	9
Package Configuration	10
Strap Selection	11
Joining Methods and Properties	
Joint Methods and Properties (except loop joint)	12
Loop Joint and Seal Properties	13
Coatings:	
Strap Coatings and Purposes	14
Application:	
Equipment for Strap Application	15
Strap Application	16
Testing and Evaluation:	
Testing and Developing Final Package Design	17
Evaluation of Strap Failure	18
Keywords	19
Supplementary Guideline	S1

1.5 The values stated in inch-pound units are to be regarded as the standard. The SI units given in parentheses are for information only.

iTeh Standards
(<https://standards.iteh.ai>)
Document Preview

[ASTM D4675-00](#)

<https://standards.iteh.ai/catalog/standards/sist/252b8fe1-4cc5-4fcf-a301-5d8a05e5e36e/astm-d4675-00>

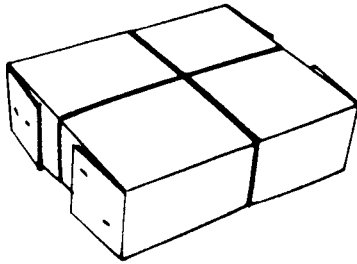

(a) Fiberboard Box Closure

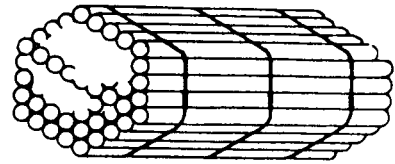

(b) Bundles of Tubing

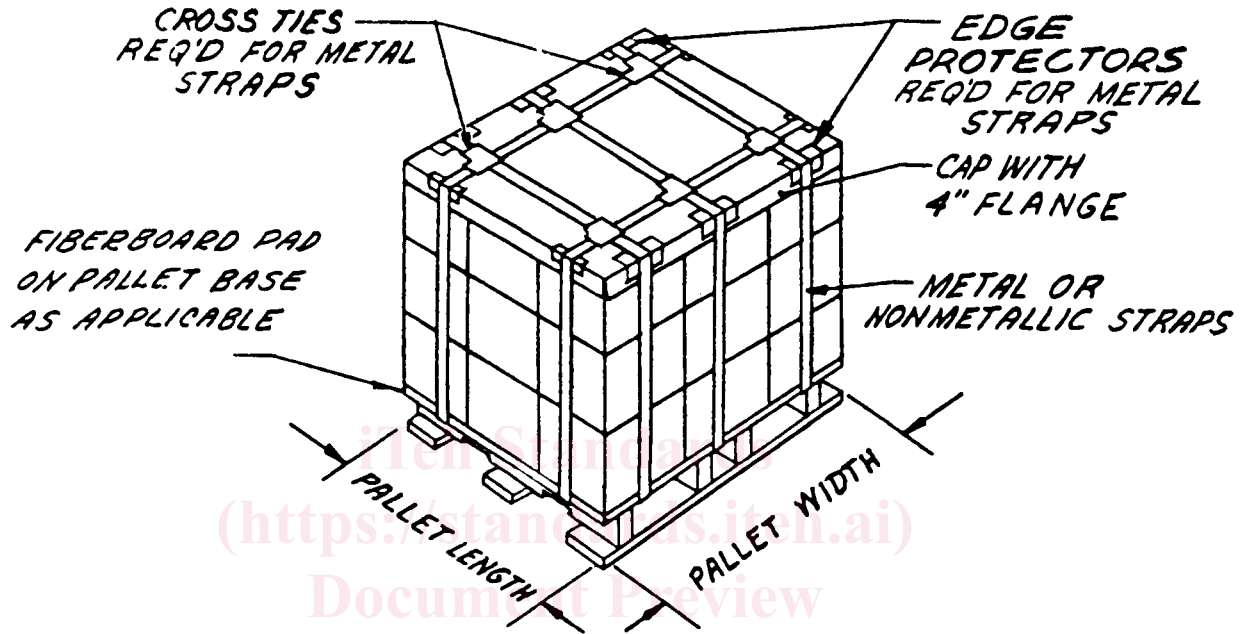

LOAD WITH CAP AND STRAPPING.

(c) Pallet

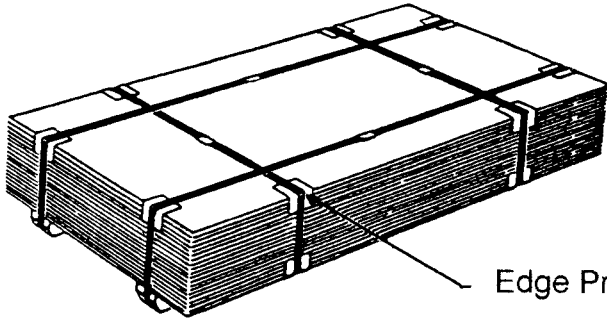

(d) Unitized Sheets

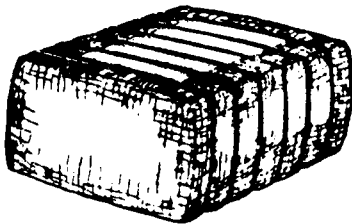

(e) Bales of Textile Fiber

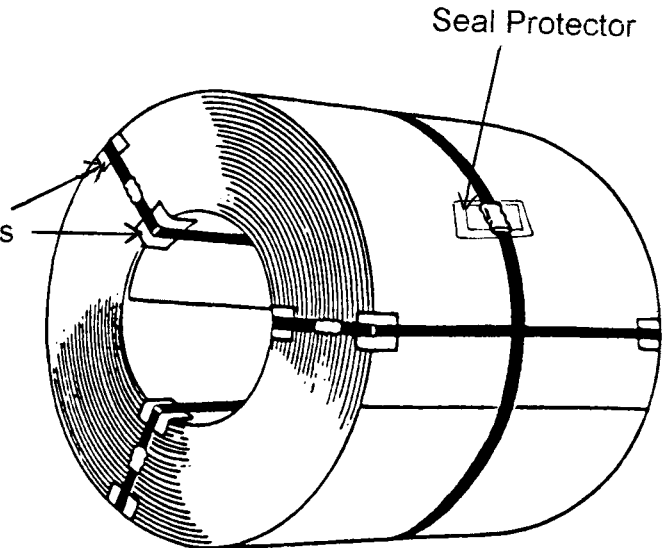

(f) Coils

FIG. 1 Applications for Steel and Nonmetallic Strapping

1.6 *This standard does not purport to address all of the safety concerns, if any, associated with its use. It is the responsibility of the user of this standard to establish appropriate safety and health practices and determine the applicability of regulatory limitations prior to use.* Specific safety hazard statements are given in Section 5 and Note 1 and Note 2.

2. Referenced Documents

2.1 ASTM Standards:

D 996 Terminology of Packaging and Distribution Environments²

D 3950 Specification for Strapping, Nonmetallic (and Joining Methods)²

D 3953 Specification for Strapping, Flat Steel and Seals²

D 4169 Practice for Performance Testing of Shipping Containers and Systems²

2.2 Other Standards:

Uniform Freight Classification Call, Rule 41, Section 9³

National Motor Freight Classification 100-L, Item 222, Section 7⁴

STA, International Safe Transit Association, Pre-shipment Test Procedures⁵

Association of American Railroads—Railing⁶

3. Terminology

3.1 *Definitions*—For general definitions of packaging and distribution environments, see Terminology D 996.

3.2 *Definitions of Terms Specific to This Standard:* The following refer to the characteristics and properties of strapping materials. These can be objectively measured to some extent and are used to rank the relative effectiveness of different strapping materials in different applications. The definitions given here are for the purposes of this guide only and do not necessarily reflect general usage or ASTM standard definitions. Some properties are common to both steel and nonmetallic strapping. Other properties are peculiar to nonmetallic only, or to steel only.

3.2.1 *break strength, n*—the longitudinal tensile force that must be applied to cause a strap to rupture. (See Specifications D 3950 and D 3953.)

3.2.2 *corner break strength, n*—the reduced break strength due to the strap being bent around an edge. (See Specification D 3953.)

3.2.3 *dead stretch (creep), n*—permanent deformation, resulting from the application of tension over time.

3.2.4 *ductility in bending (resistance to “work hardening”), n*—ductility is the opposite of “brittleness”. This quality is related to corner break strength and closely allied with strength

and elongation in determining impact resistance. It is also important in tensioning applications requiring the strap to be bent double, and in loop joint applications. (Specification D 3953 contains test procedures and specifications.)

3.2.5 *elongation at break, n*—the increase in strapping length due to tensile load at the time of break. (See Specifications D 3950 and D 3953.)

3.2.6 *energy to break, n*—the maximum force required to break a strap as measured by the area under the stress-strain curve.

3.2.7 *environmental resistant properties* (see Table 1):

3.2.8 *atmospheric contamination, n*—the presence of chemicals in the atmosphere which degrades strap properties. (See Section 14.)

3.2.9 *mechanism, n*—includes application, tool, tooling, tensioner, sealer, and power strap equipment.

3.2.10 *moisture sensitivity, n*—the degradation of properties caused by presence of moisture or moisture vapor.

3.2.11 *temperature sensitivity, n*—the deterioration of properties caused by high or low temperatures.

3.2.12 *ultraviolet light sensitivity, n*—the degradation of strapping caused by ultraviolet rays from sunlight or electric lamps.

3.2.13 *joint efficiencies, n*—joint strength divided by the minimum acceptable breaking strength of the strap, expressed as a percentage. (See Specifications D 3950 and D 3953 for minimum acceptable percentage values.)

3.2.14 *joint strength, n*—the highest longitudinal tensile force that must be applied to cause a strap joint to fail.

3.2.15 *notch sensitivity, n*—a measure of the ability of a strapping material to resist “nick or cut” propagation.

3.2.16 *settling tolerance, n*—the ability of a strap to remain taut when used to confine a settling unit load.

3.2.17 *shear plane, n*—a shear plane is the surface area between two contiguous items that will allow the items to slide relative to each other when a force is applied.

3.2.18 *tension transmission, n*—the ability of strapping to transmit tension around an edge.

TABLE 1 Strapping Preference as a Function of Handling Severity of Elements

Type	Specification D 3953		Specification D3950				
	Regular-Duty Steel	Heavy-Duty Steel	Bonded Rayon Cord	Bonded or Woven Polyester Cord	Polyolefin Plastic (Polypropylene)	Nylon Plastic	Polyester Plastic
Ultraviolet ^A	x	x	...	x
Moisture	x	x	...	x	x	...	x
Elevated temperatures	x	x	x	x	...	x	x
Low temperatures	x	x	x	x	...	x	x
Exposure to corrosives	x	x	x	x	x
Concern for damage to unit surface	x	x	x	x	x

^A UV inhibitors are available for polypropylene, nylon, and polyester plastics.

² Annual Book of ASTM Standards, Vol 15.09.

³ National Railroad Freight Classification, available from Uniform Classification Committee, 222 South Riverside Plaze, Chicago, IL 60606.

⁴ National Motor Freight Classification, 2200 Mill Rd., Alexandria, VA 22314.

⁵ International Safe Transit Association, 1400 Abbott Road, Suite 310, East Lansing, MI 48823-1900.

⁶ Association of American Railroads—Railing, Association of American Railroads—Railing Highwoods Center, 7001 Weston Parkway, Suite 200, Cary, NC 27513.

3.2.19 *yield point, n*—when a strap is subjected to load beyond its elastic limit, the point at which a strap reaches permanent deformation or continues to deform without an increase in load.

4. Significance and Use

4.1 This guide assists the user in selecting a strapping material and configuration for initial handling, transit, and storage tests. It describes general unit (load) types, strapping properties, unit-strapping interaction, weight considerations, unit shear planes, component frictional characteristics, and unit geometry. See Appendixes X1 and X2 for Department of Defense cross reference of documents.

5. Safety Hazards

5.1 *Cutting Strap*— All working strapping is under tension when in use. Sudden release of this tension will produce a hazard when the loose ends snap free after being intentionally or accidentally cut, frayed, or otherwise released. Contents under restraint or the strap itself, or both, may spring toward operator when strap tension is suddenly released. *Cutting tensioned strap is hazardous.* Use caution and follow approved safety procedures.

5.1.1 When cutting a tensioned strap, always stand to one side of the strap being cut, pressing the strap against the package above the cutter.

5.1.2 Excessive tensioning may cause strap breakage. Always position yourself to one side of strap being tensioned. Never stand directly over or in front of a strap being tensioned.

5.1.3 Never operate the tool in such a manner that a hand could slip resulting in a loss of balance.

5.2 *Reuse*—Since mechanical properties of strapping may be altered by tensioning or during physical distribution cycles, the reuse of strapping is discouraged.

5.3 *Altering or Improper Use of Tensioners*—Do not extend length of handle on manual tensioner, nor exceed the manufacturer's recommended maximum air pressure on pneumatic tensioners to gain increased strap tension. To do so could result in sudden strap failure or breakage of tensioner with potential severe injury to the operator.

5.4 *Improper Use*— Strapping should be used only as intended, that is, strapping should not be punched by nails,

staples or other sharp objects. This may cause premature strap failure. Also, attempting to nail through steel strapping may present a hazard especially when power nailing or stapling. Type 2 steel strapping has pre-punched holes intended for nail-on applications.

5.5 Never use strapping as a means of pulling or lifting of any packages, unless specified by strapping supplier (see Table 2).

GENERAL CONSIDERATIONS

6. General Properties of Strap Types (See Table 3 and Table 4)

6.1 *Steel Strapping*— This product is described in Specification D 3953 and is generally classified into regular-duty and heavy-duty strapping. Of all the types of strapping, steel strapping has the highest tensile strength (break strength for a given cross-sectional area) and resistance to tension decay or creep. It is better suited to expanding or rigid units than it is to units that settle because it has a low settling tolerance. Heavy-duty steel strapping is suggested for applications where break strength or elongation, or both, are overriding considerations. It is also suggested for high-temperature applications.

6.2 Nonmetallic Strapping:

6.2.1 *Corded Strapping (Type I and Ia)*—These products are described in Specification D 3950. Corded strapping consists of two basic types, rayon and polyester.

6.2.1.1 Of all types of strapping, polyester corded has high energy to break for a given cross section. Heavy-duty and extra-heavy-duty polyester corded strapping are suggested for applications where break strength and energy to break are overriding considerations. Polyester corded strapping is more resistant to weathering and moisture than rayon corded strapping. Use wire buckles where maximum joint efficiency is required. Corded strapping may also be joined using plastic buckles, seals, or hand-tied knots.

6.2.2 *Polyolefin (Polypropylene) (Type II)*—Polyolefin strapping is described in Specification D 3950. Polyolefin strapping is used to describe strapping made from two closely related materials, polypropylene homopolymer and polypropylene copolymer. While these materials have excellent resistance to moisture they are the least heat-resistant of all the

TABLE 2 Overall Comparison of Strapping Properties^A

Properties	Specification D 3953		Specification D 3950			
	Type 1 ^B Steel	Type 1 ^A Bonded or Woven Polyester Cord	Type 1 Bonded Rayon Cord	Type 2 Polyolefin Plastic (Polypropylene)	Type 3 Nylon Plastic	Type 4 Polyester Plastic
Break strength	1	2	4	6	5	3
Elongation	6	5	4	1	2	3
Elastic range	2	1	3	5	6	4
Resistance to tension decay	1	2	3	6	5	4
Environmental resistance	4	1	6	5	3	2
Notch sensitivity	5	1	2	6	4	3
Resistance to dead stretch (creep)	1	2	3	6	5	4
Energy to break	6	1	3	5	4	2
Corner break strength	3	1	4	6	5	2
Settling tolerance	6	3	5	2	1	4

^A The properties are ranked such that (1) is the highest and (6) is lowest. Comparison of the properties is based, where applicable, on equal cross-sectional areas.
^B Basically, two types of steel strapping are available, regular and heavy duty. Heavy duty has greater elongation and ductility properties and is required for severe shock applications, such as load securement in rail cars, and log bundling.

TABLE 3 Strapping Preference as a Function of Unit Type

Strapping Type	Unit Type				
	Severely ^A Settling	Moderately ^B Settling	Rigid	Moderately Expanding	Severely Expanding
<i>Specification D 3953:</i> Steel Strapping Regular or Heavy Duty	C	C	D
<i>Specification D 3950:</i> Type I Cord Strapping (Rayon) (Regular Duty)	E	C	C	C	...
Type IA Cord Strapping (Polyester)	E	C	C	C	C
(Polypropylene) Polyolefin Plastic Strapping	E	C	C
Nylon Plastic Strapping	E	C	C
Polyester Plastic Strapping	E	C	C	C	C

^A *Severe*—A perimeter change of 2 % or more.

^B *Moderate*—A perimeter change of less than 2 %.

^C Generally recommended.

^D Best choice, other factor being equal.

^E With buckles, can be retensioned.

common strapping materials and also have the greatest tension decay or creep of any of the common materials. Of the nonmetallic strapping materials, they are the most easily heat sealed or fusion joined. They tend to be more suitable for light to medium duty applications.

6.2.3 *Nylon (Type III)*—Nylon strapping is described in Specification D 3950. Nylon strapping has the highest elongation recovery of any strapping material, that, combined with a relatively low dead stretch, gives it the highest settling tolerance. With loads where severe settling is the major consideration, nylon would be the preferred strapping material. In terms of break strength, it is comparable to that of the polyolefins and polyester strapping material. It has the best cold-temperature performance of the nonmetallic group, but is most susceptible to moisture degradation.

6.2.4 *Polyester (Type IV)*—Polyester strapping is described in Specification D 3950. Polyester has the lowest elongation in the working range and the least tension decay or “creep” of all the nonmetallic strappings. This makes it somewhat more suitable for rigid and expanding loads. Polyester strapping generally exhibits good resistance to the effects of temperature and moisture.

7. General Uses

7.1 Strap may be used to secure a handling base (skids, platforms, pallets, runners, spacers, etc.) to a unit to expedite handling, for example, 2 by 4-in. (5.08 by 10.16 mm) runners strapped to a concrete or steel slab to allow a fork lift or crane and cable handling or to secure other packaging materials (battans, stiffeners, wrappings, etc.), or both, in position. (See Fig. 1.)

7.2 Strap may be used for load securement to or within the transport vehicle. It is then applied under tension to restrain or control the movement of lading, and thus must accommodate in-transit shocks or irregular movements. Carrier regulations provide guidelines or minimum requirements, or both.

7.3 Strap also may provide security against accidental loss or theft of the contents or indicate a loss or theft.

7.4 Strap functions best when all resultant forces act directly parallel, in line, with the direction of the strap.

8. Strap Tension

8.1 Strap primarily functions under tension. This tension basically:

8.1.1 Imposes circumferential (peripheral) compressive forces to resist a change in configuration, for example, tubing secured in hexagonal or round unit, scrap paper secured in bales, etc., or the following, or both. (See Fig. 1.)

8.1.2 Increases the frictional forces between the adjacent surfaces within the unit, for example, between cartons on a pallet and between the cartons and the pallet.

PACKAGING DESIGN

9. Distribution

9.1 Identify receivers (consignees) and their locations relative to shipping point(s) (consignors).

9.2 Determine receiver’s needs and requirements. This will provide information on handling equipment and practices, storage practices and conditions, and possible specific requirements of individual users.

9.3 Determine applicable transportation modes: air, water, rail, or truck. This will further define the shipping conditions and applicable rules and regulations. See 2.2.

9.4 Contact potential carriers within each mode and determine if there are any general or specific rules and regulations.

9.5 The carriers can provide information as to the type of equipment that will best suit specific needs.

10. Package Configuration

10.1 Generally, the “ideal” package configuration is one that:

10.1.1 Can be safely handled in the distribution system,

10.1.2 Protects the security of the contents,

10.1.3 Meets the receiver’s requirements,

10.1.4 Secures easily on or to transportation equipment,

10.1.5 Maximizes use of space in warehouses and transportation equipment, and

10.1.6 Can be easily assembled and disassembled.

10.2 The configuration used should have its center of gravity as low as practical for maximum stability during handling, transit, and storage.

11. Strap Selection

11.1 Strap size, type, placement, and number required are all a function of the work to be done, that is determined by a number of factors. These factors include: number and direction of shear planes, friction of contact surfaces between all shear planes, size, shape and weight of unit load, expected severity of handling, nature of transport equipment, and exposure to environmental conditions, particularly if prolonged outdoor exposure is anticipated. (See Table 1.)

11.2 Contents have a tendency to react in one of three ways. They can expand, remain rigid, or settle. Contents may appear to be one type and later with different conditions exhibit the characteristic of another type. Strap selection must accommodate anticipated content reaction.

11.2.1 *Expanding Contents:*

11.2.1.1 Natural and synthetic fibers, or scrap paper that are compressed prior to strap placement,