



Designation: E 1050 – 07

Standard Test Method for Impedance and Absorption of Acoustical Materials Using A Tube, Two Microphones and A Digital Frequency Analysis System¹

This standard is issued under the fixed designation E 1050; the number immediately following the designation indicates the year of original adoption or, in the case of revision, the year of last revision. A number in parentheses indicates the year of last reapproval. A superscript epsilon (ϵ) indicates an editorial change since the last revision or reapproval.

1. Scope

1.1 This test method covers the use of an impedance tube, two microphone locations, and a digital frequency analysis system for the determination of normal incidence sound absorption coefficients and normal specific acoustic impedance ratios of materials.

1.2 *Laboratory Accreditation*—A procedure for accrediting a laboratory for performing this test method is given in **Annex A1**.

1.3 *This standard does not purport to address the safety concerns, if any, associated with its use. It is the responsibility of the user of this standard to consult and establish appropriate safety and health practices and determine the applicability of regulatory limitations prior to use.*

2. Referenced Documents

2.1 ASTM Standards:

C 384 Test Method for Impedance and Absorption of Acoustical Materials by Impedance Tube Method

C 634 Terminology Relating to Building and Environmental Acoustics

E 548 Guide for General Criteria Used for Evaluating Laboratory Competence²

2.2 ISO Standards:

ISO 10534-1 Acoustics—Determination of Sound Absorption Coefficient and Impedance or Admittance—Part 1: Impedance Tube Method³

ISO 10534-2 Acoustics—Determination of Sound Absorption Coefficient and Impedance in Impedance Tubes—Part 2: Transfer-Function Method³

¹ This test method is under the jurisdiction of ASTM Committee E33 on Building and Environmental Acoustics and is the direct responsibility of Subcommittee E33.01 on Sound Absorption.

Current edition approved Dec. 1, 2007. Published January 2008. Originally approved in 1985. Last previous edition approved in 2006 as E 1050 - 98 (2006).

² Withdrawn.

³ Available from American National Standards Institute (ANSI), 25 W. 43rd St., 4th Floor, New York, NY 10036, <http://www.ansi.org>.

3. Terminology

3.1 *Definitions*—The acoustical terminology used in this test method is intended to be consistent with the definitions in Terminology **C 634**.

NOTE 1—Historical literature regarding the measurement of normal incidence absorption coefficients referred to “transfer function” measurements; however, the term arises from Laplace transform theory and is not strictly rigorous when the initial conditions have a non-zero value. The term “frequency response function” arises from more general Fourier transform theory (**1**).⁴ This test method shall retain the use of the former term although not technically correct. Users should be aware that modern FFT analyzers may employ the latter terminology.

3.2 *Symbols*: The following symbols are used in Section 8 (Procedure):

3.2.1 b_{pc} —normal specific acoustics susceptance ratio.

3.2.2 c —speed of sound, m/s.

3.2.3 g_{pc} —normal specific acoustic conductance ratio.

3.2.4 G_{11} , G_{22} —auto power spectra of the acoustic pressure signal at microphone locations 1 and 2, respectively.

3.2.5 G_{12} —cross power spectrum of the acoustic pressure signals at microphones locations 1 and 2.

3.2.6 H —transfer function of the two microphone signals corrected for microphone response mismatch.

3.2.7 \bar{H} —measured transfer function of the two microphone signals.

3.2.8 H^I , H^{II} —calibration transfer functions for the microphones in the standard and switched configurations, respectively.

3.2.9 \bar{H}_c —complex microphone calibration factor.

3.2.10 j —equals $\sqrt{-1}$.

3.2.11 k —equal $2\pi f/c$; wave number, m^{-1} .

3.2.11.1 *Discussion*—In general the wave number is complex where $k = k' - jk''$. k' is the real component, $2\pi f/c$ and k'' is the imaginary component of the wave number, also referred to as the attenuation constant, Nepers- m^{-1} .

⁴ The boldface numbers in parentheses refer to the list of references at the end of this test method.

3.2.12 l —distance from the test sample to the centre of the nearest microphone, m.

3.2.13 $r/\rho c$ —normal specific acoustic resistance ratio.

3.2.14 R —complex acoustic reflection coefficient.

3.2.15 s —centre-to-center spacing between microphones, m.

3.2.16 $x/\rho c$ —normal specific acoustic reactance ratio.

3.2.17 $Y/\rho c$ —normal specific acoustic admittance ratio.

3.2.18 $z/\rho c$ —normal specific acoustic impedance ratio.

3.2.19 a —normal incidence sound absorption coefficient.

3.2.20 ϕ —phase of the complex transfer function, radians.

3.2.21 ϕ_R —phase of the complex acoustic reflection coefficient, radians.

3.2.22 ρ —density of air, kg/m³.

3.3 *Subscripts, Superscripts, and Other Notation*—The following symbols, which employ the variable X for illustrative purposes, are used in Section 8:

3.3.1 X_c —calibration.

3.3.2 X_i —imaginary part of a complex quantity.

3.3.3 X_r —real part of a complex quantity.

3.3.4 X^I, X^{II} —calibration quantities measured with microphones placed in the standard and switched configurations, respectively.

3.3.5 \bar{X} —measured quantity prior to correction for amplitude and phase mismatch.

3.3.6 $|X|$ —magnitude of a complex quantity.

4. Summary of Test Method

4.1 This test method is similar to Test Method C 384 in that it also uses an impedance tube with a sound source connected to one end and the test sample mounted at the other end. The measurement techniques for the two methods are fundamentally different, however. In this test method, plane waves are generated in the tube using a broad band signal from a noise source rather than a discrete sinusoid from an oscillator. The decomposition of the stationary sound wave pattern into forward- and backward-traveling components is achieved by measuring sound pressures simultaneously at two spaced locations in the tube's side wall. Calculations of the normal-incidence absorption coefficients for the acoustical material are performed by processing an array of complex data from the measured transfer function.

4.2 The quantities are determined as functions of frequency with a resolution determined by the sampling rate of a digital frequency analysis system. The usable frequency range depends on the diameter of the tube and the spacing between the microphone positions. An extended frequency range may be obtained by using tubes with various diameters and microphone spacings.

4.3 This test method is intended to provide a much faster measurement technique than that of Test Method C 384.

5. Significance and Use

5.1 This test method can be applied to measure sound absorption coefficients of absorptive materials at normal incidence, that is, 0°. It also can be used to determine specific impedance and admittance ratios. The properties measured with this test method are useful in basic research and product development of sound absorptive materials.

5.2 Normal incidence sound absorption coefficients can be quite useful in certain situations where the material is placed within a small acoustical cavity close to a sound source, for example a closely-fitted machine enclosure.

5.3 This test method allows one to compare relative values of sound absorption when it is impractical to procure large samples for accurate random-incidence measurements in a reverberation room. Estimates of the random incidence absorption coefficients can be obtained from normal impedance data for locally-reacting materials (2).

NOTE 2—The classification, “locally-reacting” includes fibrous materials having high internal losses. Formulas have been developed for converting sound absorption properties from normal incidence to random incidence, for both locally-reacting and bulk-reacting materials (3).

5.4 Measurements described in this test method can be made with high precision, but these measurements may be misleading. Uncertainties of greater magnitude than those from the measurements may occur from other sources. Care should be exercised to sample nonuniform materials adequately (see 11.1).

6. Apparatus

6.1 The apparatus is a hollow cylinder, or tube, with a test sample holder at one end and a sound source at the other. Microphone ports are mounted at two or more locations along the wall of the tube. A two channel digital frequency analysis system is used for data acquisition and processing.

6.2 Tube:

6.2.1 *Construction*—The interior section of the tube may be circular or rectangular with a constant dimension from end-to-end. The tube shall be straight and its inside surface shall be smooth, nonporous, and free of dust to maintain low sound attenuation. The tube construction shall be massive so sound transmission through the tube wall is negligible.

NOTE 3—The tube can be constructed from materials including metal, plastic, cement, or wood. It may be necessary to seal the interior walls with a smooth coating in order to maintain low sound attenuation for plane waves.

6.2.2 *Working Frequency Range*—The working frequency range is:

$$f_l < f < f_u \quad (1)$$

where:

f = operating frequency, hertz,

f_l = lower working frequency of the tube, hertz, and

f_u = upper working frequency of the tube, hertz.

6.2.2.1 The lower frequency limit depends on the spacing of the microphones and the accuracy of the analysis system. It is recommended that the microphone spacing exceed one percent of the wavelength corresponding to the lower frequency of interest.

6.2.2.2 The upper frequency limit, f_u , and the corresponding wavelength, λ_u , depends on the diameter of the tube and upon the speed of sound.

6.2.3 *Diameter*—In order to maintain plane wave propagation, the upper frequency limit (4) is defined as follows:

$$f_u < K c / d \quad \text{or} \quad d < K c / f_u \quad (2)$$

where:

- f_u = upper frequency limit, hertz,
- c = speed of sound in the tube, m/s,
- d = diameter of the tube, m, and
- $K = 0.586$.

6.2.3.1 For rectangular tubes, d is defined as the largest section dimension the tube and K is defined as 0.500. Extreme aspect ratios greater than 2:1 or less than 1:2 should be avoided. A square cross-section is recommended.

6.2.3.2 It is best to conduct the plane wave measurements well within these frequency limits in order to avoid cross-modes that occur at higher frequencies when the acoustical wave length approaches the sectional dimension of the tube.

6.2.4 *Length*—The tube should be sufficiently long as plane waves are fully developed before reaching the microphones and test specimen. A minimum of three tube diameters must be allowed between sound source and the nearest microphone. The sound source may generate nonplane waves along with desired plane waves. The nonplane waves usually will subside at a distance equivalent to three tube diameters from the source. If measurements are conducted over a wide frequency range, it may be desirable to use a tube which provides multiple microphone spacings or to employ separate tubes. The overall tube length also must be chosen to satisfy the requirements of 6.4.3, 6.5.3, and 6.5.4.

6.2.5 *Tube Venting*—Some tube designs are such that, during during installation or removal of the test specimen, large temporary pressure variation may be generated. This may induce microphone diaphragm deflection. The potential for damage to a microphone diaphragm due to excessive deflection may be reduced including a pressure relief opening in the tube. This may be accomplished by drilling a small hole, 1 to 2 mm through the wall of the tube. It is recommended to locate the tube vent near the sound source, away from microphone locations, and to seal the vent during acoustic measurements.

6.3 *Test Specimen Holder:*

6.3.1 *General Features*—The specimen holder may either be integrated with the impedance tube or may be a separate, detachable extension of the tube. Provision must be made for mounting the specimen with its face in a known position along the tube axis and for placing a heavy backing plate behind the specimen. For some measurements it may be desirable to maintain an airspace of known dimensions between the speci-

men and the backing plate. One such arrangement may be to simulate a suspended ceiling tile.

6.3.2 *Detachable Holder*—As a detachable unit, the holder must make an airtight fit with the end of the tube opposite the sound source. The holder must conform with the interior shape and dimensions of the main part of the impedance tube. The connecting joint must be finished carefully and the use of a sealant, such as petroleum jelly or silicone grease, is recommended for sealing.

6.3.3 *Integral Holder*—If the sample holder is in an integral part of the impedance tube, it is recommended to make the installation section of the tube accessible for mounting of the specimen by a removable cover. The mating surfaces must be finished carefully, and the use of a sealant is recommended for sealing.

6.3.4 *Circular Holder*—For circular tubes, it is recommended to make the specimen accessible from both the front and back end of the sample holder. It is possible then to check the position and flatness of the front surface and back position. Holders may be constructed from a rigid, clear material, such as acrylic, to facilitate inspection.

6.3.5 *Rectangular Holder*—With rectangular tubes, it is recommended to install the specimen from the side, making it possible to check the fitting and the position of the specimen in the tube and to check the position and flatness of the front surface.

6.3.6 *Backing Plate*—The backing plate of the sample holder shall be rigid and shall be fixed tightly to the tube since it serves to provide a sound-reflective termination in many measurements. A metal plate having a minimum thickness of 20 mm is recommended.

6.4 *Sound Source:*

6.4.1 *Kind and Placement*—The sound sources should have a uniform power response over the frequency range of interest. It may either be coaxial with the main tube or joined to the main tube by means of a transition having a straight, tapered, or exponential section (see Fig. 1).

6.4.2 *Isolation*—The sound source and transition shall be sealed and isolated from the tube to minimize structure-borne sound excitation of the impedance tube. If a direct radiator

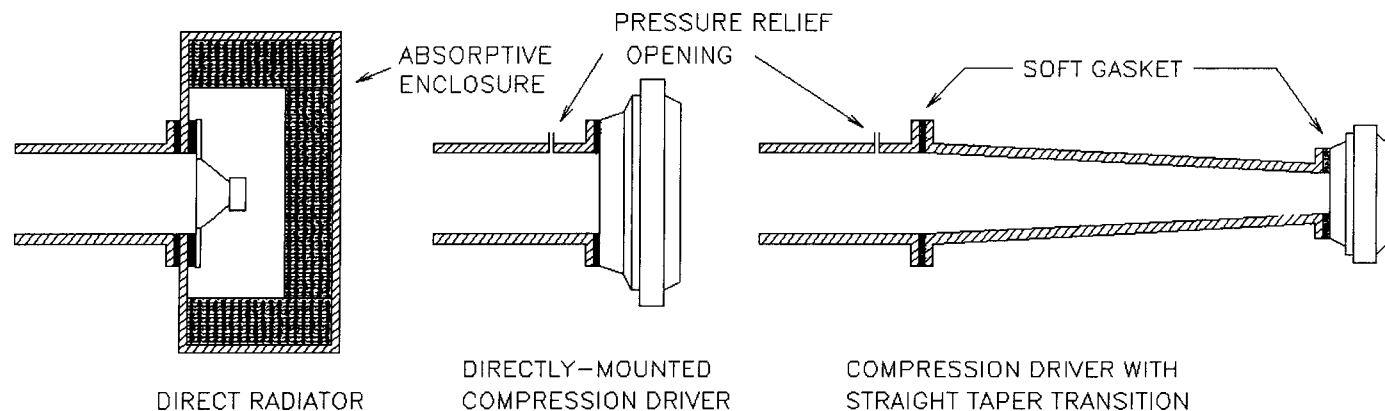

FIG. 1 Sound Source Configurations

loudspeaker is utilized, it shall be contained in a sound-isolating enclosure in order to avoid airborne flanking transmission to the microphones (see Fig. 1).

6.4.3 *Termination*—Resonances of the air column in the impedance tube may arise if the mechanical impedance of the loudspeaker membrane or diaphragm is high. In this case, it is recommended to apply a porous absorber coating or lining inside either the impedance tube near the loudspeaker or inside the sound transition. Alternatively, the locations described above may be filled lightly with a low density absorbing material.

6.4.4 *Equalization*—When an absorptive medium is placed near the sound source as described in 6.4.3, significant sound energy will be lost at higher frequencies. An electronic equalizer may be required to shape and sound spectra measured at the microphone positions so that they are relatively flat. This will minimize the loss of signal-to-noise capability at high frequencies.

6.5 Microphones:

6.5.1 *Type, Diameter*—Two nominally identical microphones shall be mounted according to 6.5.4. The microphone diameter must be small in comparison with the spacing between microphone ports and also to minimize spatial averaging at higher frequencies across the diaphragm face. It is recommended that the microphone diameter be less than 20 % of the wavelength for the highest frequency of interest. Table 1 provides maximum recommended frequency limits for several typical microphone sizes used at room temperature. Where greater microphone sensitivity is required, larger diameters may be selected for use with large tubes working at low frequencies.

6.5.2 *Microphone Venting*—Microphones are designed with a vent to allow for static pressure equalization on either side of the diaphragm. In general, venting may be accomplished either to the inside or to the outside of the tube. Two alternate venting methods are available: back-vented (preferred) (5) and side-vented. A microphone pair of either design may be used. Microphones must be sealed carefully when installed in the impedance tube to avoid leaks, which may interfere with proper operation of the microphone vent, thus causing significant changes to the low frequency response. Blockage of a vent of an individual microphone will alter its phase response, resulting in large errors in the measurements.

6.5.2.1 *Back-Vented Microphones*—Back-vented microphones are vented out through the back of the preamplifier barrel to the outside of the tube. Very low frequency accuracy is improved when the static pressure equalization vent is isolated from the sound field within the impedance tube (6). Back-vented microphones are designed so that the venting path proceeds from the rear of the microphone cartridge

through the preamplifier. Sealing may be accomplished either against the rear of the microphone cartridge barrel or against the protection grid. If the seal is established against the latter, the threads of the protection grid should be sealed with silicone grease to prevent leakage between the tube interior and the back vent, (see Fig. 2).

6.5.2.2 *Side-Vented Microphones*—Side-venting path proceeds from the vent opening, which is located between the protection grid threads and the diaphragm, to the front of the microphone, and therefore, vent to the inside of the tube. Sealing may be established either against the rear of microphone cartridge barrel or against the protection grid. If the seal is established against the latter, the threads of the protection should be sealed with silicone grease to prevent leakage (see Fig. 2).

6.5.3 *Spacing*—A large spacing between microphones enhances the accuracy of the measurements, however, the microphone spacing must be less than the shortest half wave length of interest (7).

$$s \ll c / 2f_u \quad (3)$$

where:

- s = microphone spacing, m
- c = speed of sound, m/s, and
- f_u = upper frequency limit, hertz.

It is recommended that the maximum microphone spacing, s , be 80 % of $c/2f_u$.

6.5.4 *Location*—The minimum between the sound source and the closest microphone must follow the requirements of 6.2.4. The minimum distance between the specimen and the closest microphone depends somewhat on the surface characteristics of the specimen. In order to maintain the greatest signal-to-noise ratio, the minimum spacing between the specimen and microphone can be modified as follows.

6.5.4.1 *Flat Surface*—The closest microphone can be moved to within one-half of the tube diameter, or one-half of the largest section dimension in the case of a rectangular tube.

6.5.4.2 *Nonhomogenous Surface*—The closest microphone should be at least one tube diameter, or the largest section dimension in the case of rectangular tube, to help suppress the influence of higher-order modes induced by the rough surface of the specimen.

6.5.4.3 *Asymmetrical Surface*—The closest microphone should be at least two tube diameters (two times the largest section dimension in the case of a rectangular tube) to facilitate the dissipation of higher order modes generated from a rough surface. The higher order modes will decay exponentially as they propagate along the tube. If the specimen is a wedge of the kind used in anechoic rooms, the microphones must be placed far enough from the point of the wedge to measure the transfer function in the plane wave region.

6.5.5 *Mounting*—It is desirable to mount both microphone diaphragms flush with the interior surface of the tube using port openings through the side of the tube. If the microphones are switched (Section 8), care must be taken when the microphones are removed from their port so the original mounting geometry is maintained when they are replaced. A small stop may be employed to control the depth of each microphone in

TABLE 1 Recommended Maximum Frequency Based on Microphone Diameter

Nominal Diameter (in.)	Diaphragm Diameter (mm)	Maximum Frequency (Hz)
1	22.70	3000
½	12.2	5600
¼	5.95	11 500

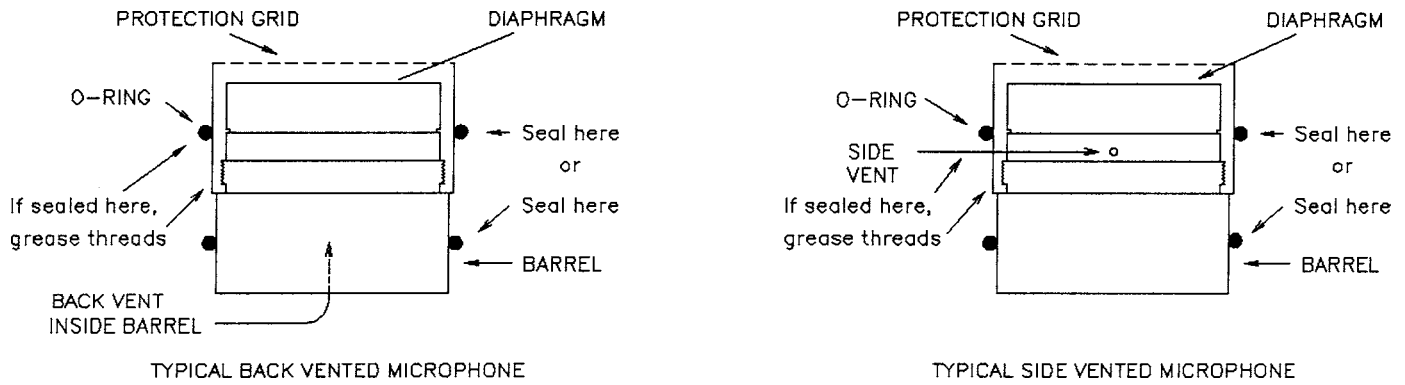

FIG. 2 Microphone Venting and Sealing

the port as shown in Fig. 3a. The lip should be kept small and identical for both microphone ports.

6.5.5.1 *Alternate Mounting*—In order to avoid the small recess caused by mounting the microphones according to 6.5.5, an alternative pinch block mounting technique may be used as shown in Fig. 3b. This method has the advantage of positioning the microphone diaphragm flush with the inside of the impedance tube (the protection grid will protrude slightly) and the pinch block provides lateral support for the microphone within the port. The pinch block must not interfere with venting provided by the microphone preamplifier.

6.5.5.2 *Microphone Acoustic Centre*—In order to help control measurement uncertainties in this test method, the lateral separation between the microphone axes needs to be precisely known. Unfortunately, the acoustical separation between microphones axes may be different slightly than their physical separation. This uncertainty becomes more pronounced as the ratio between microphone diameter and separation distance increases. Since there is no procedure available for determining the acoustical separation, it is recommended that the physical separation be controlled throughout the test series. If the microphones are switched to reduce phase mismatch errors, as discussed in Section 8, the physical separation should be maintained carefully with the aid of a jig, such as a rotating circular plate mounted in the sidewall of the tube. It is recommended the individual microphones be identified positively to monitor their relative positions during switching (see Fig. 4).

6.6 Test Signal:

6.6.1 *Signal Characteristic*—It is recommended that the test signal be random noise having a uniform spectral density across the frequency range of interest. The spectral line spacing of the test signal should be compatible with the analysis bandwidth. Alternative test signals also may be used if they have an equivalent spectral density. These alternative signals include pseudo-random noise and swept or stepped sine generation.

NOTE 4—A signal generator capable of producing a compatible test signal often is incorporated within a two-channel digital frequency analysis system. When employing alternative signals, it is recommended that each time block used in the frequency analysis be synchronized with individual repetitions of the test signal pattern.

6.6.2 *Signal-to-Noise Ratio*—The sound source shall generate sufficient signal at both microphone locations such that the measured signal in each test frequency band is at least 10 dB greater than the background noise.

6.7 Test Measuring Equipment:

6.7.1 *Measuring Apparatus*—The signal processing equipment shall consist of two identical microphones, two identical analog signal conditioners (optional) and a two-channel Fast Fourier Transform (FFT) analyzer, or equivalent. The signal from each microphone system is connected to an individual channel of the analyzer, (see Fig. 4).

6.7.2 *Computing Device*—A desktop calculator or a micro-computer, either separate from or part of the digital frequency analysis system, may be necessary in order to determine the acoustic absorption coefficient and normal specific impedance

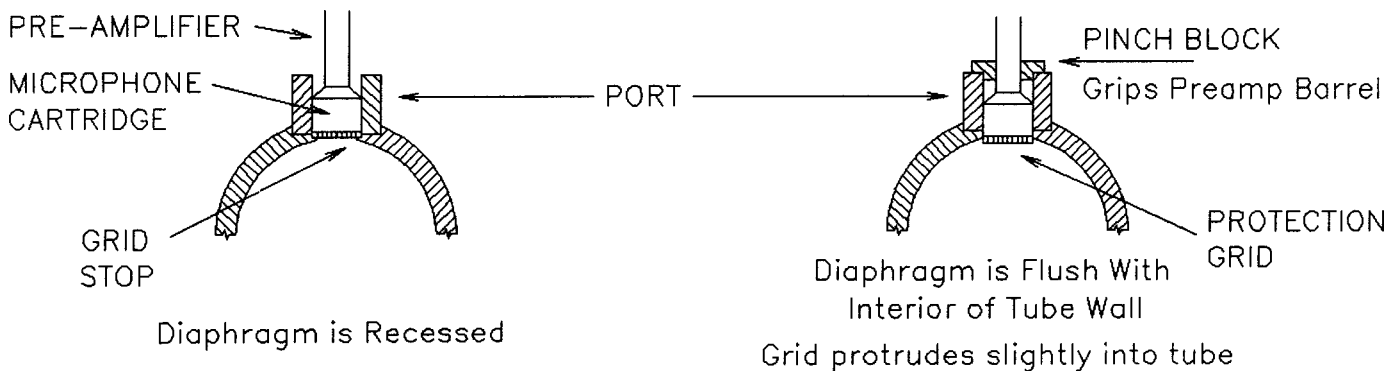

FIG. 3 Typical Microphone Mounting and Alternate Mounting

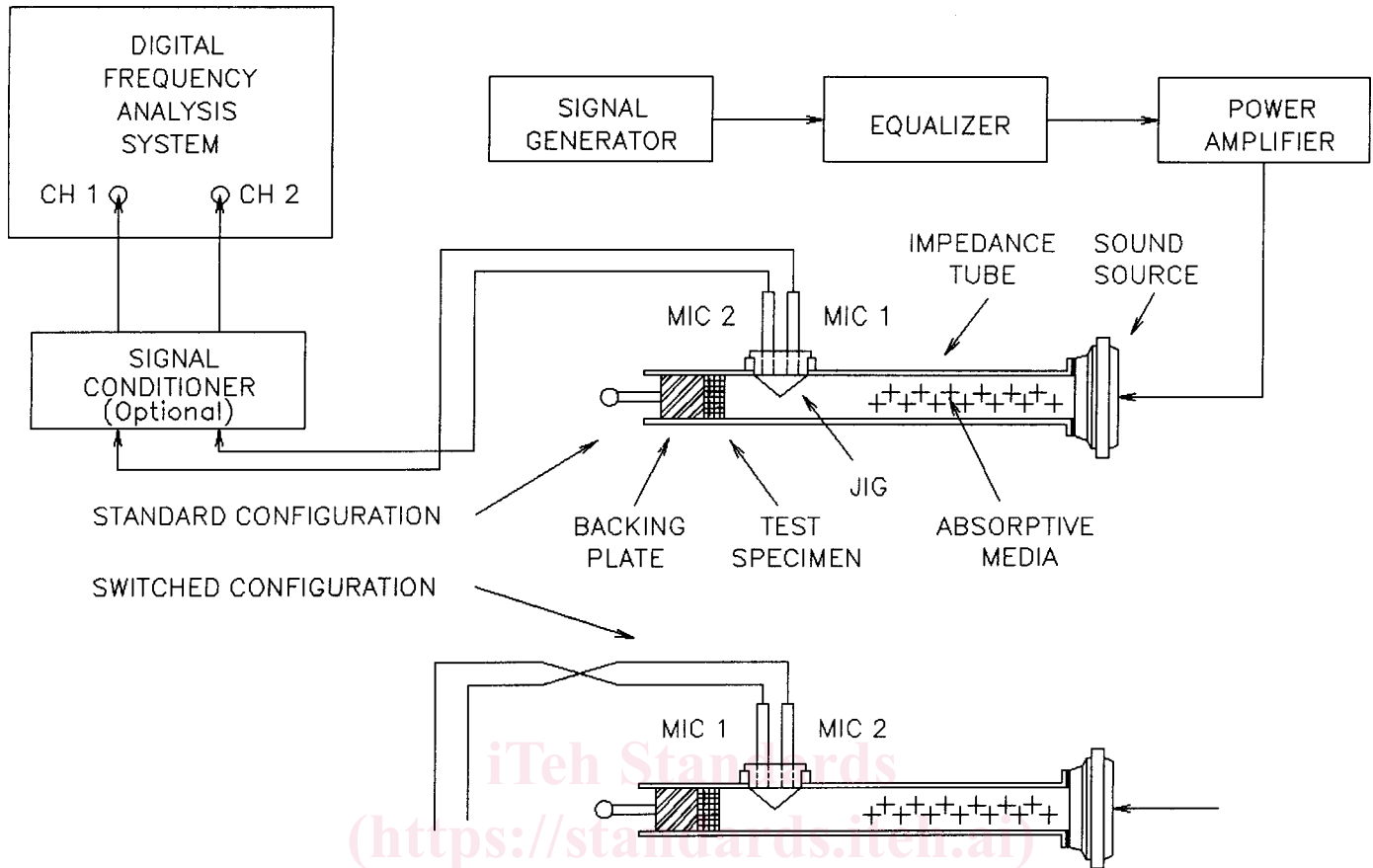

FIG. 4 Apparatus and Instrumentation

ratio from the measured transfer function data. One complete set of mathematical expressions is given in Section 8 (7). Alternative methods of performing such calculations are available (8).

6.7.3 *Temperature Sensor*—A thermometer or other ambient temperature sensing device shall be installed so the air temperature is known to within $\pm 1^\circ\text{C}$.

6.7.4 *Barometric Pressure Indicator*—A mercury barometer or other equivalent indicating device shall be located in the vicinity of the impedance tube. The atmospheric pressure shall be measured with a tolerance ± 0.5 kPa.

6.7.5 *Relative Humidity Indicator*—A device capable of determining the relative humidity of the air shall be located in the vicinity of the impedance tube. The relative humidity shall be measured to within a tolerance of 5 %.

7. Test Specimen

7.1 *Shape and Size*—Each specimen must have the same shape and area as the tube cross section. It must fit snugly into the specimen holder, not so tightly that it bulges in the center, nor so loosely that there is space between its edge and the holder. It is recommended to seal any peripheral cracks or gaps with petroleum jelly or modelling clay. It is desirable to have the specimen possess a relatively flat surface for reasons stated in 6.5.4.

7.2 *Alignment*—The front surface of test specimens shall be mounted normal to the tube axis unless the surface specifically

is designed otherwise. When the specimen has a very uneven back, which would introduce an unintended backing air space, for example, a specimen cut from a hollow concrete block, a minimal amount of putty-like material may be placed between the specimen and the backing plate. This material will seal and shim the back of the specimen so it is parallel with the backing plate. Such a procedure should be used with caution as the results may be affected by the modification to the back surface of the test specimen. An unknown airspace between the rear of a specimen and the backing plate may be the ruling factor in the result.

7.3 *Containment*—With porous materials of low bulk density, it may be helpful to define the front surface by a thin, nonvibrating wire grid with wide mesh.

7.4 *Number*—A minimum of two specimens should be cut from the sample and tested with the same mounting conditions. When the sample has a surface that is not uniform, for example, a fissured acoustical tile, additional specimens should be selected in order to include representative regions of the surface. In any case, the results should be averaged.

8. Procedure

8.1 *Apparatus and Instrumentation*—A suggested arrangement of apparatus and instrumentation is shown in Fig. 4.

8.2 *Reference Plane*—Once the test specimen has been mounted in the impedance tube according to Section 7, establish the reference plane so the distance, l , to the nearest