



Designation: ~~D97-06~~ Designation: D 97 - 07

An American National Standard



Designation: 15/95

## Standard Test Method for Pour Point of Petroleum Products<sup>1</sup>

This standard is issued under the fixed designation D 97; the number immediately following the designation indicates the year of original adoption or, in the case of revision, the year of last revision. A number in parentheses indicates the year of last reapproval. A superscript epsilon (ε) indicates an editorial change since the last revision or reapproval.

*This standard has been approved for use by agencies of the Department of Defense.*

### 1. Scope\*

1.1 This test method covers and is intended for use on any petroleum product.<sup>2</sup> A procedure suitable for black specimens, cylinder stock, and nondistillate fuel oil is described in 8.8. A procedure for testing the fluidity of a residual fuel oil at a specified temperature is described in Appendix X1. The cloud point procedure formerly part of this test method now appears as Test Method D 2500.

~~1.2~~ ~~Currently~~ 1.2 ~~Currently~~ there is no ASTM test method for automated Test Method D 97 pour point measurements.

1.3 Several ASTM test methods offering alternative procedures for determining pour points using automatic apparatus are available. None of them share the same designation number as Test Method D 97. When an automatic instrument is used, the ASTM test method designation number specific to the technique shall be reported with the results. A procedure for testing the pour point of crude oils is described in Test Method D 5853.

1.4 *This standard does not purport to address all of the safety concerns, if any, associated with its use. It is the responsibility of the user of this standard to establish appropriate safety and health practices and determine the applicability of regulatory limitations prior to use.*

### 2. Referenced Documents

#### 2.1 ASTM Standards:<sup>3</sup>

D 117 Guide for Sampling, Test Methods, and Specifications for Electrical Insulating Oils of Petroleum Origin

D 396 Specification for Fuel Oils

D 1659 Test Method for Maximum Fluidity Temperature of Residual Fuel Oil<sup>4</sup>

D 2500 Test Method for Cloud Point of Petroleum Products

D 3245 Test Method for Pumpability of Industrial Fuel Oils

D 5853 Test Method for Pour Point of Crude Oils

D 6300 Practice for Determination of Precision and Bias Data for Use in Test Methods for Petroleum Products and Lubricants

E 1 Specification for ASTM Liquid-in-Glass Thermometers

#### 2.2 Energy Institute Standards:

Specifications for IP Standard Thermometers<sup>5</sup>

### 3. Terminology

#### 3.1 Definitions:

3.1.1 *black oil, n*—lubricant containing asphaltic materials. Black oils are used in heavy-duty equipment applications, such as mining and quarrying, where extra adhesiveness is desired.

3.1.2 *cylinder stock, n*—lubricant for independently lubricated engine cylinders, such as those of steam engines and air

<sup>1</sup> This test method is under the jurisdiction of ASTM Committee D02 on Petroleum Products and Lubricants and is the direct responsibility of Subcommittee D02.07.0D on Wax-Related Viscometric Properties of Fuels and Oils.

Current edition approved Nov. Dec. 1, 2006-2007. Published November 2006-January 2008. Originally approved in 1927, replacing D 47. Last previous edition approved in 2005-2006 as ~~D97-05a~~-D 97-06.

In the IP, this test method is under the jurisdiction of the Standardization Committee. This test method was adopted as a joint ASTM-IP Standard in 1965.

<sup>2</sup> Statements defining this test and its significance when applied to electrical insulating oils of mineral origin will be found in Guide D 117.

<sup>3</sup> For referenced ASTM standards, visit the ASTM website, www.astm.org, or contact ASTM Customer Service at service@astm.org. For *Annual Book of ASTM Standards* volume information, refer to the standard's Document Summary page on the ASTM website.

<sup>4</sup> Withdrawn.

<sup>5</sup> Methods for Analysis and Testing, *IP Standards for Petroleum and its Products*, Part I, Vol 2.

\*A Summary of Changes section appears at the end of this standard.

compressors. Cylinder stock are also used for lubrication of valves and other elements in the cylinder area.

3.1.3 *pour point, n—in petroleum products*, the lowest temperature at which movement of the test specimen is observed under prescribed conditions of test.

3.1.4 *residual fuel, n*—a liquid fuel containing bottoms remaining from crude distillation or thermal cracking; sometimes referred to as heavy fuel oil.

3.1.4.1 *Discussion*—Residual fuels comprise Grades 4, 5, and 6 fuel oils, as defined in Specification D 396.

**4. Summary of Test Method**

4.1 After preliminary heating, the sample is cooled at a specified rate and examined at intervals of 3°C for flow characteristics. The lowest temperature at which movement of the specimen is observed is recorded as the pour point.

**5. Significance and Use**

5.1 The pour point of a petroleum specimen is an index of the lowest temperature of its utility for certain applications.

**6. Apparatus**

6.1 *Test Jar*, cylindrical, of clear glass, flat bottom, 33.2 to 34.8-mm outside diameter, and 115 to 125 mm in height. The inside diameter of the jar can range from 30.0 to 32.4 mm, within the constraint that the wall thickness be no greater than 1.6 mm. The jar shall have a line to indicate a sample height  $54 \pm 3$  mm above the inside bottom. See Fig. 1.

6.2 *Thermometers*, having the following ranges and conforming to the requirements prescribed in Specification E 1 for thermometers:

Thermometer	Temperature Range	ASTM	Thermometer Number	IP
High cloud and pour	-38 to +50°C	5C		1C
Low cloud and pour	-80 to +20°C	6C		2C
Melting point	+32 to +127°C	61C		63C

6.2.1 Since separation of liquid column thermometers occasionally occurs and may escape detection, thermometers should be checked immediately prior to the test and used only if they prove accurate within  $\pm 1^\circ\text{C}$  (for example ice point).

6.3 *Cork*, to fit the test jar, bored centrally for the test thermometer.

6.4 *Jacket*, watertight, cylindrical, metal, flat-bottomed,  $115 \pm 3$ -mm depth, with inside diameter of 44.2 to 45.8 mm. It shall

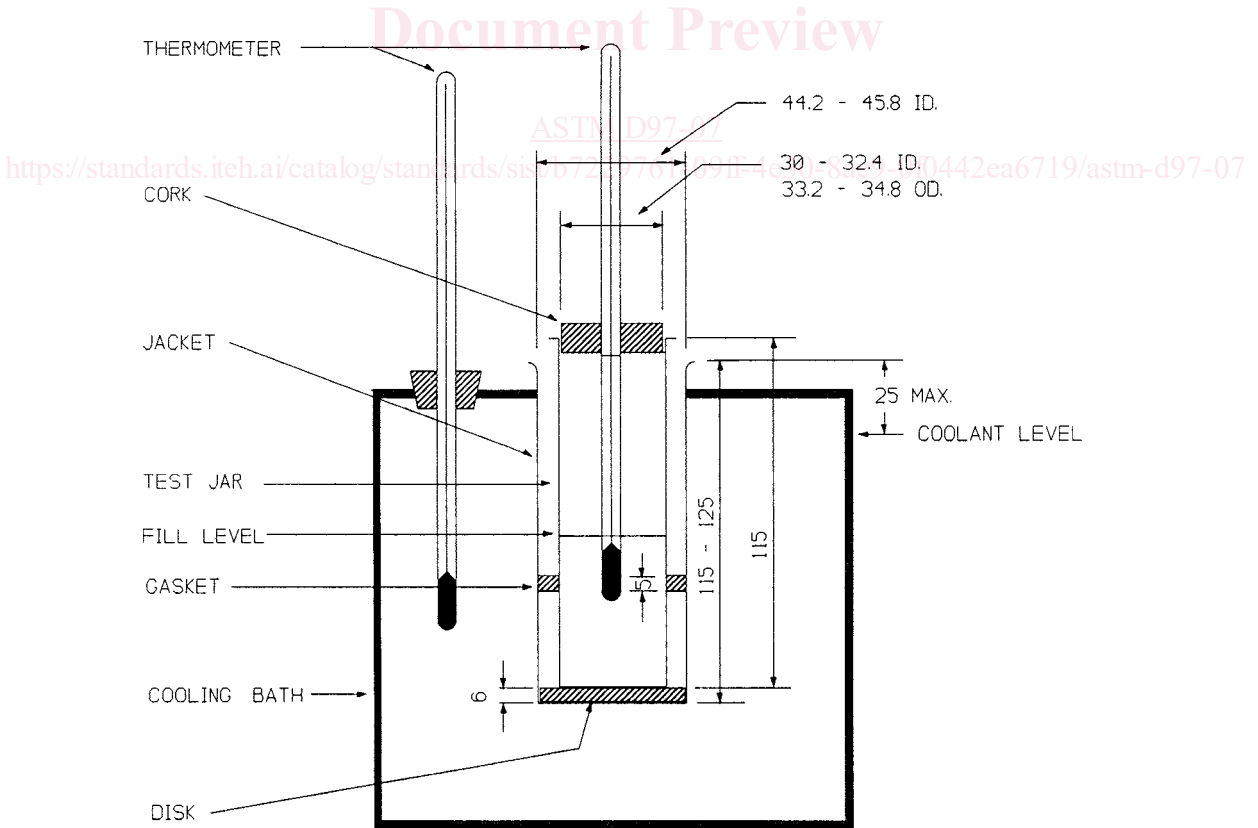

NOTE—Dimensions are in millimetres (not to scale).

**FIG. 1 Apparatus for Pour Point Test**

be supported in a vertical position in the cooling bath (see 6.7) so that not more than 25 mm projects out of the cooling medium, and shall be capable of being cleaned.

6.5 *Disk*, cork or felt, 6 mm thick to fit loosely inside the jacket.

6.6 *Gasket*, to fit snugly around the outside of the test jar and loosely inside the jacket. The gasket may be made of rubber, leather, or other material that is elastic enough to cling to the test jar and hard enough to hold its shape. Its purpose is to prevent the test jar from touching the jacket.

6.7 *Bath or Baths*, maintained at prescribed temperatures with a firm support to hold the jacket vertical. The required bath temperatures may be obtained by refrigeration if available, otherwise by suitable freezing/cooling mixtures. Freezing/Cooling mixtures commonly used for temperatures down to those shown are as follows:

	<u>For Temperatures Down Bath Temperature</u>
Ice and water	-9°C
Ice and water	$0 \pm 1.5^\circ\text{C}$
<del>Crushed ice and sodium chloride crystals</del>	<del>-12°C</del>
Crushed ice and sodium chloride crystals	$-18 \pm 1.5^\circ\text{C}$
<del>Crushed ice and calcium chloride crystals</del>	<del>-27°C</del>
Crushed ice and calcium chloride crystals	$-33 \pm 1.5^\circ\text{C}$
<del>Acetone or petroleum naphtha (see Section 7) chilled in a covered metal beaker with an ice-salt mixture to -12°C then with enough solid carbon dioxide to give the desired temperature.</del>	<del>-57°C -51 ± 1.5°C</del>
Acetone or petroleum naphtha (see Section 7) chilled in a covered metal beaker with an ice-salt mixture to -18°C then with enough solid carbon dioxide to give the desired temperature.	$-51 \pm 1.5^\circ\text{C}$
Acetone or petroleum naphtha (see Section 7) chilled in a covered metal beaker with an ice-salt mixture to -51°C then with enough solid carbon dioxide to give the desired temperature.	$-69 \pm 1.5^\circ\text{C}$

## 7. Reagents and Materials

7.1 The following solvents of technical grade are appropriate for low-temperature bath media.

- 7.1.1 *Acetone*, (**Warning**—Extremely flammable).
- 7.1.2 *Alcohol, Ethanol* (**Warning**—Flammable).
- 7.1.3 *Alcohol, Methanol* (**Warning**—Flammable. Vapor harmful).
- 7.1.4 *Petroleum Naphtha*, (**Warning**—Combustible. Vapor harmful).
- 7.1.5 *Solid Carbon Dioxide*, (**Warning**—Extremely cold -78.5°C).

## 8. Procedure

8.1 Pour the specimen into the test jar to the level mark. When necessary, heat the specimen in a bath until it is just sufficiently fluid to pour into the test jar.

NOTE 1—It is known that some materials, when heated to a temperature higher than 45°C during the preceding 24 h, do not yield the same pour point results as when they are kept at room temperature for 24 h prior to testing. Examples of materials which are known to show sensitivity to thermal history are residual fuels, black oils, and cylinder stocks.

8.1.1 Samples of residual fuels, black oils, and cylinder stocks which have been heated to a temperature higher than 45°C during the preceding 24 h, or when the thermal history of these sample types is not known, shall be kept at room temperature for 24 h before testing. Samples which are known by the operator not to be sensitive to thermal history need not be kept at room temperature for 24 h before testing.

8.1.2 Experimental evidence supporting elimination of the 24-h waiting period for some sample types is contained in a research report.<sup>6</sup>

8.2 Close the test jar with the cork carrying the high-pour thermometer (5.2). In the case of pour points above 36°C, use a higher range thermometer such as IP 63C or ASTM 61C. Adjust the position of the cork and thermometer so the cork fits tightly, the thermometer and the jar are coaxial, and the thermometer bulb is immersed so the beginning of the capillary is 3 mm below the surface of the specimen.

8.3 For the measurement of pour point, subject the specimen in the test jar to the following preliminary treatment:

8.3.1 *Specimens Having Pour Points Above -33°C*—Heat the specimen without stirring to 9°C above the expected pour point, but to at least 45°C, in a bath maintained at 12°C above the expected pour point, but at least 48°C. Transfer the test jar to a bath maintained at  $24 \pm 1.5^\circ\text{C}$  and commence observations for pour point. When using a liquid bath, ensure that the liquid level is between the fill mark on the test jar and the top of the test jar.

<sup>6</sup> Supporting data have been filed at ASTM International Headquarters and may be obtained by requesting Research Report RR: D02-1377.

8.3.2 *Specimens Having Pour Points of  $-33^{\circ}\text{C}$  and Below*—Heat the specimen without stirring to  $45^{\circ}\text{C}$  in a bath maintained at  $48 \pm 1.5^{\circ}\text{C}$  and cool to  $15^{\circ}\text{C}$  in a bath maintained at  $6 \pm 1.5^{\circ}\text{C}$ . Remove the high cloud and pour thermometer, and place the low cloud and pour thermometer in position. When using a liquid bath, ensure that the liquid level is between the fill mark on the test jar and the top of the test jar. —Heat the specimen without stirring to at least  $45^{\circ}\text{C}$  in a bath maintained at  $48 \pm 1.5^{\circ}\text{C}$ . Transfer the test jar to a bath maintained at  $24 \pm 1.5^{\circ}\text{C}$ . When using a liquid bath, ensure that the liquid level is between the fill mark on the test jar and the top of the test jar. When the specimen temperature reaches  $27^{\circ}\text{C}$ , remove the high cloud and pour thermometer, and place the low cloud and pour thermometer in position. Transfer the test jar to the cooling bath (see 8.6.1).

8.4 See that the disk, gasket, and the inside of the jacket are clean and dry. Place the disk in the bottom of the jacket. Place the gasket around the test jar, 25 mm from the bottom. Insert the test jar in the jacket. Never place a jar directly into the cooling medium.

8.5 After the specimen has cooled to allow the formation of paraffin wax crystals, take great care not to disturb the mass of specimen nor permit the thermometer to shift in the specimen; any disturbance of the spongy network of wax crystals will lead to low and erroneous results.

8.6 Pour points are expressed in integers that are positive or negative multiples of  $3^{\circ}\text{C}$ . Begin to examine the appearance of the specimen when the temperature of the specimen is  $9^{\circ}\text{C}$  above the expected pour point (estimated as a multiple of  $3^{\circ}\text{C}$ ). At each test thermometer reading that is a multiple of  $3^{\circ}\text{C}$  below the starting temperature remove the test jar from the jacket. To remove condensed moisture that limits visibility wipe the surface with a clean cloth moistened in alcohol (ethanol or methanol). Tilt the jar just enough to ascertain whether there is a movement of the specimen in the test jar. If movement of specimen in the test jar is noted, then replace the test jar immediately in the jacket and repeat a test for flow at the next temperature,  $3^{\circ}\text{C}$  lower. Typically, the complete operation of removal, wiping, and replacement shall require not more than 3 s.

8.6.1 If the specimen has not ceased to flow when its temperature has reached  $27^{\circ}\text{C}$ , transfer the test jar to a jacket in a cooling bath maintained at  $0 \pm 1.5^{\circ}\text{C}$ . As the specimen continues to get colder, transfer the test jar to a jacket in the next lower temperature cooling bath in accordance with Table 1.

8.6.2 If the specimen in the jar does not show movement when tilted, hold the jar in a horizontal position for 5 s, as noted by an accurate timing device, and observe the specimen carefully. If the specimen shows any signs of movement before 5 s has passed, replace the test jar immediately in the jacket and repeat a test for flow at the next temperature,  $3^{\circ}\text{C}$  lower.

8.7 Continue in this manner until a point is reached at which the specimen shows no movement when the test jar is held in a horizontal position for 5 s. Record the observed reading of the test thermometer.

8.8 For black specimen, cylinder stock, and nondistillate fuel specimen, the result obtained by the procedure described in 8.1 through 8.7 is the upper (maximum) pour point. If required, determine the lower (minimum) pour point by heating the sample while stirring, to  $105^{\circ}\text{C}$ , pouring it into the jar, and determining the pour point as described in 8.4 through 8.7.

8.9 Some specifications allow for a pass/fail test or have pour point limits at temperatures not divisible by  $3^{\circ}\text{C}$ . In these cases, it is acceptable practice to conduct the pour point measurement according to the following schedule: Begin to examine the appearance of the specimen when the temperature of the specimen is  $9^{\circ}\text{C}$  above the specification pour point. Continue observations at  $3^{\circ}\text{C}$  intervals as described in 8.6 and 8.7 until the specification temperature is reached. Report the sample as passing or failing the specification limit.

## 9. Calculation and Report

9.1 Add  $3^{\circ}\text{C}$  to the temperature recorded in 8.7 and report the result as the Pour Point, ASTM D 97. For black oil, and so forth, add  $3^{\circ}\text{C}$  to the temperature recorded in 8.7 and report the result as Upper Pour Point, ASTM D 97, or Lower Pour Point, ASTM D 97, as required.

## 10. Precision and Bias

10.1 *Precision*—The precision of this test method as determined by the statistical examination of the interlaboratory test results is as follows:

### 10.1.1 *Lubricating Oil*<sup>7</sup>:

<sup>7</sup> Supporting data (the results of the 1998 interlaboratory cooperative test program) have been filed at ASTM International Headquarters and may be obtained by requesting Research Report RR: D02-1499.

**TABLE 1 Bath and Sample Temperature Ranges**

Bath	Bath Temperature Setting, $^{\circ}\text{C}$	Sample Temperature Range, $^{\circ}\text{C}$
1	$0 \pm 1.5$	Start to 9
2	$-18 \pm 1.5$	9 to -6
3	$-33 \pm 1.5$	-6 to -24
4	$-51 \pm 1.5$	-24 to -42
5	$-69 \pm 1.5$	-42 to -60

10.1.1.1 *Repeatability*—The difference between successive test results, obtained by the same operator using the same apparatus under constant operating conditions on identical test material would, in the long run, in the normal and correct operation of this test method, exceed 6°C only in one case in twenty. Differences greater than this should be considered suspect.

10.1.1.2 *Reproducibility*—The difference between two single and independent test results, obtained by different operators working in different laboratories on identical test material would, in the long run, in the normal and correct operation of this test method, exceed 9°C only in one case in twenty. Differences greater than this should be considered suspect.

10.1.1.3 The precision statements<sup>7</sup> were derived from a 1998 interlaboratory test program using Practice D 6300. Participants analyzed five sets of duplicate base oils, three sets of duplicate multigrade lubricating oils, and one set each of duplicate hydraulic oils and automatic transmission fluid in the temperature range of -51 to -11°C. Seven laboratories participated with the manual Test Method D 97. Information on the type of samples and their average pour points are in Research Report RR:D02-1499.<sup>7</sup>

NOTE 2—The precision statements are the derived values rounded up to the next testing interval value. The actual derived precision values appear in Table X2.1.

#### 10.1.2 *Middle Distillate and Residual Fuel*<sup>8</sup>:

10.1.2.1 *Repeatability*—The difference between successive test results obtained by the same operator using the same apparatus under constant operation conditions on identical test material would, in the long run, in the normal and correct operation of this test method, exceed 3°C only in one case in twenty. Differences greater than this should be considered suspect.

10.1.2.2 *Reproducibility*—The difference between two single and independent test results, obtained by different operators working in different laboratories on identical test material would, in the long run, in the normal and correct operation of this test method, exceed 9°C only in one case in twenty. Differences greater than this should be considered suspect.

10.1.2.3 The precision statements<sup>8</sup> were prepared with data on sixteen middle distillate and residual fuels tested by twelve cooperators. The fuels had pour points ranging from -33 to +51°C.

NOTE 3—The precision statements are the derived values rounded up to the next testing interval value. The actual derived precision values can be seen in Table X2.1.

NOTE 4—The precisions in 10.1.2 are not known to have been derived using Practice D 6300.

10.2 *Bias*—There being no criteria for measuring bias in these test-product combinations, no statement of bias can be made.

## APPENDIXES

(Nonmandatory Information)

### X1. TEST FOR FLUIDITY OF A RESIDUAL FUEL OIL AT A SPECIFIED TEMPERATURE

#### X1.1 General

X1.1.1 The low-temperature flow properties of a waxy fuel oil depend on handling and storage conditions. Thus, they may not be truly indicated by pour point. The pour point test does not indicate what happens when an oil has a considerable head of pressure behind it, such as when gravitating from a storage tank or being pumped along a pipeline. Failure to flow at the pour point is normally attributed to the separation of wax from the fuel; however, it can also be due to the effect of viscosity in the case of very viscous fuel oils. In addition pour points of residual fuels are influenced by the previous thermal history of the specimens. A loosely knit wax structure built up on cooling of the oil can be normally broken by the application of relatively little pressure.

X1.1.2 The usefulness of the pour point test in relation to residual fuel oils is open to question, and the tendency to regard the pour point as the limiting temperature at which a fuel will flow can be misleading. The problem of accurately specifying the handling behavior of fuel oil is important, and because of the technical limitations of the pour point test, various pumpability tests have been devised to assess the low-temperature flow characteristics of heavy residual fuel oils. Test Method D 3245 is one such method. However, most alternative methods tend to be time-consuming and as such do not find ready acceptance as routine control tests for determining low-temperature flow properties. One method which is relatively quick and easy to perform and has found limited acceptance as a “go-no-go” method is based on the appendix method to the former Test Method D 1659-65. The method is described as follows.

#### X1.2 Scope

X1.2.1 This method covers the determination of the fluidity of a residual fuel oil at a specified temperature in an as-received condition.

#### X1.3 Definition

X1.3.1 *fluidity temperature*—the sample when tested in an as-received condition is considered “fluid at the temperature of the test” if it will flow 2 mm in 1 min in a 12.5 mm U-tube under a maximum pressure of 152 mm of mercury.

<sup>8</sup> Based on the results of the 1983 interlaboratory cooperative test program.

## X1.4 Summary of Test Method

X1.4.1 A sample of fuel in its as-received condition is cooled at the specified temperature for 30 min in the standard U-tube and is tested for movement under prescribed pressure conditions.

## X1.5 Significance and Use

X1.5.1 This method may be used as a “go-no-go” procedure for operational situations where it is necessary to ascertain the fluidity of a residual oil under prescribed conditions in an as-received condition. The conditions of this method simulate those of a pumping situation where the oil is expected to flow through a 12-mm pipe under slight pressure at a specified temperature. Fluidity, like Test Method D 97, is used to define cold flow properties. It differs from D 97, however, in that (1) it is restricted to residual fuel oil and (2) a prescribed pressure is applied to the sample. The latter represents an attempt to overcome the technical limitations of the Pour Point Method where gravity-induced flow is the criterion. Test Method D 3245, represents another method for predicting field performance in cold flow conditions. Test Method D 3245, however, does have limitations and may not be suitable for use with very waxy fuel oils which solidify so rapidly in the chilling bath that a reading cannot be obtained under the conditions of the test. It is also a time-consuming test and therefore not suitable for routine control testing.

## X1.6 Apparatus

X1.6.1 *Glass U-Tubes*, 150 mm high, having a uniform internal diameter of  $12.5 \pm 1$  mm and a radius of curvature, measured to the outside curve of the tube of 35 mm (Fig. X1.1).

X1.6.2 *Thermometers*—Thermometers having a range from  $-38$  to  $+50^{\circ}\text{C}$  and conforming to the requirements of Thermometer 5C as prescribed in Specification E 1, shall be used for insertion in the glass U-tubes and for measuring the temperatures of the baths.

X1.6.3 *Fluidity Temperature Test Bath*,<sup>9</sup>

consists of a reservoir, a stirrer, and a motor and pump to circulate coolant through the coils of the tubing placed in the bottom of the test bath and passing through the cold bath. The flow of coolant through these coils can be controlled by a thermostat and a solenoid valve. It is possible that, where justified by the quantity of work, more than one such bath could be utilized to permit concurrent testing at more than one temperature (Fig. X1.2).

X1.6.4 *Mercury Manometer* calibrated in 10-mm divisions with a distinguishing mark at 152 mm (equivalent to 20.3 kPa).

X1.6.5 *Automatic Vacuum Controller*<sup>10</sup> (as shown in Fig. X1.3 and Fig. X1.4) —A device that gradually increased the vacuum applied to one end of the U-tube at the specified rate of 10 mm/4S.

## X1.7 Preparation of Apparatus

X1.7.1 Adjust the automatic vacuum controller as follows: close the stopcock on the tube connecting the automatic vacuum controller to the fluidity tester. A pinchcock on the rubber tube will serve as well as a stopcock. Wind the thread attached to the steel rod around the pulley on the synchronous motor until the end of the rod is about 15 mm above the zero level of the mercury in the control manometer. Turn on the power switch. The thread will begin to unwind, lowering the steel rod. When the rod contacts the mercury, the relay will open the solenoid valve in the vacuum line and air will be pumped from the system at a rate limited by the needle valve. Adjust this needle valve until the descending mercury in the control manometer just leads the rod, reducing the relay operation to a minimum. When properly adjusted, the pulsations caused by the opening and closing of the solenoid valve should not exceed  $\pm 1$  mm. In this manner the pressure in the system will be reduced gradually at a rate governed by the descent of the steel rod.

## X1.8 Procedure

X1.8.1 Pour the sample as received into a thoroughly cleaned and dry standard fluidity U-tube, without contacting the upper walls of the tube, until the vertical height of the sample in the U-tube is 38 mm. Insert in one leg of each U-tube an ASTM Thermometer 5C in a cork that has been grooved to permit the passage of air. The thermometer must be placed in the center of the tube and its bulb immersed so that the beginning of the capillary is 3 mm below the surface of the specimen.

X1.8.2 Fix the tube in the bath set at the specific temperature, immersed to a depth of approximately 75 mm. Control the bath and sample temperatures within  $\pm 1^{\circ}\text{C}$  and  $\pm 0.5^{\circ}\text{C}$ , respectively, of the specified temperature of the test.

X1.8.3 Maintain the sample at the specified temperature for  $30 \text{ min} \pm 30 \text{ s}$ , with the U-tube connected to the automatic vacuum controller, and the stopcock or pinch-clamp open. Wind the thread on the pulley attached to the synchronous motor. Turn the power switch to the ON position. Apply suction automatically to the U-tube at the prescribed rate. Observe any movement of the specimen during a one-minute interval which is the time required to apply 152-mm Hg vacuum to the specimen in the U-tube. Immediately disconnect the U-tube from the automatic vacuum controller, turn off the power switch and rewind the thread. If the specimen has moved 2 mm or more during the time (1 min) the suction was applied, the specimen is considered fluid at the temperature of the test.

<sup>9</sup> A kinematic viscosity bath is usually satisfactory.

<sup>10</sup> This apparatus may be shop fabricated. Details of special parts are indicated in Figs. X1.3 and X1.4. Alternatively, the apparatus can be purchased.