

ETSI TS 103 713 V15.0.0 (2019-11)



Smart Secure Platform (SSP); SPI interface (Release 15)

iTeh STANDARDS REVIEW
(standards.iteh.ai)
Full standard: <https://standards.iteh.ai/catalog/standards/sst/bts/103-713-v15.0.0-2019-11>
4e71-8937-94bb419859e0/etsi-ts-103-713-v15.0.0-2019-11

ReferenceDTS/SCP-T103713vf00

KeywordsM2M, MFF

ETSI

650 Route des Lucioles
F-06921 Sophia Antipolis Cedex - FRANCE

Tel.: +33 4 92 94 42 00 Fax: +33 4 93 65 47 16

Siret N° 348 623 562 00017 - NAF 742 C
Association à but non lucratif enregistrée à la
Sous-Préfecture de Grasse (06) N° 7803/88

Important notice

The present document can be downloaded from:

<http://www.etsi.org/standards-search>

The present document may be made available in electronic versions and/or in print. The content of any electronic and/or print versions of the present document shall not be modified without the prior written authorization of ETSI. In case of any existing or perceived difference in contents between such versions and/or in print, the prevailing version of an ETSI deliverable is the one made publicly available in PDF format at www.etsi.org/deliver.

Users of the present document should be aware that the document may be subject to revision or change of status. Information on the current status of this and other ETSI documents is available at

<https://portal.etsi.org/TB/ETSIDeliverableStatus.aspx>

If you find errors in the present document, please send your comment to one of the following services:

<https://portal.etsi.org/People/CommiteeSupportStaff.aspx>

Copyright Notification

No part may be reproduced or utilized in any form or by any means, electronic or mechanical, including photocopying and microfilm except as authorized by written permission of ETSI.

The content of the PDF version shall not be modified without the written authorization of ETSI.

The copyright and the foregoing restriction extend to reproduction in all media.

© ETSI 2019.

All rights reserved.

DECT™, **PLUGTESTS™**, **UMTS™** and the ETSI logo are trademarks of ETSI registered for the benefit of its Members.

3GPP™ and **LTE™** are trademarks of ETSI registered for the benefit of its Members and of the 3GPP Organizational Partners.

oneM2M™ logo is a trademark of ETSI registered for the benefit of its Members and of the oneM2M Partners.

GSM® and the GSM logo are trademarks registered and owned by the GSM Association.

Contents

Intellectual Property Rights	5
Foreword.....	5
Modal verbs terminology.....	5
1 Scope	6
2 References	6
2.1 Normative references	6
2.2 Informative references.....	6
3 Definition of terms, symbols and abbreviations.....	7
3.1 Terms.....	7
3.2 Symbols.....	7
3.3 Abbreviations	7
4 Introduction	8
5 SCL Under-Layers Protocol Stack	8
6 Electrical interfaces	9
6.1 Introduction	9
6.2 Physical interface with 5 signals	9
6.3 Physical interface with 4 signals	10
6.4 Electrical characteristics.....	11
6.4.1 DC characteristics.....	11
6.4.2 Data transfer mode, AC characteristics.....	11
7 Data Link Layer	12
7.1 Overview	12
7.2 MAC Layer	12
7.2.1 Overview	12
7.2.2 Timing	13
7.2.2.1 Timing definitions.....	13
7.2.2.2 T1 = Slave Ready Time.....	13
7.2.2.3 T2 = Slave Request Time.....	13
7.2.3 5 signals MAC layer	14
7.2.3.1 Initiation of the data transfer from the master.....	14
7.2.3.2 Initiation of the data transfer from the slave	14
7.2.3.3 Simultaneous initiation of a data transfer from both master and slave.....	15
7.2.3.4 MAC activation.....	15
7.2.3.5 MAC deactivation.....	15
7.2.4 4 signals MAC layer	15
7.2.4.1 Introduction.....	15
7.2.4.2 Initiation of the data transfer from the master.....	16
7.2.4.3 Initiation of the data transfer from the slave	16
7.2.4.4 Simultaneous initiation of the data transfer from both master and slave.....	17
7.2.4.5 Slave-driven Flow Control.....	17
7.2.4.6 MAC activation.....	18
7.2.4.7 MAC deactivation.....	18
7.3 Link Layer Frame	18
7.3.1 Overview	18
7.3.2 Frames generation and transfer rules	19
7.4 LLC layers.....	22
7.5 Interworking of the LLC layers.....	23
7.6 MCT LLC definition	23
7.6.1 MCT LPDU structure	23
7.6.2 MCT_DATA from master	24
7.6.3 MCT_DATA from slave.....	25
7.6.4 MCT activation procedure	26

7.7 SHDLC LLC definition.....26

7.7.1 SHDLC overview26

7.7.2 Endpoints26

7.7.3 Flow control.....27

7.7.3.1 Overview.....27

7.7.3.2 Flow control based on SHDLC27

Annex A (informative): Change history28

History29

iTeh STANDARD PREVIEW
(standards.iteh.ai)
Full standard:
<https://standards.iteh.ai/catalog/standards/sist/b39da69-4ea2-4e71-8937-94bb419859e0/etsi-ts-103-713-v15.0.0-2019-11>

Intellectual Property Rights

Essential patents

IPRs essential or potentially essential to normative deliverables may have been declared to ETSI. The information pertaining to these essential IPRs, if any, is publicly available for **ETSI members and non-members**, and can be found in ETSI SR 000 314: "*Intellectual Property Rights (IPRs); Essential, or potentially Essential, IPRs notified to ETSI in respect of ETSI standards*", which is available from the ETSI Secretariat. Latest updates are available on the ETSI Web server (<https://ipr.etsi.org/>).

Pursuant to the ETSI IPR Policy, no investigation, including IPR searches, has been carried out by ETSI. No guarantee can be given as to the existence of other IPRs not referenced in ETSI SR 000 314 (or the updates on the ETSI Web server) which are, or may be, or may become, essential to the present document.

Trademarks

The present document may include trademarks and/or tradenames which are asserted and/or registered by their owners. ETSI claims no ownership of these except for any which are indicated as being the property of ETSI, and conveys no right to use or reproduce any trademark and/or tradename. Mention of those trademarks in the present document does not constitute an endorsement by ETSI of products, services or organizations associated with those trademarks.

Foreword

This Technical Specification (TS) has been produced by ETSI Technical Committee Smart Card Platform (SCP).

The contents of the present document are subject to continuing work within TC SCP and may change following formal TC SCP approval. If TC SCP modifies the contents of the present document, it will then be republished by ETSI with an identifying change of release date and an increase in version number as follows:

Version x.y.z

where:

- x the first digit:
 - 0 early working draft;
 - 1 presented to TC SCP for information;
 - 2 presented to TC SCP for approval;
 - 3 or greater indicates TC SCP approved document under change control.
- y the second digit is incremented for all changes of substance, i.e. technical enhancements, corrections, updates, etc.
- z the third digit is incremented when editorial only changes have been incorporated in the document.

Modal verbs terminology

In the present document "**shall**", "**shall not**", "**should**", "**should not**", "**may**", "**need not**", "**will**", "**will not**", "**can**" and "**cannot**" are to be interpreted as described in clause 3.2 of the [ETSI Drafting Rules](#) (Verbal forms for the expression of provisions).

"**must**" and "**must not**" are **NOT** allowed in ETSI deliverables except when used in direct citation.

1 Scope

The present document describes the SPI interface for the communication of an SSP, as defined in ETSI TS 103 666-1 [1] using the SCL protocol.

2 References

2.1 Normative references

References are either specific (identified by date of publication and/or edition number or version number) or non-specific. For specific references, only the cited version applies. For non-specific references, the latest version of the referenced document (including any amendments) applies.

- In the case of a reference to a TC SCP document, a non-specific reference implicitly refers to the latest version of that document in the same Release as the present document.

Referenced documents which are not found to be publicly available in the expected location might be found at <https://docbox.etsi.org/Reference/>.

NOTE: While any hyperlinks included in this clause were valid at the time of publication, ETSI cannot guarantee their long term validity.

The following referenced documents are necessary for the application of the present document.

- [1] ETSI TS 103 666-1: "Smart Secure Platform (SSP); Part 1: General characteristics".
- [2] ETSI TS 102 613: "Smart Cards; UICC - Contactless Front-end (CLF) Interface; Physical and data link layer characteristics".
- [3] ISO/IEC 13239: "Information Technology -- Telecommunications and information exchange between systems -- High-level Data Link Control (HDLC) procedures".

2.2 Informative references

References are either specific (identified by date of publication and/or edition number or version number) or non-specific. For specific references, only the cited version applies. For non-specific references, the latest version of the referenced document (including any amendments) applies.

- In the case of a reference to a TC SCP document, a non-specific reference implicitly refers to the latest version of that document in the same Release as the present document.

NOTE: While any hyperlinks included in this clause were valid at the time of publication, ETSI cannot guarantee their long term validity.

The following referenced documents are not necessary for the application of the present document but they assist the user with regard to a particular subject area.

- [i.1] ETSI TR 102 216: "Smart cards; Vocabulary for Smart Card Platform specifications".

3 Definition of terms, symbols and abbreviations

3.1 Terms

For the purposes of the present document, the terms given in ETSI TR 102 216 [i.1] and the following apply:

data transfer: information exchange during an SPI access between the master and the slave with SPI_MISO driven by the slave and SPI_MOSI driven by the master while the master is toggling the SPI_CLK signal

flow control: mechanism part of the Data Link Layer that consists of methods applied by transmitter in order to send at any time a number of logical data units that can be accepted by receiver

frame: link layer data structure consisting of a prologue or frame header, payload and epilogue or trailer usually containing the CRC bytes

MAC access request: request from the slave to the master for a data transfer, i.e. a MAC phase initiated by the slave

MAC phase: initiation of a data transfer by the master and/or request for a data transfer by the slave

SPI access: SPI_NSS assertion by the master, if not already asserted in the MAC phase, followed by SPI_CLK start for transferring a certain number of bytes according to the SPI master configuration

NOTE: The number of bytes transferred during an SPI access is always the same in both directions on SPI_MISO and SPI_MOSI and is also referred to as access length.

window size: maximum number of logical data units that can be sent from transmitter to receiver without any link layer acknowledgements for any of these data units

window size slot: fixed space allocated by slave in the receive buffer for the logical data units used for windows size definition

NOTE: The length of a window size slot equals Data Link Layer MTU.

3.2 Symbols

Void.

3.3 Abbreviations

For the purposes of the present document, the following abbreviations apply:

AC	Alternating Current
ACT	Activation
CLF	ContactLess Frontend
CMD	Command
CPHA	Clock Phase
CPOL	Clock Polarity
CRC	Cyclic Redundancy Check
DC	Direct Current
DLL	Data Link Layer
FIFO	First In, First Out
IO	Input/Output
IOH	High Output Current (Output current corresponding to VOH)
IOL	Low Output Current (Output current corresponding to VOL)
LLC	Logical Link Control
LPDU	Link Protocol Data Unit
MAC	Medium Access Control
MCT	MAC aCTivation
MISO	Master Input Slave Output
MOSI	Master Output Slave Input

MTU	Maximum Transmission Unit
NSD	Non-Significant Data
OD	Open Drain
RFU	Reserved for Future Use
SCL	SSP Common Layer
SHDLC	Simplified High Level Data Link Control
SPI	Serial Peripheral Interface
SSP	Smart Secure Platform
SWP	Single Wire Protocol

NOTE: Defined in ETSI TS 102 613 [2].

VDD	Supply Voltage
VIH	High Input Voltage (Input Voltage for High Logic Level)
VIL	Low Input Voltage (Input Voltage for Low Logic Level)
VOH	High Output Voltage (Output Voltage for High Logic Level)
VOL	Low Output Voltage (Output Voltage for Low Logic Level)

4 Introduction

The Serial Peripheral Interface (SPI) is a serial synchronous full-duplex communication interface between a single master and one or more slaves present on the same SPI bus, each slave being selected at one time by a dedicated SPI_NSS signal. This clause defines the physical, MAC and data link layers for the SPI interface.

In this clause the terms master and slave refer respectively to the terms master SPI and slave SPI.

5 SCL Under-Layers Protocol Stack

Figure 5.1 illustrates the protocol stack below the SCL supporting the SPI interface.

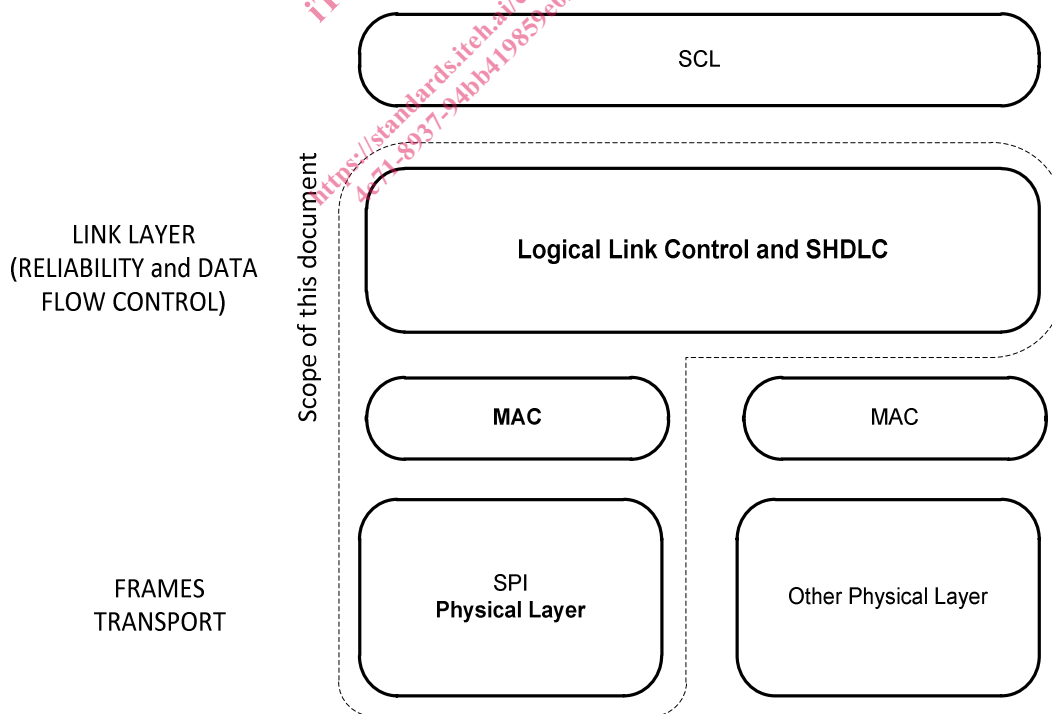

Figure 5.1: Protocol stack for SPI Interface

6 Electrical interfaces

6.1 Introduction

In the clauses below, different implementations of SPI interface are defined. These implementations allow bi-directional communication and the possibility for the slave to initiate communication with the master when it has data available thus avoiding the necessity for continuous polling to be performed by master.

Slave may initiate communication to send a command without a prior command from master.

6.2 Physical interface with 5 signals

Figure 6.1 illustrates the SPI electrical interface using 5 signals.

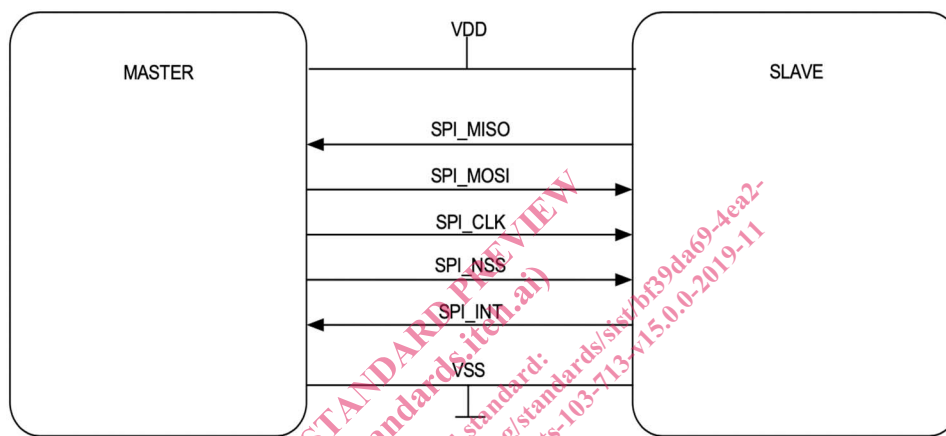

Figure 6.1: SPI electrical interface with 5 signals

This SPI interface describes two sets of signals:

- The generic and legacy SPI interface using the 4 signals: SPI_MOSI (Master Output Slave Input), SPI_MISO (Master Input Slave Output), SPI_CLK (clock) and the SPI_NSS signal used for the selection of a Slave Endpoint among N slaves sharing the same bus. SPI_MISO, SPI_MOSI and SPI_CLK can be shared between several SPI slaves present on the same SPI bus.
- The SPI_INT signal allows the slave to initiate a MAC access request in order to notify the master to start a data transfer.

SPI_INT signal is considered active or asserted at high voltage level.

SPI_NSS is considered active or asserted at low voltage level.

6.3 Physical interface with 4 signals

Figure 6.2 illustrates the SPI interface using 4 signals, bi-directional SPI_NSS.

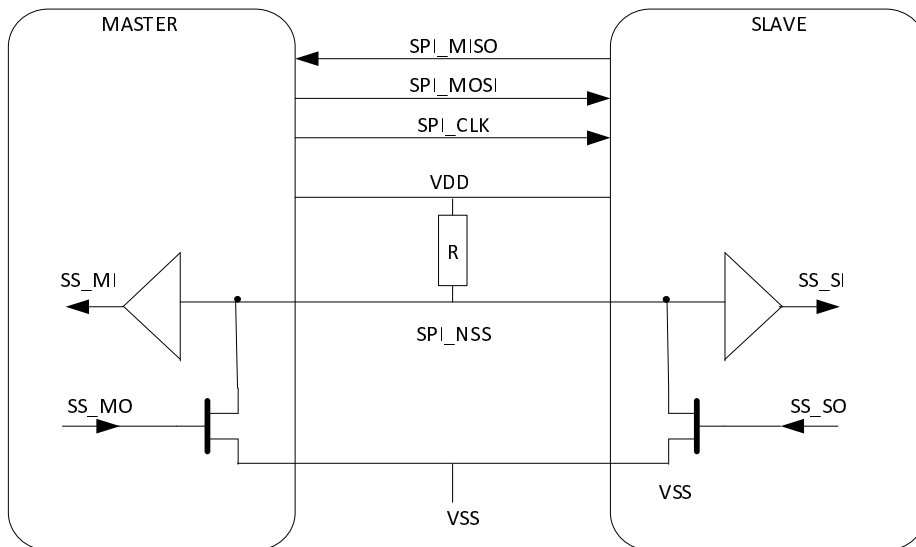

Figure 6.2: SPI electrical interface with 4 signals, bi-directional SPI_NSS

The SPI interface with 4 signals describes two sets of signals:

- The three generic and legacy SPI signals as SPI_MOSI (Master Output Slave Input), SPI_MISO (Master Input Slave Output) and SPI_CLK (clock). These signals can be shared between several SPI slaves as a bus.
- The SPI_NSS (Negative Slave Select) signal used for the selection of a slave endpoint among N slaves sharing the same bus and for the slave to initiate a MAC access request to notify the master to initiate a data transfer.

SPI_NSS is considered active or asserted at low voltage level. SPI_NSS requires a bidirectional IO implementing an Open Drain (OD) interface for both master and slave. This configuration allows driving the SPI_NSS signal to low voltage level by both master and slave without electrical contention.

A pull-up resistor allows to keep SPI_NSS at high state level (i.e. idle state) when SS_MO and SS_SO are not asserted. The SPI_NSS signal is at low state when either SS_MO or SS_SO are asserted.

NOTE: Despite the current industry de-facto SPI specification which defines SPI_NSS signal as unidirectional, driven by the master, in the present document the SPI_NSS in the 4 signals configuration is bidirectional.

Table 6.1: Definition of the signals

Signal	Description
SS_MO	Internal master output signal for SPI_NSS assertion. SS_MO is at high state level for generating a SPI_NSS signal assertion (i.e. low level state)
SS_SO	Internal slave output signal for SPI_NSS assertion. SS_SO is at high state level for generating a SPI_NSS signal assertion (i.e. low level state)
SS_MI	Internal master input signal indicating SPI_NSS status. SS_MI is at high state level when the SPI_NSS signal is not asserted
SS_SI	Internal slave input signal indicating SPI_NSS status. SS_SI is at high state level when the SPI_NSS signal is not asserted
SPI_NSS	SPI_NSS signal: low state level when asserted