



Standard Test Method for Evaluation of Carpet Embedded Dirt Removal Effectiveness of Household/Commercial Vacuum Cleaners¹

This standard is issued under the fixed designation F 608; the number immediately following the designation indicates the year of original adoption or, in the case of revision, the year of last revision. A number in parentheses indicates the year of last reapproval. A superscript epsilon (ϵ) indicates an editorial change since the last revision or reapproval.

1. Scope

1.1 This test method covers only a laboratory test for determining the relative carpet dirt removal effectiveness of household/commercial vacuum cleaners when tested under specified conditions.

1.2 This test method is applicable to household/commercial types of upright, canister, and combination cleaners.

1.3 The test method applies to embedded dirt removal from carpets, not the removal of surface litter and debris.

1.4

1.4 The values stated in inch-pound units are to be regarded as standard. The values given in parentheses are mathematical conversions to SI units that are provided for information only and are not considered standard.

1.5 This standard does not purport to address all of the safety concerns, if any, associated with its use. It is the responsibility of the user of this standard to establish appropriate safety and health practices and determine the applicability of regulatory limitations prior to use.

2. Referenced Documents

2.1 ASTM Standards:²

D 75 Practice for Sampling Aggregates

E 11 Specification for Wire Cloth and Sieves for Testing Purposes

E 177 Practice for Use of the Terms Precision and Bias in ASTM Test Methods

E 691 Practice for Conducting an Interlaboratory Study to Determine the Precision of a Test Method

F 655 Specification for Test Carpets and Pads for Vacuum Cleaner Testing

F884 Test Method for Motor Life Evaluation of a Built-In (Central Vacuum) Vacuum Cleaner⁴

F922 Test Method for Motor Life Evaluation of an Electric Motorized Nozzle⁴ 884 Test Method for Motor Life Evaluation of a Built-In (Central Vacuum) Vacuum Cleaner

F1038 Test Method for Motor Life Evaluation of a Canister, Hand-held, Stick, and Utility Type Vacuum Cleaner Without a Driven Agitator⁴ 922 Test Method for Motor Life Evaluation of an Electric Motorized Nozzle

F1334 Test Method for Determining A-Weighted Sound Power Level of Vacuum Cleaners⁴ 1038 Test Method for Motor Life Evaluation of a Canister, Hand-held, Stick, and Utility Type Vacuum Cleaner Without a Driven Agitator

F 1334 Test Method for Determining A-Weighted Sound Power Level of Vacuum Cleaners

F 1409 Test Method for Straight-Line Movement of Vacuum Cleaners While Cleaning Carpets

3. Terminology

3.1 Definitions:

3.1.1 *cleaning ability, dry, n*—the potential of a vacuum cleaner to remove dirt from a surface (sometimes referred to in the industry as *cleanability, dry*).

3.1.2 *model, n*—the designation of a group of vacuum cleaners having identical mechanical and electrical construction with only cosmetic or nonfunctional differences.

3.1.3 *population, n*—the total of all units of a particular model vacuum cleaner being tested.

3.1.4 *repeatability limit, r*—the value below which the absolute difference between two individual test results obtained under repeatability condition may be expected to occur with a probability of approximately 0.95 (95 %).

3.1.5 *repeatability standard deviation, S_r*—the standard deviation of test results obtained under repeatability conditions.

¹ This test method is under the jurisdiction of ASTM Committee F11 on Vacuum Cleaners and is the direct responsibility of Subcommittee F11.21 on Cleanability. Current edition approved Oct. 1, 2003. Published October 2003. Originally approved in 1979. Last previous edition approved in 2001 as F608–01.

Current edition approved Dec. 15, 2007. Published January 2008. Originally approved in 1979. Last previous edition approved in 2003 as F 608 – 03.

² For referenced ASTM standards, visit the ASTM website, www.astm.org, or contact ASTM Customer Service at service@astm.org. For *Annual Book of ASTM Standards*, Vol 04.03, volume information, refer to the standard's Document Summary page on the ASTM website.

3.1.6 *reproducibility limit, R*—the value below which the absolute difference between two test results obtained under reproducibility conditions may be expected to occur with a probability of approximately 0.95 (95 %).

3.1.7 *reproducibility standard deviation, S_R*—the standard deviation of test results obtained under reproducibility conditions.

3.1.8 *sample, n*—a group of vacuum cleaners taken from a large collection of vacuum cleaners of one particular model which serves to provide information that may be used as a basis for making a decision concerning the larger collection.

3.1.9 *test run, n*—the definitive procedure that produces a singular measured result.

3.1.10 *unit, n*—a single vacuum cleaner of the model being tested.

4. Significance and Use

4.1 This test method provides an indication of the capability of the vacuum cleaner to remove embedded dirt from carpeting. This test method is based upon results of home cleaning tests so that, in most cases, a reasonable correlation exists between home and laboratory results. The amount of dirt picked up in the laboratory test may not be the same as in the home; however, it will show that, in most cases, a vacuum cleaner that performs well in the laboratory will perform well in a home. Laboratory results may differ due to variations in the homes, carpets, dirt, and other factors (see Section 6).

4.2 In order to provide a uniform basis for measuring the performance described in 1.1, standardized test carpets and a standardized test dirt are employed in this procedure.

5. Apparatus

5.1 *Weighing Scale for Weighing Carpets*, accurate to 0.035 oz (1 g) and having a weighing capacity of at least 15 lb (6.82 kg).³

5.2 *Weighing Scale (for Weighing Test Dirt and Dirt Container)*, (see ~~10.2.1.2~~, (see 9.2.2.1(2)), accurate to 0.0035 oz (0.10 g) and having a weighing capacity of at least 1.1 lb (500 g).⁴

5.3 *Stopwatch*, with a second hand or other type of equipment capable of establishing the specified rate of movement and total cycle time.

5.4 *Voltmeter*, to measure input volts to the vacuum cleaner, to provide measurements accurate to within ± 1 %.

5.5 *Voltage-Regulator System*, to control the input voltage to the vacuum cleaner. The regulator shall be capable of maintaining the vacuum cleaner's rated voltage ± 1 % and rated frequency having a wave form that is essentially sinusoidal with 3 % maximum harmonic distortion for the duration of the test.

5.6 *Dirt Embedment Tool*, with the roller locked (see ~~Fig. 1~~Fig. 3).

5.7 *Dirt Dispenser*—Dispensing system that provides the operator with a method to distribute the test dirt *uniformly* on the carpet test area.

5.8 *Carpet-Conditioning Equipment*, to support the test carpet during new carpet conditioning and the removal of residual dirt from the test carpet before each test run (Fig. ~~24~~).

5.9 *Rotating Agitator Conditioning Vacuum Cleaner/Equipment*, for conditioning new test carpets and removing residual dirt from the test carpet before each test run. This cannot be the unit being tested.

NOTE 1—Automated methods for spreading the test dirt, embedding the test dirt, and cleaning and reconditioning the test carpets are acceptable if they do not change the results of this test method.

5.10 *Temperature and Humidity Indicators*, to provide temperature measurements accurate to within $\pm 1^\circ\text{F}$ ($\pm \frac{1}{2}^\circ\text{C}$) and humidity measurements accurate to within 2 % relative humidity.

5.11 *Supporting Surface*—A flat surface consisting of a piece of $\frac{3}{4}$ -in. (19-mm) thick exterior- grade plywood with the “A” surface upward to support the test carpet and pad. ~~The~~ If necessary, the four corners (only) of the test carpet and pad may be fastened to the supporting surface, but only the four corners, surface by any acceptable means.

5.12 *Rotating Agitator Reference Vacuum Cleaner*, one, for calibrating test carpets (see ~~10.49.3~~).

5.13 *Straight-Air Canister Reference Vacuum Cleaner*, one, for calibrating test carpets (see ~~10.49.3~~).

6. Materials

6.1 Standard carpets conforming to Specification F 655,

6.2 Standard carpet padding conforming to Specification F 655,

6.3 Test dirt (see Annex A1),

6.3.1 Silica sand (see Annex A1), and

³ Annual Book of ASTM Standards, Vol 14.02.

³ The sole source of supply of the apparatus (OHAUS Models GT-8000, LB30-CO and 1119D) known to the committee at this time is OHAUS, Inc., Florham Park, NJ. (It is recommended that the scale read directly in grams.) If you are aware of alternative suppliers, please provide this information to ASTM International Headquarters. Your comments will receive careful consideration at a meeting of the responsible technical committee, which you may attend.

⁴ Annual Book of ASTM Standards, Vol 15.08.

⁴ The Mettler-Toledo Model PM 2000, available from Mettler-Toledo, Inc. Box 71, Hightstown, NJ 08520, the OHAUS Model GT-8000 available from OHAUS, Inc. Florham Park, NJ, or equivalent, have been found suitable for this purpose. (It is recommended that the scale read directly in grams.) If you are aware of alternative suppliers, please provide this information to ASTM International Headquarters. Your comments will receive careful consideration at a meeting of the responsible technical committee, which you may attend.

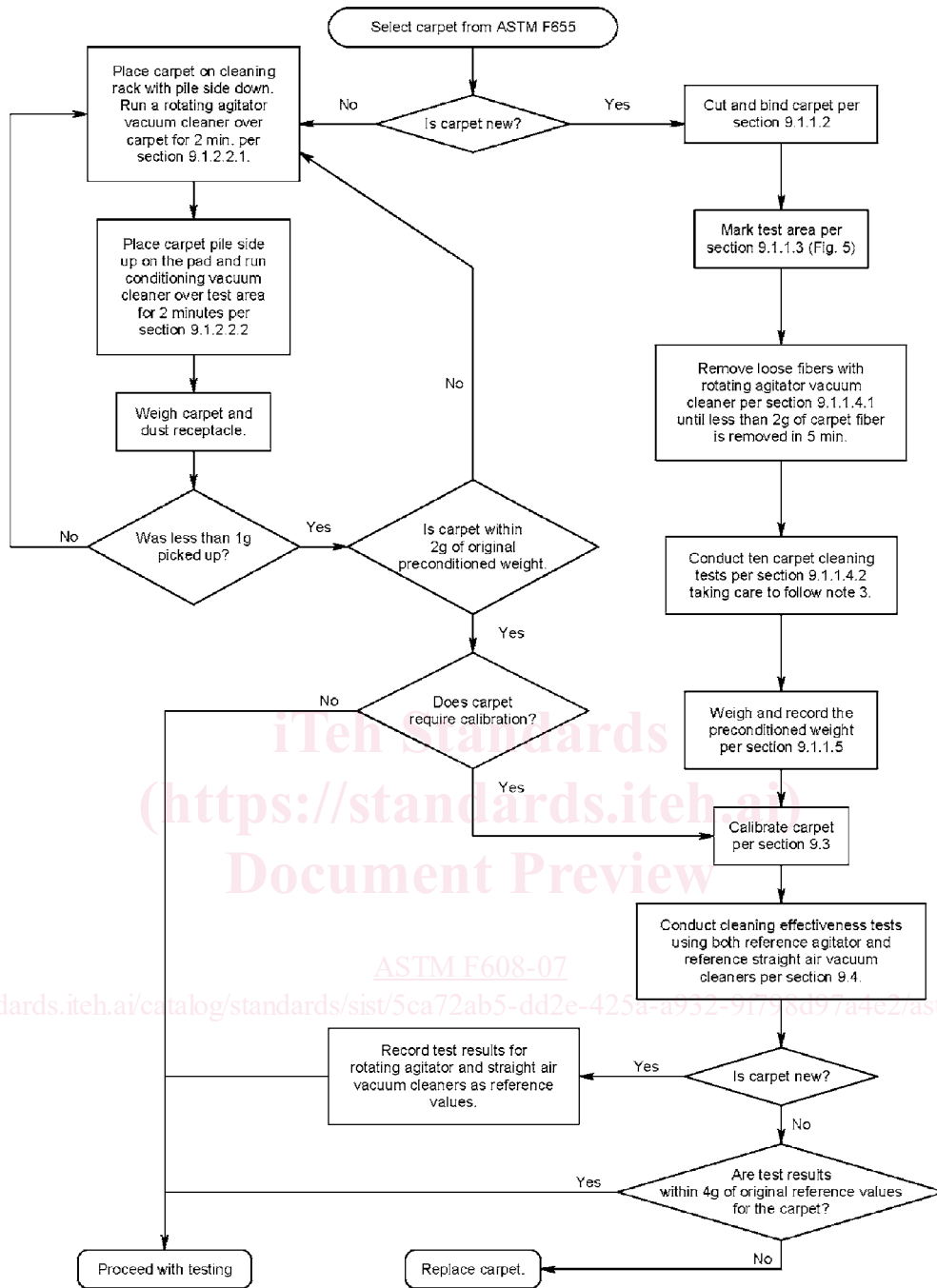

FIG. 1 Carpet Conditioning/Calibration Procedure

6.3.2 Talc (see Annex A1).

7. Sampling

7.1 A minimum of three units of the same model vacuum cleaner selected at random in accordance with good statistical practice, shall constitute the population sample.

7.1.1 To determine the best estimate of cleaning ability effectiveness for the population of the vacuum cleaner model being tested, the arithmetic mean of the cleaning ability rating of the sample from the population shall be established by testing it to a 90 % confidence level within $\pm 5\%$ of the mean value of the cleaning ability rating.

7.1.2 Annex A3 provides a procedural example for determining the 90 % confidence level and when the sample size shall be increased.

NOTE 2—See Annex A3 for method of determining 90 % confidence level.

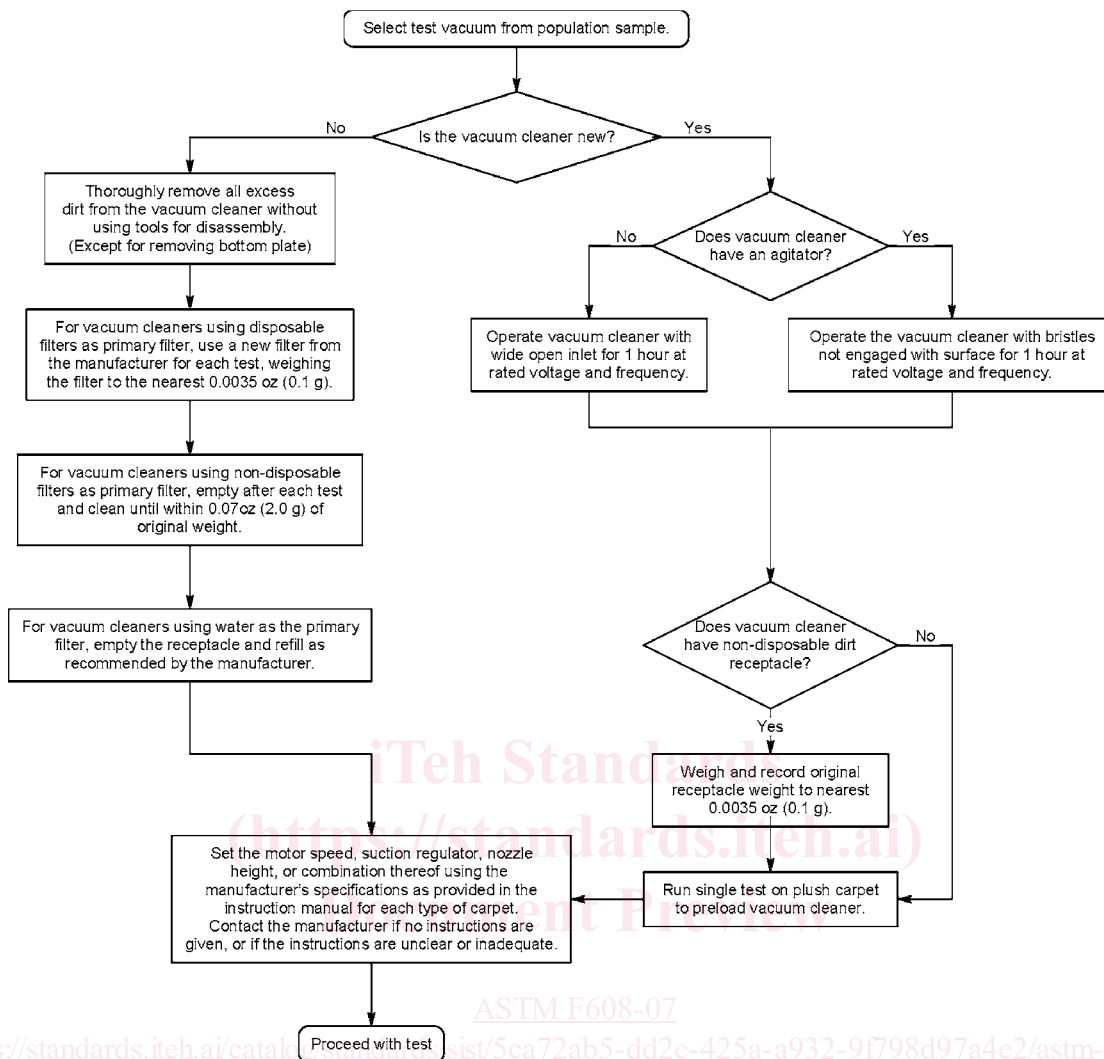

FIG. 2 Vacuum Cleaner Conditioning Procedure

8. Conditioning

8.1 *Test Room*—Maintain the test room in which all conditioning and vacuum cleaner testing is performed at $70 \pm 5^\circ\text{F}$ ($21 \pm 3^\circ\text{C}$) and 45 to 55 % relative humidity.

8.2 All components involved in the test shall remain and be exposed in the controlled environment for at least 16 h prior to the start of the test.

9. Test Carpets

9.1 New test carpets shall conform to Specification F655 Procedure

9.1 *Test Carpet Preparation:*

9.1.1 *Preconditioning New Test Carpet Samples:*

9.1.1.1 New test carpets shall conform to Specification F 655.

9.1.1.2 Cut a sample of each test carpet to a size of 27 by 72 in. (690 by 1830 mm) minimum. If the warp direction or “lay” of the carpet can be determined, it shall be in the 72 in. direction as indicated in Fig. 35. Carpets shall be bound on all sides.

9.1.2.1.3 Mark the test area on each carpet as indicated in Fig. 35.

9.1.3 *Precondition new test carpet samples:* 9.1.1.4 *Precondition New Test Carpet Samples:*

9.1.3.1 *Precondition*

(1) *Precondition* the entire area of the carpet by cleaning with the rotating agitator conditioning vacuum cleaner. Continue the operation until less than 2 g of carpet fiber is picked up in 5 min.

9.1.3.2 *Run* (2) *Run* ten carpet-embedded dirt removal effectiveness test runs in accordance with Section 12 before conducting test calibrations in accordance with Section 11.9.4.2-9.4.18.

9.1.4

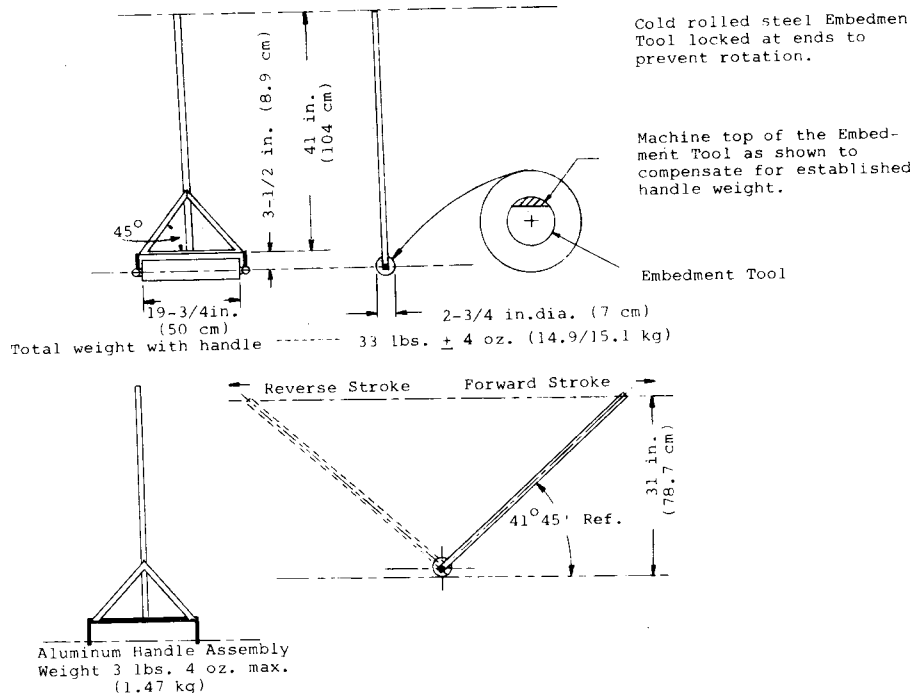

FIG. 3 Dirt Embedment Tool

NOTE 3—Recondition the new test carpet following each preconditioning test run. It is not necessary, however, to meet the requirements set forth in 9.1.2.1 with respect to the preconditioned weight.

9.1.1.5 Weigh and record the preconditioned weight of the carpet.

9.1.5 Run 9.1.1.6 Run a test carpet calibration in accordance with Section 11.9.3.

9-2

9.1.2 Reconditioning Used Test Carpet Samples:

9.2.1

9.1.2.1 To remove the residual dirt and stabilize the moisture content, clean the carpet with a rotating agitator conditioning vacuum cleaner until its weight does not exceed its previously measured, original preconditioned weight (9.1.4) by more than 2 g and less than 1 g is picked up by the conditioning vacuum cleaner after 4 min of cleaning.

9.2.2.9.1.1.5 by more than 0.07 oz (2 g) or less than 0.035 oz (1 g) is picked up by the conditioning vacuum cleaner using the following procedure.

9.1.2.2 Procedure:

9.2.2.1 Clean the test carpet with the rotating agitator conditioning vacuum cleaner at a rate of 1.8 ft/s (0.55 m/s) as follows:

9.2.2.2(1) Place the carpet on the carpet cleaning rack (Fig. 24) with the pile side down. Run the rotating agitator conditioning vacuum cleaner over the carpet for 2 min concentrating on the test area at 1.8 ft/s (0.55 m/s); then run the rotating agitator conditioning vacuum cleaner thoroughly over the entire carpet area at least one time.

9.2.2.3 Then place (2) Place the carpet (nap (pile side up) on the pad, on the plywood supporting surface, and clean it with the rotating agitator conditioning vacuum cleaner for 2 min, concentrating on the test area; then run the rotating agitator vacuum cleaner thoroughly over the entire area at least one time.

9.2.2.4 Weigh (3) Weigh the carpet.

9.2.2.5 Keep (4) Keep alternating 9.2.2.2.9.1.2.2(1) and 9.2.2.3.9.1.2.2 (2), always ending with the pile side up, until the carpet weight meets the requirements of 9.1.2.1.

9.2.2.6 A high-cleaning performance rotating agitator vacuum cleaner is recommended for reducing the time to recondition the carpet.

9.2.2.7 Change the disposable primary filter after a maximum of every four runs on the conditioning vacuum cleaner or more often if required:

9-3

(5) Change the disposable primary filter after a maximum of every 4 runs on the conditioning vacuum cleaner or more often if required.

NOTE 4—A high-cleaning performance rotating agitator vacuum cleaner is recommended for reducing the time to recondition the carpet.

9.1.3 Reconditioning Used Carpet Padding:

9.1.3.1 Clean the carpet padding by shaking after each day's testing weekly or more often, if necessary, to remove any collected dirt.

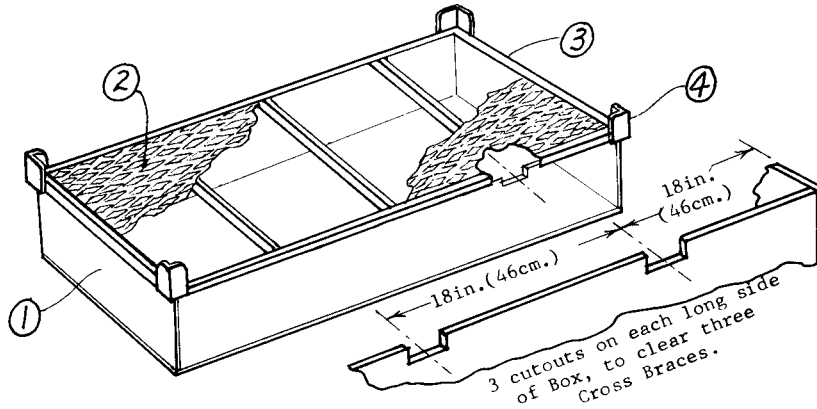

- ① -- Five Sided Box with open top.
 Outside Dimensions, Length -- 72 in. (183 cm.)
 Width -- 27 in. (69 cm.)
 Depth -- 12 in. (30.5 cm.)
 Material -- Plywood, 3/4 in. (1.9 cm.) thick.
 Optional -- Bottom of box may be sloped downward to center opening to simplify emptying of test dirt accumulation.
- ② -- Flattened Expanded Steel Top Panel, .070 in. (1.8 mm) thick, with "75% open" area, and with diamond shaped openings:--
 center-to-center, 2.1 in. (5.3 cm.) LWD
 center-to-center, 0.93 in. (2.4 cm.) SWD
 opening dimensions, 1.78 in. (4.5 cm.) LWD
 opening dimensions, 0.688 in. (1.7 cm.) SWD
 NOTE: Demcor Style "3/4 in.-#13" material has been found to be acceptable. (Designer's Metal Div'n. of Southern Electric, Inc.)

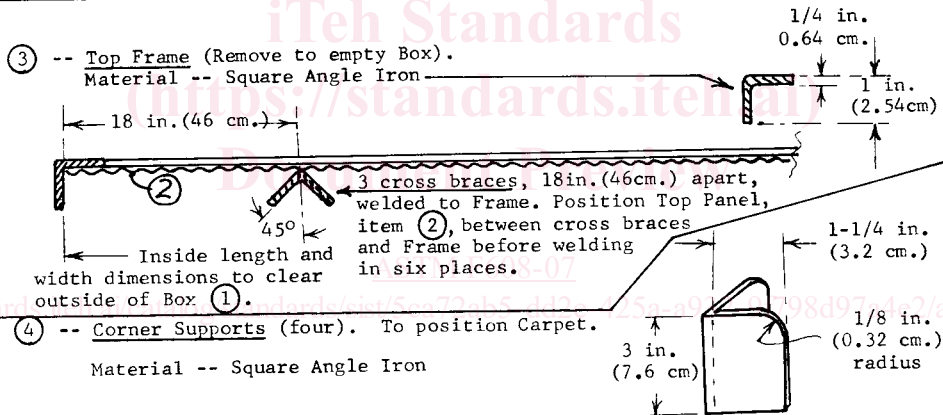
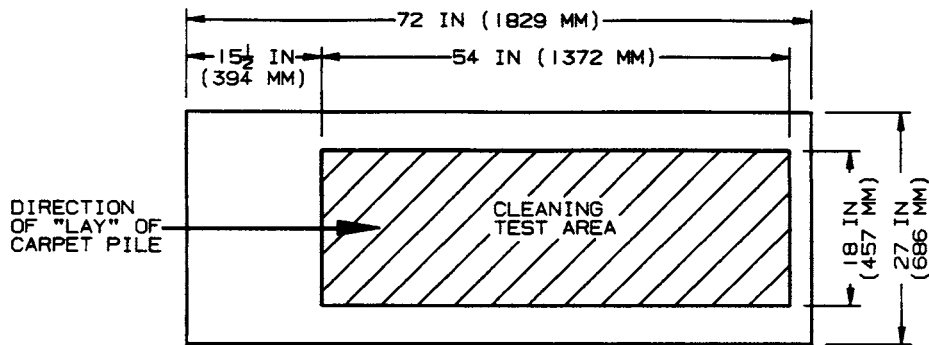

FIG. 4 Carpet Cleaning Rack



NOTE—Cleaning test area should be positioned as shown. First forward stroke of cleaner is in direction with "lay" of carpet.

FIG. 5 Test Carpet

9.1.3.2 Replace the carpet padding when it has holes, tears, or other signs of wear. †0-

9.2 Preparation of Test Vacuum Cleaners:

~~10.1~~

9.2.1 New Test Vacuum Cleaners:

~~10.1.1~~ Preconditioning a New Test Vacuum Cleaner—Run

9.2.1.1 Run the vacuum cleaner in at rated voltage $\pm 1\%$ and rated frequency with filters in place.

~~10.1.1.1~~ (1) Preconditioning a Rotating Agitator Type Vacuum Cleaner—In a stationary position, operate the vacuum cleaner for 1 h with the agitator bristles not engaged on any surface.

~~10.1.1.2~~ (2) Preconditioning a Straight-Air Canister Type Vacuum Cleaner—Operate the vacuum cleaner for 1 h with a wide-open inlet (without hose).

~~10.1.2~~ For 9.2.1.2 For vacuum cleaners with non-disposable dirt receptacles, weigh and record the receptacle's original weight to the nearest 0.0035 oz (0.10 g).

~~10.2~~ 9.2.2 Used Test Vacuum Cleaners:

~~10.2.1~~ Recondition

9.2.2.1 Recondition a used test vacuum cleaner, prior to each test run, as follows:

~~10.2.1.1~~ Thoroughly (1) Thoroughly remove excess dirt from the vacuum cleaner. Without using tools for disassembly, clean the entire outer surface, brushes, nozzle chamber, ductwork, inside of the chamber surrounding the primary filter, and inside hose and wands. Check the condition of all mechanisms for signs of wear or damage.

~~10.2.1.2~~ (2) For vacuum cleaners using disposable filters as the primary filters, use a new disposable primary filter from the manufacturer for each test run. Weigh the filter to the nearest 0.0035 oz (0.10 g) and install it as recommended by the vacuum cleaner manufacturer.

~~10.2.1.3~~ For (3) For vacuum cleaners using water as the primary filter, empty the receptacle and refill as recommended by the manufacturer.

~~10.2.1.4~~ (4) For vacuum cleaners using non-disposable dirt receptacles, empty in accordance with the manufacturer's instructions after each test run and clean the receptacle until its weight is within 0.07 oz (2 g) of its original weight. Weigh the receptacle to the nearest 0.0035 oz (0.10 g) and install it as recommended by the vacuum cleaner manufacturer.

NOTE 5—It is recommended that a replaceable brush drive belt for vacuum cleaner agitators be changed after each four test runs, if considered applicable, using manufacturer's instructions. Any other maintenance task, such as cleaning the brush belt with distilled water, should only be done in accordance with manufacturer's recommendations.

~~10.3~~ 9.2.3 Test Vacuum Cleaner Settings—If:

9.2.3.1 If various settings are provided, set the motor speed setting, suction regulator, nozzle height, or combination thereof using the manufacturer's specifications as provided in the instruction manual for each type of carpet. Contact the manufacturer if no instructions are given, or if the instructions are unclear or inadequate.

~~10.3.1~~ 9.2.3.2 All straight line movement (see Test Method F 1409), sound power (see Test Method F 1334), and motor life evaluation (see Specification F 655 and Test Methods F 884, F 922, F 1038, F 884, F 922, and F 1038) tests shall be conducted using the same settings (nozzle, motor speed, suction regulator, etc.) for each specific carpet.

~~10.4~~

9.2.4 Reference Vacuum Cleaners (Calibration) :

~~10.4.1~~ Use

9.2.4.1 Use the reference vacuum cleaners only for determining the reference rating of carpets and for the verification of carpet acceptability (see ~~Section 11.3~~).

~~10.4.2~~ Maintain 9.2.4.2 Maintain the performance of the reference vacuum cleaners throughout the acceptable life of the carpet.

11. Carpet (i.e. nozzle suction, bristle extension, motor and agitator speeds, etc.).

9.3 Test Carpet Calibration:

~~11.1~~ The

9.3.1 The purpose of calibration is to determine when the test carpet needs to be replaced by establishing a reference rating for each new preconditioned test carpet and to check this rating every 50 or fewer test runs.

~~11.2~~ The 9.3.2 The reference ratings are determined for each test carpet by the percent pickup using the reference rotating agitator vacuum cleaner and the reference straight-air vacuum cleaner.

~~11.3~~ This 9.3.3 The percent pickup is determined by performing a carpet-embedded dirt removal effectiveness test (see ~~Section 12.4~~).

~~11.4~~ Repeat the test carpet calibration procedure on the carpets every 50 or fewer test runs.

~~11.5~~ When the embedded dirt rating for either reference cleaner varies by 4 g from the original reference rating for the carpet, replace the carpet.

12. Carpet-Embedded Dirt Removal Effectiveness Test

12.1 Prepare test carpets in accordance with 9.1 for new carpets or 9.2 for used carpets.

12.2 Perform a calibration test, if required, in accordance with Section 11.

12.3 If preconditioning or reconditioning has been done more than 1 h before a test run, weigh the carpet. If the weight of the

carpet exceeds the preconditioned or reconditioned weight by more than 2 g, clean the carpet with a rotating agitator conditioning vacuum cleaner until this criteria is met:

12.4 Position the test carpet on the padding (with “scrim” side of the padding up) on the supporting surface (see 9.3.4). When the embedded dirt rating for either reference cleaner varies by 0.14 oz (4 g) from the original reference rating for the carpet, replace the carpet.

NOTE 6—Carpet pick up changes over time as the test carpet panel is used due to normal carpet wear. General laboratory practice is to track and record the number of test runs on each carpet panel. It is recommended to estimate, as closely as possible, the number of required test runs on all carpet panels intended to be used prior to starting any test program in order to establish that the selected carpet panels have a sufficient number of test runs left to complete the test program. All products being tested in a comparison test must be tested on the same calibrated carpet panel throughout the test program. If a particular carpet panel is found to no longer be acceptable for testing due to the 0.14 oz (4 g) limit being exceeded during a calibration check, all products tested on that particular carpet panel during the test program must be retested on the new carpet panel to insure proper comparison.

9.4 Carpet Embedded Dirt Removal Effectiveness Test:

9.4.1 If preconditioning or reconditioning has been done more than 1 h before a test run, weigh the carpet. If the weight of the carpet exceeds the preconditioned or reconditioned weight by more than 0.07 oz (2 g), clean the carpet with a rotating agitator conditioning vacuum cleaner until these criteria are met.

9.4.2 Position the test carpet on the padding (with “scrim” side of the padding up) on the supporting surface (see 5.11).

12.5 Prepare test cleaners and dirt receptacles in accordance with Section 10

9.4.3 The test cleaners and dirt receptacles should be prepared in accordance with 9.2.

12.5.1 Weigh 9.4.4 Weigh the prepared dirt receptacle (that is, dust bag or other primary filter device) prior to conducting the measurement test run. Record the weight to the nearest 0.0035 oz (0.10 g).

12.5.2 Install 9.4.5 Install the primary filter as explained below:

12.5.2.1 For 9.4.5.1 For vacuum cleaners using disposable or non-disposable primary filters, install the primary filter from the manufacturer per their instructions.

12.5.2.2 For 9.4.5.2 For vacuum cleaners using water as the primary filter, empty and refill the receptacle as recommended by the vacuum cleaner manufacturer.

12.5.2.3 For vacuum cleaners using non-disposable primary dirt receptacles, clean the receptacle in accordance with 10.2.1.4 and install it per the manufacturer’s instructions.

12.5.3 Ensure 9.4.6 Ensure that the vacuum cleaner settings have been made in accordance with 10.39.2.3.

12.6

9.4.7 Test Dirt Preparation—Weigh and mix 3.17 ± 0.0035 oz (90 ± 0.1 g) of silica sand and 0.35 ± 0.0035 oz (10 ± 0.1 g) of commercial grade talcum, both conforming to the specifications found in Annex A1. Note 3—Operator should view the Material Safety Data Sheets (MSDS) on both talc and silica sand before performing this test.

12.6.1 Silica sand shall be sieved to assure conformance to the specification of

9.4.7.1 Silica sand shall be sieved to assure conformance to the specification of A1.2. Sieving shall be performed in accordance with Test Method Practice D 75.

12.6.2 Bulk 9.4.7.2 Bulk mixing and storage of sieved constituents of silica sand is acceptable if assay analysis meets the specification of A1.2.

12.6.3 Bulk 9.4.7.3 Bulk storage of test dirt mixture (sand plus talc) is not allowed.

12.7 Distribute 9.4.8 Distribute 3.52 oz (100 g) of the test dirt uniformly on the cleaning test area (see Fig. 35), using any convenient spreading method.

12.8 Embed the test dirt into the carpet using the dirt embedment tool shown in Fig. 1. Perform the embedding process by using a dragging motion in both directions with the handle held at the angle shown. Drag the dirt embedment tool over the test area exactly 30 strokes, alternating directions forward and back. (A movement in one direction is one “stroke.”) Use a uniform movement to provide a “stroke” time of 2.5 s (a rate of 1.8 ft/s (0.55 m/s)). The first forward stroke shall be in the direction of carpet lay.

12.8.1 An acceptable laboratory practice shall be used to ensure that the dirt embedment tool shall not fall short of reaching the end boundaries of the test area, and the tool shall cover both side boundaries of the test area at all times.

12.9 Clean the embedding tool thoroughly.

12.10 Energize the cleaner for 2 min at nameplate rated voltage ($\pm 1\%$) and frequency (± 1 Hz) immediately preceding the test sequence of 12.11. For vacuum cleaners with dual nameplate voltage ratings, conduct testing at the highest voltage.

12.10.1 For a rotating agitator-type vacuum cleaner, place it such that the bristles clear the supporting surface and no loose dirt is picked up.

12.10.2 For a straight-air canister vacuum cleaner, operate with the rug tool unrestricted, positioned such that no loose dirt is picked up from the supporting surface.

12.11 Immediately following the 2-min “run-in” of 12.10, deenergize the vacuum cleaner and place the vacuum cleaner nozzle on the test carpet so that the front edge of the vacuum cleaner coincides with the line defining the beginning of the test area and the right side of the boundary of the 18-in. test width (see Fig. 4). The forward stroke of the nozzle shall be in the direction of the carpet lay (see

9.4.9 Embed the test dirt into the carpet using the dirt embedment tool shown in Fig. 3. Perform the embedding process by using a dragging motion in both directions with the handle held at the angle shown. Drag the dirt embedment tool over the test area exactly 30 strokes, alternating directions forward and back. (A movement in one direction is one “stroke.”) Use a uniform movement to provide a “stroke” time of 2.5 s (a rate of 1.8 ft/s (0.55 m/s)). The first forward stroke shall be in the direction of the carpet lay.

NOTE 7—An acceptable laboratory practice shall be used to ensure that the embedment tool shall not fall short of reaching the end boundaries of the test area, and the tool shall cover both side boundaries of the test area at all times.

9.4.10 Clean the embedding tool as needed.

9.4.11 If the vacuum cleaner has not been energized for more than 60 min, energize the cleaner for 2 min at nameplate rated voltage ($\pm 1\%$) and frequency (± 1 Hz) immediately preceding the test sequence of 9.4.12. For vacuum cleaners with dual nameplate voltage ratings, conduct testing at the highest voltage.

9.4.11.1 For a rotating agitator-type vacuum cleaner, place it such that the bristles clear the supporting surface and no loose dirt is picked up.

9.4.11.2 For a straight-air canister vacuum cleaner, operate with the rug tool unrestricted, positioned such that no loose dirt is picked up from the supporting surface.

9.4.12 Immediately following the 2-min “run-in” of 9.4.11, deenergize the vacuum cleaner and place the vacuum cleaner nozzle on the test carpet so that the front edge of the vacuum cleaner coincides with the line defining the beginning of the test area and the right side of the boundary of the 18-in. test width (see Fig. 6). The forward stroke of the nozzle shall be in the direction of the carpet lay (see Fig. 5).

9.4.12.1 Reasonable efforts shall be made to maintain the handle height at 31.5 in. (0.8 m) during each test run for vacuum cleaners with a pivoting handle.

9.4.12.2 Reasonable efforts shall be made to maintain the vacuum cleaner’s nozzle parallel to the test carpet surface during each test run for vacuum cleaners with non-pivoting handles.

9.4.13 Tilt or lift the nozzle off the carpet, energize the vacuum cleaner, and adjust the voltage to rated voltage $\pm 1\%$. Allow the vacuum cleaner to run and expand the filter bag, if one is present.

9.4.14 Test Cleaning Pattern:

9.4.14.1

9.4.14.1 For a rotating agitator-type vacuum cleaner, lower the nozzle onto the carpet before the test area. Again, adjust the voltage to rated voltage $\pm 1\%$; then move the nozzle at a rate of 1.8 ft/s (0.55 m/s) in the test cleaning pattern and motion as specified in Annex A2 during the cleaning cycle. Maintain the nozzle position and settings as specified in 9.4.14.3 during the cleaning cycle.

9.4.14.2 For a straight-air vacuum cleaner, position the nozzle on the carpet before the test area. Again, adjust the voltage to rated voltage $\pm 1\%$; then move the nozzle at a rate of 1.8 ft/s (0.55 m/s) in the test cleaning pattern and motion as described in Annex A2. Maintain the nozzle position and settings as specified in 9.4.14.3 during the cleaning cycle.

9.4.14.3 At the end of the last stroke, smoothly tilt or lift the vacuum cleaner nozzle off the carpet and allow the vacuum cleaner to run approximately an additional 10 s to clear the system of test dirt actually picked up but temporarily trapped in it. Then deenergize within it before de-energizing the vacuum cleaner. During the additional run period, the hose used with the canister and combination vacuum cleaners should be flexed to help clear the system.

9.4.15 For vacuum cleaners with removable dirt receptacles, carefully remove the dust receptacle (that is, dust bag or other primary filter device) and weigh it. Record the weight to the nearest 0.10 g (0.0035 oz).

9.4.15.1 For bagless dirt receptacles, remove the dirt receptacle assembly, including whatever filters it contains.

9.4.16 For vacuum cleaners using water as the primary filter, weigh the carpet to the nearest 1.0 g (0.035 oz) (1.0 g).

9.4.17 Determination of the grams picked up for each test run will be done in the following manner:

9.4.15.1 For vacuum cleaners with removable dirt receptacles, subtract the weight of the clean dirt receptacle at the start of the

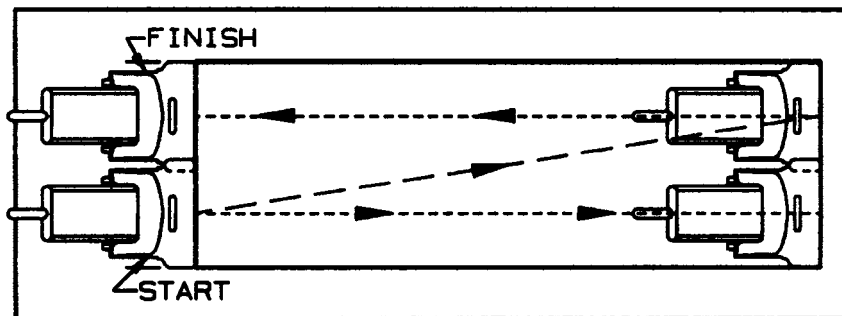

NOTE—This shows the nozzle positions for the cleaning pattern when $N = 2$. (Refer to Annex A2.)

FIG. 6 Cleaner Nozzle Position at Start and Finish of Test Cleaning Strokes

test from the weight of the dirt receptacle at the end of the test. Record results to the nearest 0.10 g (0.0035 oz).

12.15.2 For vacuum cleaners using water as the primary filter, add 100 g (3.53 oz) to the weight of the carpet at the start of the test run and subtract the weight of the carpet at the end of the test run. Record results to the nearest 1.0 g (0.035 oz).

12.16 The percent carpet-embedded dirt removal effectiveness for a single test run of a given vacuum cleaner on a given carpet is the grams recorded in 12.15 divided by the 100 g, multiplied by 100.

12.17 Using the same test vacuum cleaner, repeat 12.1-12.16

9.4.17.1 For vacuum cleaners with removable dirt receptacles, subtract the weight of the clean dirt receptacle at the start of test from the weight of the dirt receptacle at the end of the test. Record results to the nearest 0.0035 oz (0.10 g).

9.4.17.2 For vacuum cleaners using constructions or technologies for which weighing a dirt receptacle, filter(s) or filter bag is impractical or does not provide reliable results, add 3.53 oz (100 g) to the weight of the carpet at the start of the test run and subtract the weight of the carpet at the end of the test run. Record results to the nearest 0.035 oz (1 g).

NOTE 8—If it is necessary to use the procedure in 9.4.17.2 for one vacuum cleaner in a comparison test, the same method must be used for all vacuum cleaners in the comparison.

9.4.18 The percent carpet-embedded dirt removal effectiveness for a single test run of a given vacuum cleaner on a given carpet is the grams recorded in 9.4.17 expressed as a percentage.

9.4.19 Using the same test vacuum cleaner, repeat 9.4.1-9.4.18 two additional times for a total of three test runs.

12.18 The percent carpet-embedded dirt removal effectiveness for each individual test vacuum cleaner from the population sample is the average of three test runs meeting the repeatability statement in Section 13. See Annex A3

NOTE 9—If after the first three tests on a *new vacuum cleaner sample*, the repeatability limits are not met due to the results of the first test run, the first test run may be discarded and replaced with an additional test run.

9.4.20 The percent carpet-embedded dirt removal effectiveness for each individual test vacuum cleaner from the population sample for a given carpet is the average of three test runs meeting the repeatability statement in Section 11. See A3.3 for a procedural example and whether further test runs need to be conducted.

12.19 A minimum of two additional test sample units of the same model shall be selected in accordance with the sampling statement of Section

9.4.21 The percent carpet-embedded dirt removal effectiveness for each individual vacuum cleaner from the population sample is the geometric mean of the individual carpet values. See Annex A3 for a procedural example on calculating the geometric mean.

9.4.22 A minimum of two additional test sample units of the same model shall be selected in accordance with the sampling statement of Section 7. Repeat 12.1-12.18. Repeat 9.4.1-9.4.20 for each new test sample unit selected.

12.20 The 9.4.23 The percent carpet-embedded dirt removal effectiveness for the population of the vacuum cleaner model being tested is the arithmetic mean of geometric mean values of the percent carpet-embedded dirt removal effectiveness from a sample of the population meeting the requirements of the sampling statement (Section 7).

13. Precision and Bias

13.1 The following precision statements are based on interlaboratory tests involving six laboratories and two test units (one upright vacuum cleaner with agitator and one canister with straight-air floor tool):

13.2 The statistics have been calculated as recommended in Practice E 691

10. Report

10.1 For each vacuum cleaner sample from the population being tested, report the following information:

10.1.1 Manufacturer's name, product name, product model, and serial number.

10.1.2 Type of cleaner; that is, upright, canister, etc.

10.1.3 The average soil removed for each of the standard carpets specified in Specification F 655 tested.

10.1.4 The geometric mean of the soil removal from all carpets specified in Specification F 655 carpets.

10.2 The overall average(s), standard deviation(s), and 90 % confidence results for all of the population sample tested shall also be reported.

11. Precision and Bias ⁵

11.1 The following precision statements are based on interlaboratory tests involving six laboratories and two test units (one upright vacuum cleaner with agitator and one canister with straight-air floor tool).

11.2 The statistics have been calculated as recommended in Practice E 691.

13.3 The 11.3 The following statements regarding repeatability limit and reproducibility limit are used as directed in Practice E 177.

⁵ The OHAUS Models GT-8000, LB30-CO and 1119D all available from OHAUS, Inc., Florham Park, NJ or equivalent, have been found suitable for this purpose. It is recommended that the scale read directly in grams.

⁵ Supporting data have been filed at ASTM International Headquarters and may be obtained by requesting Research Report F11-1010.