



Designation: D2687 – 95(Reapproved 2007)^{ε1}

Standard Practices for Sampling Particulate Ion-Exchange Materials¹

This standard is issued under the fixed designation D2687; the number immediately following the designation indicates the year of original adoption or, in the case of revision, the year of last revision. A number in parentheses indicates the year of last reapproval. A superscript epsilon (ϵ) indicates an editorial change since the last revision or reapproval.

^{ε1} NOTE—Warning notes were moved into the standard text editorially in January 2008.

1. Scope

1.1 These practices² cover procedures for obtaining representative samples of ion-exchange materials. The following practices are included:

	Sections
Practice A—Sampling from a Single Package and Multiple Package Lots or Shipments	4 to 11
Practice B—Sampling from Fixed Bed Ion-Exchange Equipment Having Unrestricted Head Room	12 to 16
Practice C—Sampling from Fixed Bed Ion-Exchange Equipment Having Restricted Head Room	17 to 21

1.2 *This standard does not purport to address all of the safety concerns, if any, associated with its use. It is the responsibility of the user of this standard to establish appropriate safety and health practices and determine the applicability of regulatory limitations prior to use.*

2. Referenced Documents

2.1 *ASTM Standards:*³

C183 Practice for Sampling and the Amount of Testing of Hydraulic Cement

D1129 Terminology Relating to Water

3. Terminology

3.1 *Definitions*—Certain terms in these practices that relate to ion exchange are defined in Terminology **D1129**.

PRACTICE A—SAMPLING FROM A SINGLE PACKAGE AND MULTIPLE PACKAGE LOTS OR SHIPMENTS

4. Summary of Practice

4.1 A hollow, sample-probe guide that is comprised of mating threaded sections and that can be extended to any

¹ These practices are under the jurisdiction of ASTM Committee **D19** on Water and are the direct responsibility of Subcommittee **D19.08** on Membranes and Ion Exchange Materials.

Current edition approved Dec. 1, 2007. Published January 2008. Originally approved in 1968. Last previous edition approved in 2001 as D2687 – 95 (2001). DOI: 10.1520/D2687-95R07E01.

² These practices were developed from activities within ASTM Committee **D19**.

³ For referenced ASTM standards, visit the ASTM website, www.astm.org, or contact ASTM Customer Service at service@astm.org. For *Annual Book of ASTM Standards* volume information, refer to the standard's Document Summary page on the ASTM website.

convenient length by the addition of more sections, is inserted into an ion-exchange unit. A sampling tube is inserted through the probe guide and is connected to a vacuum source. Ion-exchange material is removed by eduction. A core sampler also may be used.

5. Significance and Use

5.1 This practice will be used most frequently to sample materials as received from the manufacturer in the original shipping container and prior to any resin-conditioning procedure. Since certain ion-exchange materials are supplied by the manufacturer in the dry or free-flowing state whereas others are supplied moist, it is necessary to employ two different sampling devices. Therefore, this practice is divided into Sampling Procedure—Dry or Free-Flowing Material (Section 8), and Sampling Procedure—Moist Material (Section 9).

5.2 Once the sample is obtained, it is necessary to protect the ion-exchange materials from changes. Samples should be placed in sealable, gasproof containers immediately.

6. Apparatus

6.1 *Sampling Devices*, as shown in **Fig. 1** and **Fig. 2**.

NOTE 1—The sampling device described in **Fig. 2** is the same as that used in Practice **C183**.

6.2 *Sealable, Gasproof Containers*, for sample storage.

6.3 *Sample Quartering Materials*—A 0.5 by 0.5 m (20 by 20 in.) sheet of glazed paper, oil cloth, or flexible plastic film.

7. Kind and Number of Samples

7.1 For a representative sample from a single package, a minimum of three probes or increments should be taken with the sampling device.

7.2 For a representative sample from a multiple package lot or shipment:

7.2.1 If the markings on the package indicate the material to be sampled is from a single lot (batch or manufacturing run), the number of packages selected shall be not less than 10 % of the packages received. When less than 30 packages are received, a minimum of three packages shall be chosen at random for sampling. If a single lot contains more than 30

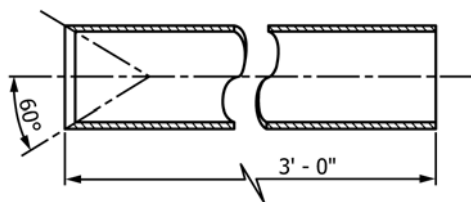

FIG. 1 51-mm (2-in.) Inside Diameter Plastic Tube with 2.4-mm (3/32-in.) Wall Thickness Ion-Exchanger Sampling Tube



NOTE 1—This device shall be between 1.2 and 1.5 m (4 and 5 ft) long and about 35 mm (1 3/8 in.) in outside diameter. It shall consist of two polished brass telescopic tubes with registering slots which are opened or closed by rotation of the inner tube, the outer tube being provided with a point to facilitate penetration

FIG. 2 Slotted Tube Sample for Ion-Exchange Resins

packages and the order of filling is designated on the packages, the first, last, and middle packages shall be sampled. If the results of the analysis of these three samples agree within the limits of precision of the test methods used, further samples from the lot need not be taken. If they are not in agreement, additional samples may be taken at the option of the parties concerned. When the entire shipment or an entire lot consists of three packages or less, a sample shall be taken from each package. The number of samples taken with the sampling device should not be less than three per individual package.

7.2.2 If the shipment consists of more than one lot (batch or manufacturing run) of material, sample each lot separately as in 7.2.1. For a representative sample of the entire shipment, the number of packages sampled per lot should be in the same ratio as the number of packages of that lot in the entire shipment. For example, if the shipment consists of 40 drums of lot *x* and 60 drums of lot *y*, sample four drums of lot *x* and six drums of lot *y*.

8. Sampling Procedure—Dry or Free-Flowing Material

8.1 If the ion-exchange material is dry or free-flowing and contained in a drum:

8.1.1 Rock the drum slightly from several sides for uniform packing and open.

8.1.2 The points chosen for probing on the surface should lie on a circle approximately two thirds the diameter of the drum and uniformly spaced.

8.1.3 Rotate the inner tube of the sampling device (Fig. 2) to the closed position, and thrust the sampling device to the bottom of the drum.

8.1.4 Rotate the inner tube to the open position and collect the sample by moving the top of the sampling device in a circle (about 75 to 150 mm (3 to 6 in.) in diameter) several times with the open sections forward.

8.1.5 Rotate the inner tube to the closed position and remove the sampling device from the drum.

NOTE 2—The sharp point of the sampling device may pierce the drum liner. Have the point rounded slightly (by grinding, filing, etc.).

NOTE 3—Corrosion may occur after only a few months on this type of sampling device and will render it unsuitable for resin sampling.

8.1.6 Empty the contents into the sample container.

8.1.7 Repeat 8.1.3 through 8.1.6 until sufficient sample is obtained. A minimum of three probes or increments is required. If the sample obtained is larger than required, reduce the sample using the quartering techniques given in 10.1.

8.1.8 Seal the sample container and affix label as outlined in Section 11.

8.1.9 Alternatively, the sampling tube (Fig. 1) may be used for sampling dry or free-flowing resin. Follow procedure given in Section 9. Loss of resin from the bottom of the sampler may occur and cause bias in the sample.

8.2 If the ion-exchange material is dry or free-flowing and the outer package is a bag:

8.2.1 Transfer the contents of the bag to a drum which has a diameter less than its height and will hold the entire contents of the bag.

8.2.2 Proceed in accordance with 8.1.

NOTE 4—The sampling device (Fig. 2) can allow resin entering the upper openings to fall into the bottom portion of the device, thereby biasing the sample.

9. Sampling Procedure—Moist Material

9.1 If the ion-exchange material is moist and contained in a drum:

9.1.1 Upend the drum and allow to stand 16 h (overnight) to redistribute any excess water that may be present.

9.1.2 Right drum, rock it slightly from several sides for uniform packing and open.

9.1.3 The points chosen for probing on the surface should lie on a circle approximately two thirds of the diameter of the drum.

9.1.4 Rapidly thrust the sampling tube (Fig. 1) to the bottom of the drum.

9.1.5 Withdraw the sampling device.

9.1.6 Empty the contents into the sample container.

9.1.7 Repeat 9.1.4 through 9.1.6 until sufficient sample is obtained. A minimum of three probes or increments is required. If the sample obtained is larger than required, reduce the sample using the quartering technique given in 10.1.

9.1.8 Seal the sample container and affix label as outlined in Section 11.

9.2 If the ion-exchange material is moist and the outer package is a bag:

9.2.1 Transfer the contents of the bag to a drum that has a diameter less than its height and will hold the entire contents of the bag.

9.2.2 Proceed in accordance with 9.1.

10. Quartering Procedure

10.1 Using a sheet of glazed paper, oil cloth, or flexible plastic film:

10.1.1 Empty the sample container into the center of the sheet.

10.1.2 Flatten out the sample gently with the palm of the hand until the ion-exchange material is approximately 25 mm (1 in.) thick.

10.1.3 Remix the sample by lifting a corner of the sheet and drawing it across, low down, to the opposite corner in a manner

that the material is made to roll over and over and does not merely slide along. Continue operation with each corner, proceeding in a clockwise direction. Repeat this operation three times.

10.1.4 Lift all four corners of the sheet towards the center and holding all four corners together, raise the entire sheet into the air to form a pocket for the ion-exchange material.

10.1.5 Repeat 10.1.2.

10.1.6 With a straightedge at least as long as the flattened mound of ion-exchange material (such as a thin edged yard stick) gently divide the sample into quarters. An effort should be made to avoid using pressure on the straightedge sufficient to cause damage to particles of ion-exchange material.

10.1.7 Discard alternate quarters.

10.1.8 If further reduction of sample size is necessary, repeat 10.1.3 through 10.1.7. A minimum 1-litre sample is required for complete analysis.

11. Sample Labeling

11.1 Immediately upon placing each sample in its sample container, affix a label, cardboard, or linen tag to the container.

11.2 Note the following information on the label or tag as soon as it becomes available. If this information is too voluminous for inclusion on the label or tag, forward it in a separate letter with appropriate cross reference with the identification on the sample container:

11.2.1 Name of company manufacturing the material.

11.2.2 Manufacturer's product name,

11.2.3 Type of material and ionic form, if known,

11.2.4 Location where material was sampled, including company name and complete address,

11.2.5 Date and time of sampling,

11.2.6 Approximate age of ion-exchange material, if known,

11.2.7 Number of cycles,

11.2.8 Throughput volume, litres per cubic metre (gallons per cubic foot),

11.2.9 Type of service or application,

11.2.10 Reason for sampling, and

11.2.11 Signature and title of sampler.

PRACTICE B—SAMPLING FROM FIXED BED ION-EXCHANGE EQUIPMENT HAVING UNRESTRICTED HEAD ROOM

12. Significance and Use

12.1 The purpose of this practice, "to obtain a representative sample from an ion-exchange unit," implies further testing will be performed on the sample obtained.

12.2 If information as to the operation of a particular ion-exchange unit is desired, sampling of the resin at the end of the regeneration cycle will yield a sample from which more information can be obtained than from an exhausted sample. Analysis of ion-exchange materials in the regenerated form will permit a determination of the efficiency of regeneration under plant conditions, a determination of metallic, organic or siliceous residues which are not removed in normal plant

regeneration, and particularly in the case of mixed bed systems, will detect such problems as insufficient mixing and backwashing.

12.3 This practice will not retrieve ion-exchange material from the bottom 50 mm (2 in.) of a unit without subfill (supporting bed).

12.4 In this practice, the sample is taken in the regenerated form. However, in cases where the sample will be completely reconditioned before analysis, the selection of a point in the operating cycle for sampling is not critical. In this case, the portion of 14.1 and 14.2 relating to conversion of the ion-exchange material to the regenerated form may be omitted.

12.5 The sampling procedure outlined in this practice will be difficult in locations with restricted head room above the ion-exchange unit.

13. Apparatus

13.1 *Sampling Device*, as shown in Fig. 1, Fig. 3, Fig. 6, and Fig. 7.⁴

13.2 *Containers*, sealable, gas-proof, for sample storage.

14. Preparation for Sampling

14.1 For units containing a physical mixture of cation and anion-exchange resin, backwash the bed following exhaustion, regenerate, rinse, and air mix as in normal operating procedures.

14.2 For all other units, backwash the bed following exhaustion, regenerate, and rinse as in normal operating procedure.

14.3 Open access opening on top of ion-exchange equipment. Drain water, just to the top of the bed. (**Warning**—If the ion-exchange unit has been operating at temperatures above 100°C (212°F) it should be cooled prior to opening to avoid flashing.)

15. Sampling Procedure

15.1 Select a minimum of six points evenly spaced, and if possible, on a circle approximately two thirds the diameter of the bed.

15.2 Thrust the sampling rod (Fig. 3) through the ion-exchange material until the subfill or bed support can be felt. (**Warning**—Care should be exercised not to damage internal parts, especially in the case of interfacial distributors in mixed bed units.)

15.3 With a gentle up and down motion, slip the sampling tube (Fig. 1) over the top of the sample rod and through the ion-exchange material to seat on the upper conical stopper (Fig. 4).

15.4 Pull up on the rod to withdraw the sample tube.

⁴ The sole source of supply of the apparatus known to the committee at this time as the Bead Thief (trademark) is from IX Services Company, 29 Pinon St., P.O. Box 326, Bluewater, NM 87005. If you are aware of alternative suppliers, please provide this information to ASTM International Headquarters. Your comments will receive careful consideration at a meeting of the responsible technical committee,¹ which you may attend.

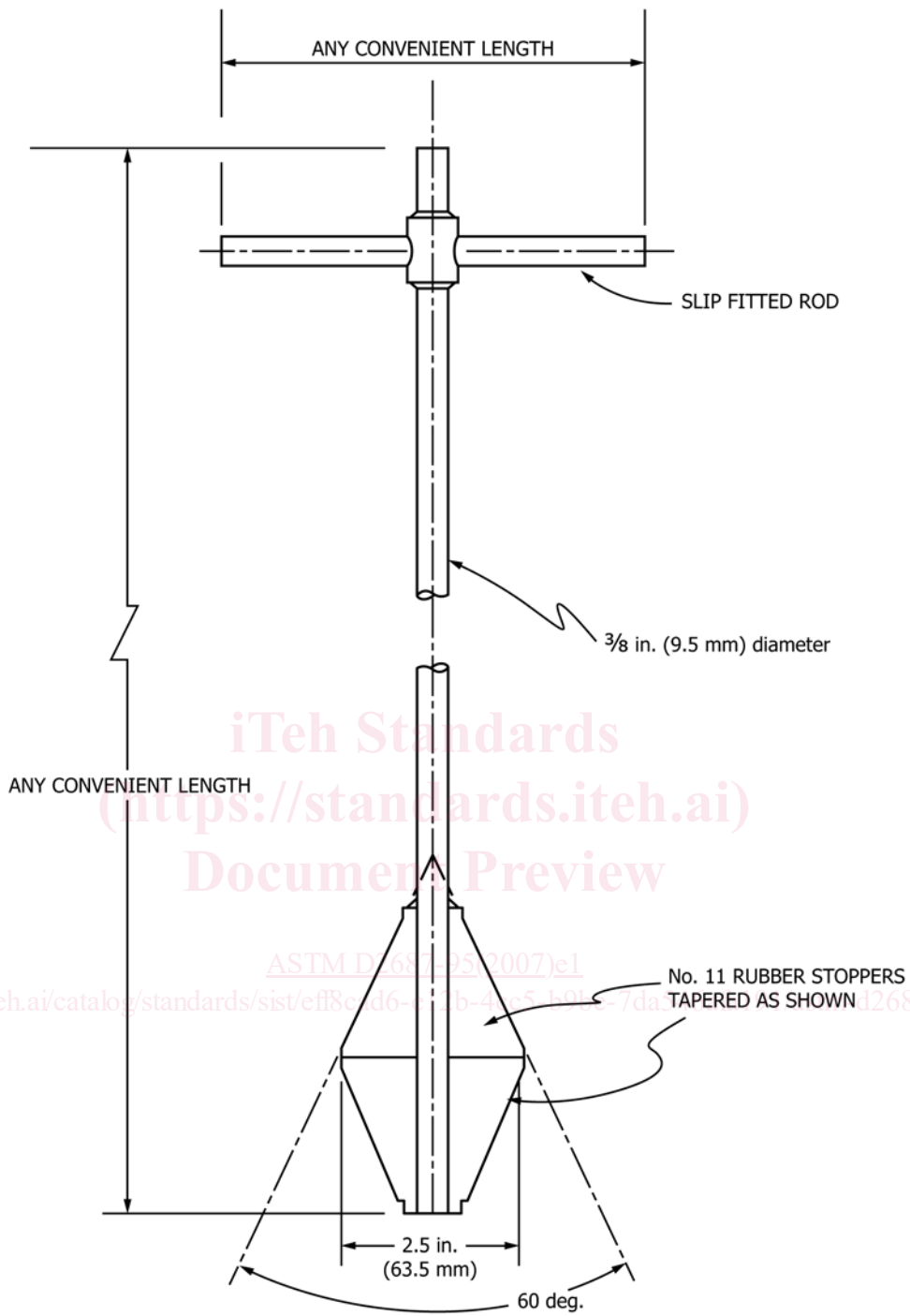

FIG. 3 Sampling Rod

15.5 Check to make certain the tube is filled. It may take several attempts to perfect this technique and obtain a full sample tube.

15.6 Empty the contents into the sample container.

15.7 Repeat steps 15.2 through 15.6 until sufficient sample is obtained (a minimum of six probes or increments is required).

15.8 Alternatively, a core sampler (Fig. 7) may be used to obtain the minimum six increments at points located according

to 15.1. The sampler must reach to within the bottom 50 mm (2 in.) of the ion-exchange bed.

15.9 Seal the sample container.

15.10 If the sample obtained is larger than required, reduce the sample using the quartering technique given in Section 10.

16. Sample Labeling

16.1 Immediately upon placing each sample in its sample container, affix a label or tag to the container with the