



SLOVENSKI STANDARD

SIST EN 755-8:2016

01-september-2016

Nadomešča:
SIST EN 755-8:2008

Aluminij in aluminijeve zlitine - Iztiskane palice/drogovi, cevi in profili - 8. del: Z večdelnimi matricami iztiskane cevi, tolerance mer in oblike

Aluminium and aluminium alloys - Extruded rod/bar, tube and profiles - Part 8: Porthole tubes, tolerances on dimensions and form

Aluminium und Aluminiumlegierungen - Stranggepresste Stangen, Rohre und Profile - Teil 8: Mit Kammerwerkzeug stranggepresste Rohre, Grenzabmaße und Formtoleranzen
(standards.iteh.ai)

Aluminium et alliages d'aluminium - Barres, tubes et profilés filés - Partie 8 : Tubes filés à pont, tolérances sur dimensions et forme
standards/iteh.ai/standards/sist/df425dfe-a923-4d8b-ac77-e396fd0bee00/sist-en-755-8-2016

Ta slovenski standard je istoveten z: EN 755-8:2016

ICS:

77.150.10 Aluminijski izdelki Aluminium products

SIST EN 755-8:2016 **en,fr,de**

iTeh STANDARD PREVIEW
(standards.iteh.ai)

[SIST EN 755-8:2016](#)

<https://standards.iteh.ai/catalog/standards/sist/df425dfe-a923-4d8b-ac77-e396fd0bee00/sist-en-755-8-2016>

EUROPEAN STANDARD

EN 755-8

NORME EUROPÉENNE

EUROPÄISCHE NORM

June 2016

ICS 77.150.10

Supersedes EN 755-8:2008

English Version

Aluminium and aluminium alloys - Extruded rod/bar, tube and profiles - Part 8: Porthole tubes, tolerances on dimensions and form

Aluminium et alliages d'aluminium - Barres, tubes et profilés filés - Partie 8 : Tubes filés à pont, tolérances sur dimensions et forme

Aluminium und Aluminiumlegierungen - Stranggepresste Stangen, Rohre und Profile - Teil 8: Mit Kammerwerkzeug stranggepresste Rohre, Grenzabmaße und Formtoleranzen

This European Standard was approved by CEN on 11 April 2016.

CEN members are bound to comply with the CEN/CENELEC Internal Regulations which stipulate the conditions for giving this European Standard the status of a national standard without any alteration. Up-to-date lists and bibliographical references concerning such national standards may be obtained on application to the CEN-CENELEC Management Centre or to any CEN member.

This European Standard exists in three official versions (English, French, German). A version in any other language made by translation under the responsibility of a CEN member into its own language and notified to the CEN-CENELEC Management Centre has the same status as the official versions.

CEN members are the national standards bodies of Austria, Belgium, Bulgaria, Croatia, Cyprus, Czech Republic, Denmark, Estonia, Finland, Former Yugoslav Republic of Macedonia, France, Germany, Greece, Hungary, Iceland, Ireland, Italy, Latvia, Lithuania, Luxembourg, Malta, Netherlands, Norway, Poland, Portugal, Romania, Slovakia, Slovenia, Spain, Sweden, Switzerland, Turkey and United Kingdom.



EUROPEAN COMMITTEE FOR STANDARDIZATION
COMITÉ EUROPÉEN DE NORMALISATION
EUROPÄISCHES KOMITEE FÜR NORMUNG

CEN-CENELEC Management Centre: Avenue Marnix 17, B-1000 Brussels

Contents	Page
European foreword.....	3
1 Scope	4
2 Normative references	5
3 Tolerances on dimensions	5
3.1 General.....	5
3.2 Diameter - Round tube.....	5
3.3 Width, depth or width across flats - squares, rectangles, hexagons, octagons.....	6
3.4 Wall thickness variation (eccentricity).....	7
3.5 Length.....	8
3.6 Squareness of cut ends.....	9
4 Tolerances on form	9
4.1 General.....	9
4.2 Straightness.....	9
4.3 Convexity-Concavity.....	10
4.4 Twist.....	11
4.5 Angularity.....	12
4.6 Corner and fillet radii.....	13
4.7 Depth of dents for round tube.....	14
Annex A (informative) Wall thickness variation (eccentricity)	15
A.1 General.....	15
A.2 Specifying round tube sizes and tolerances.....	15
A.2.1 General.....	15
A.2.2 Wall thickness variation for tubes specified as $OD \times t$ or $ID \times t$	15
A.2.3 Wall thickness variation for tubes specified as $OD \times ID$	16
Bibliography	17

European foreword

This document (EN 755-8:2016) has been prepared by Technical Committee CEN/TC 132 “Aluminium and aluminium alloys”, the secretariat of which is held by AFNOR.

This European Standard shall be given the status of a national standard, either by publication of an identical text or by endorsement, at the latest by December 2016, and conflicting national standards shall be withdrawn at the latest by December 2016.

Attention is drawn to the possibility that some of the elements of this document may be the subject of patent rights. CEN [and/or CENELEC] shall not be held responsible for identifying any or all such patent rights.

This document supersedes EN 755-8:2008.

The following technical modifications have been introduced during the revision:

- Figure 1;
- Subclause 3.2 Diameter - Round tube.

EN 755 comprises the following parts under the general title *Aluminium and aluminium alloys — Extruded rod/bar, tube and profiles*:

- *Part 1: Technical conditions for inspection and delivery;*
- *Part 2: Mechanical properties;* [SIST EN 755-8:2016](https://standards.iteh.ai/catalog/standards/sist/df425dfe-a923-4d8b-ac77-e396fd0bee00/sist-en-755-8-2016)
- *Part 3: Round bars, tolerances on dimensions and form;*
- *Part 4: Square bars, tolerances on dimensions and form;*
- *Part 5: Rectangular bars, tolerances on dimensions and form;*
- *Part 6: Hexagonal bars, tolerances on dimensions and form;*
- *Part 7: Seamless tubes, tolerances on dimensions and form;*
- *Part 8: Porthole tubes, tolerances on dimensions and form;*
- *Part 9: Profiles, tolerances on dimensions and form.*

According to the CEN/CENELEC Internal Regulations, the national standards organizations of the following countries are bound to implement this European Standard: Austria, Belgium, Bulgaria, Croatia, Cyprus, Czech Republic, Denmark, Estonia, Finland, Former Yugoslav Republic of Macedonia, France, Germany, Greece, Hungary, Iceland, Ireland, Italy, Latvia, Lithuania, Luxembourg, Malta, Netherlands, Norway, Poland, Portugal, Romania, Slovakia, Slovenia, Spain, Sweden, Switzerland, Turkey and the United Kingdom.

1 Scope

This European Standard specifies the tolerances on dimensions and form for aluminium and aluminium alloy extruded porthole tubes with an outside diameter (OD) from 8 mm to 450 mm (round tube, see Figure 1) or with a cross section contained within a circumscribing circle (CD) from 10 mm to 350 mm (other than round tube, see Figure 2), supplied in straight lengths.

This European Standard only applies to extruded porthole tube for general engineering applications made in the following alloys:

- EN AW-1050A, EN AW-1200, EN AW-1350;
- EN AW-3003, EN AW-3103;
- EN AW-5005, EN AW-5005A, EN AW-5049, EN AW-5051A, EN AW-5251, EN AW-5052;
- EN AW-6101A, EN AW-6101B, EN AW-6005, EN AW-6005A, EN AW-6008, EN AW-6110A, EN AW-6012, EN AW-6014, EN AW-6018, EN AW-6351, EN AW-6060, EN AW-6360, EN AW-6061, EN AW-6261, EN AW-6262, EN AW-6262A, EN AW-6063, EN AW-6063A, EN AW-6463, EN AW-6065, EN AW-6081, EN AW-6082; EN AW-6182;
- EN AW-7003, EN AW-7005, EN AW-7108, EN AW-7108A, EN AW-7020.

The temper designations used in this part are according to EN 515.

This European Standard only applies to tube produced by the tube porthole/bridge method.

This European Standard does not apply to:

- extruded tubes produced by the seamless, die/mandrel method (EN 755-7),
- tubes delivered in coils (EN 13957),
- coiled tubes cut to length (EN 13957).

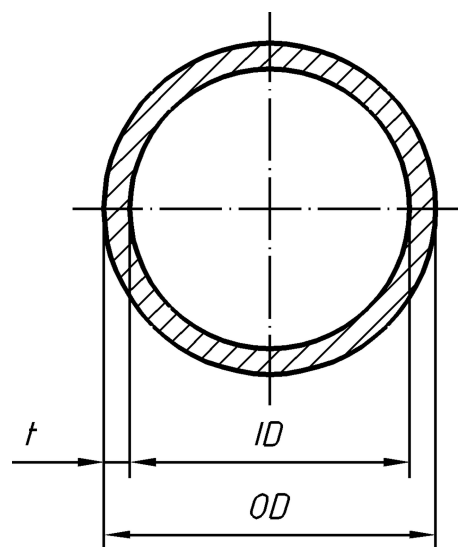

Figure 1 — Round tube

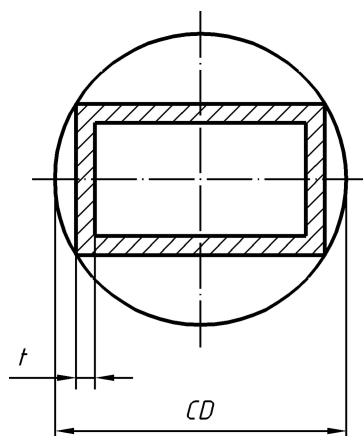

Figure 2 — Circumscribing circle for other than round tube

2 Normative references

The following documents, in whole or in part, are normatively referenced in this document and are indispensable for its application. For dated references, only the edition cited applies. For undated references, the latest edition of the referenced document (including any amendments) applies.

EN 755-1:2016, *Aluminium and aluminium alloys — Extruded rod/bar, tube and profiles — Part 1: Technical conditions for inspection and delivery*

(standards.iteh.ai)

3 Tolerances on dimensions SIST EN 755-8:2016

<https://standards.iteh.ai/catalog/standards/sist/df425dfe-a923-4d8b-ac77-e396fd0bee00/sist-en-755-8-2016>

3.1 General

When outside diameter OD , inside diameter ID , and wall thickness t (or their equivalent dimensions in other than round tube) are all specified, standard tolerances shall apply to any two of these dimensions, but not to all three. As a result, the purchaser shall only state two nominal dimensions on any given order.

3.2 Diameter - Round tube

Mean diameter is defined as the average of two diameter measurements taken at right angles to each other at any position along the length.

The maximum allowable deviation of diameter at any point from the specified diameter is the maximum difference measured at any point along the length of the tube ie it is inclusive of any ovality in the cross section.

The tolerances on diameter are specified in Table 1.

As detailed in EN 755-1:2016, Clause 4, if the original order does not make clear the nature of the diameter tolerances required, the supplier shall interpret them as inclusive of any ovality (i.e. maximum allowable deviation at any point from the specified diameter in Table 1). However, the diameter tolerances may be expressed as both mean and inclusive of ovality if this is specifically requested by the purchaser.

Table 1 — Tolerances on diameter for round tube

Dimensions in millimetres

Diameter (OD or ID)		Tolerance on diameter			
		Maximum allowable deviation of mean diameter from specified diameter ^f	Maximum allowable deviation of diameter at any point from specified diameter ^a		
Over	Up to and including		Non-annealed and non heat treated tube ^b	Heat treated tube ^c	Annealed tube ^d
≥ 8	18	±0,25 ^e	±0,40 ^e	±0,60 ^e	±1,5 ^e
18	30	±0,30	±0,50	±0,70	±1,8
30	50	±0,35	±0,60	±0,90	±2,2
50	80	±0,40	±0,70	±1,1	±2,6
80	120	±0,60	±0,90	±1,4	±3,6
120	200	±0,90	±1,4	±2,0	±5,0
200	350	±1,4	±1,9	±3,0	±7,6
350	450	±1,9	±2,8	±4,0	±10,0

^a Not applicable to tubes having a wall thickness less than 2,5 % of the specified outside diameter. The tolerance for tubes with wall thickness less than 2,5 % of the specified outside diameter shall be determined by multiplying the applicable tolerance as follows:

- wall thickness over 2,0 % up to and including 2,5 % of outside diameter: 1,5 × tolerance;
- wall thickness over 1,5 % up to and including 2,0 % of outside diameter: 2,0 × tolerance;
- wall thickness over 1,0 % up to and including 1,5 % of outside diameter: 3,0 × tolerance;
- wall thickness over 0,5 % up to and including 1,0 % of outside diameter: 4,0 × tolerance.

^b Applies to all alloys in F or H112 tempers.

^c Applies to all alloys in T4, T5, T6, T64, T66 and Tx511 tempers.

^d Applies to all alloys in O, H111 and Tx510 tempers.

^e This tolerance applies for outside diameter only, i.e. tube in this size range can only be specified as “Outside Diameter x Wall Thickness”.

^f Not applicable to Tx510 or Tx511 tempers.

3.3 Width, depth or width across flats - squares, rectangles, hexagons, octagons

The tolerances on width, depth or width across flats are specified in Table 2.

Table 2 — Tolerances on width, depth or width across flats

Dimensions in millimetres

Width, depth or width across flats		Tolerances on width, depth or width across flats ^{a, b}							
		$CD \leq 100$		$100 < CD \leq 200$		$200 < CD \leq 300$		$300 < CD \leq 350$	
Over	Up to and including	Column I _c	Column II _d	Column I _c	Column II _d	Column I _c	Column II _d	Column I _c	Column II _d
-	10	±0,25	±0,40	±0,30	±0,50	±0,35	±0,55	±0,40	±0,60
10	25	±0,30	±0,50	±0,40	±0,70	±0,50	±0,80	±0,60	±0,90
25	50	±0,50	±0,80	±0,60	±0,90	±0,80	±1,0	±0,90	±1,2
50	100	±0,70	±1,0	±0,90	±1,2	±1,1	±1,3	±1,3	±1,6
100	150	-	-	±1,1	±1,5	±1,3	±1,7	±1,5	±1,8
150	200	-	-	±1,3	±1,9	±1,5	±2,2	±1,8	±2,4
200	300	-	-	-	-	±1,7	±2,5	±2,1	±2,8
300	350	-	-	-	-	-	-	±2,8	±3,5

^a Not applicable to tubes having a wall thickness less than 2,5 % of the specified outside width, depth or width across flats. The tolerance for tubes with wall thickness less than 2,5 % of the specified width, depth or width across flats shall be determined by multiplying the applicable tolerance as follows:

- wall thickness over 2,0 % up to and including 2,5 % of outside parameter: 1,5 × tolerance;
- wall thickness over 1,5 % up to and including 2,0 % of outside parameter: 2,0 × tolerance;
- wall thickness over 1,0 % up to and including 1,5 % of outside parameter: 3,0 × tolerance;
- wall thickness over 0,5 % up to and including 1,0 % of outside parameter: 4,0 × tolerance.

^b These tolerances do not apply to tempers O and Tx510. For these tempers the tolerances shall be subject to agreement between supplier and purchaser.

^c Column I is applicable to alloys mentioned in Clause 1 with exception of the alloys indicated in Footnote ^d of the table.

^d Column II is applicable to the following alloys: EN AW-5051A, EN AW-5251, EN AW-5049, EN AW-5052, EN AW-6110A, EN AW-6012, EN AW-6018, EN AW-6351, EN AW-6061, EN AW-6262, EN AW-6081, EN AW-6082, EN AW-7003, EN AW-7005, EN AW-7108, EN AW-7108A, EN AW-7020.

3.4 Wall thickness variation (eccentricity)

The tolerances on wall thickness variation (eccentricity) for round tubes are specified in Table 3 and wall thickness variation for other than round tubes in Table 4.