



## Standard Test Method for Density and Relative Density (Specific Gravity) of Viscous Materials by Lipkin Bicapillary Pycnometer<sup>1</sup>

This standard is issued under the fixed designation D 1481; the number immediately following the designation indicates the year of original adoption or, in the case of revision, the year of last revision. A number in parentheses indicates the year of last reapproval. A superscript epsilon ( $\epsilon$ ) indicates an editorial change since the last revision or reapproval.

### 1. Scope

1.1 This test method covers the determination of the density of oils more viscous than 15 cSt at 20°C (mm<sup>2</sup>/s), and of viscous oils and melted waxes at elevated temperatures, but not at temperatures at which the sample would have a vapor pressure of 100 mm Hg (13 kPa) or above.

NOTE 1—To determine the densities of less viscous liquids at 20 or 25°C use Test Method ~~D941~~ or Test Method D 1217.

1.2 This test method provides a calculation procedure for converting density to relative density (specific gravity).

~~1.3 The values stated in acceptable SI units are to be regarded as the standard.~~

1.3 The values stated in SI units are to be regarded as the standard. The values given in parentheses are for information only.

1.4 *This standard does not purport to address all of the safety concerns, if any, associated with its use. It is the responsibility of the user of this standard to establish appropriate safety and health practices and determine the applicability of regulatory limitations prior to use.*

### 2. Referenced Documents

2.1 *ASTM Standards: ~~D941~~ Test Method for Density and Relative Density (Specific Gravity) of Liquids by Lipkin Bicapillary Pycnometer<sup>2</sup>*

~~D 1217 Test Method for Density and Relative Density (Specific Gravity) of Liquids by Bingham Pycnometer<sup>2</sup>~~ Test Method for Process Control Verification to Prevent Hydrogen Embrittlement in Plated or Coated Fasteners

~~D 1250 Guide for Petroleum Measurement Tables<sup>2</sup>~~ Test Method for Process Control Verification to Prevent Hydrogen Embrittlement in Plated or Coated Fasteners

### 3. Terminology

3.1 *Definitions:*

3.1.1 *density*—the weight in a vacuum (that is, the mass) of a unit volume of the material at any given temperature.

3.1.2 *relative density (specific gravity)*—the ratio of the mass (weight in a vacuum) of a given volume of material at a temperature,  $t_1$ , to the mass of an equal volume of water at a reference temperature,  $t_2$ ; or the ratio of the density of the material at  $t_1$  to the density of water at  $t_2$ .

### 4. Summary of Test Method<sup>3</sup>

4.1 The liquid is drawn into the bicapillary pycnometer through the removable siphon arm and adjusted to volume at the temperature of test, in such a manner that there is practically no drainage in the unfilled tubing. After equilibration at the test temperature, liquid levels are read, and the pycnometer is removed from the thermostated bath, cooled to room temperature, and weighed.

4.2 Density or relative density (specific gravity), as desired, is then calculated from the volume at the test temperature and the weight of the sample. The effect of air buoyancy is included in the calculations.

<sup>4</sup> This test method is under the jurisdiction of ASTM Committee D-2 on Petroleum Products and Lubricants and is the direct responsibility of Subcommittee D02.04 on Hydrocarbon Analysis.

Current edition approved Feb. 15, 1993. Published June 1993. Originally published as D1481-57T. Last previous edition D1481-91.

<sup>1</sup> This test method is under the jurisdiction of ASTM Committee D02 on Petroleum Products and Lubricants and is the direct responsibility of Subcommittee D02.04.0D on Physical and Chemical Methods.

Current edition approved Nov. 1, 2007. Published January 2008. Originally approved in 1957. Last previous edition approved in 2002 as D 1481-02.

<sup>2</sup> Annual book of ASTM Standards, Vol 05.01.

<sup>2</sup> For referenced ASTM standards, visit the ASTM website, [www.astm.org](http://www.astm.org), or contact ASTM Customer Service at [service@astm.org](mailto:service@astm.org). For Annual Book of ASTM Standards volume information, refer to the standard's Document Summary page on the ASTM website.

<sup>3</sup> For a more complete discussion of this procedure, see Lipkin, M. R., Mills, I. W., Martin, C. C., and Harvey, W. T., *Analytical Chemistry*, ANCHA, Vol 21, 1949, p. 504.

## 5. Significance and Use

5.1 Density is a fundamental physical property that can be used in conjunction with other properties to characterize both the light and heavy fractions of petroleum and to access the quality of crude oils.

5.2 Determination of the density or relative density of petroleum and its products is necessary for the conversion of measured volumes to volumes at the standard temperatures of 15°C.

5.3 The determination of densities at the elevated temperatures of 40 and 100°C is particularly useful in providing the data needed for the conversion of kinematic viscosities in centistokes ( $\text{mm}^2/\text{s}$ ) to the corresponding dynamic viscosities in centipoises ( $\text{mPa}\cdot\text{s}$ ).

## 6. Apparatus

6.1 *Pycnometer*<sup>4</sup>—A side-arm type of pycnometer conforming to the dimensions given in Fig. 1 and made of borosilicate glass. The weight shall not exceed 35 g without the side arm.

6.2 *Rack*—A rack to use in filling the pycnometer (see Fig. 2).

6.3 *Constant-Temperature Oven*—An oven for use in filling the pycnometer. Any oven capable of holding the filling rack, and of maintaining a temperature of approximately 100°C, can be used.

6.4 *Constant-Temperature Bath*—A mixture of water and glycerin, or oil bath having a depth of at least 305 mm (12 in.) and provided with heating, stirring, and thermostating devices adequate to maintain desired temperatures in the range from 20 to 100°C with an accuracy of  $\pm 0.01^\circ\text{C}$ .

6.5 *Bath Thermometers*—Thermometers graduated in  $0.1^\circ\text{C}$  subdivisions and standardized for the range of use to the nearest  $0.01^\circ\text{C}$  (ASTM Saybolt Viscosity Thermometers 17C to 22C are recommended). For most hydrocarbons, the density coefficient is about  $0.0008 \text{ units}/^\circ\text{C}$ , and therefore a temperature error of  $\pm 0.013^\circ\text{C}$  would cause an error of  $\pm 0.00001$  in density.

6.6 *Pycnometer Holder*—A holder, as shown in Fig. 3, is recommended for supporting the pycnometer in the bath. A single clamp device may be used.

6.7 *Balance*—A balance able to reproduce weighings within 0.1 mg when carrying a load of 35 g or less on each pan. The balance shall be located in a room shielded from drafts and fumes and in which the temperature changes between related weighings (empty and filled pycnometer) do not cause a significant change in the ratio of the balance arms. Otherwise, weighings shall be made by the substitution method in which the calibrated weights and pycnometer are alternatively weighed on the same balance pan. The same balance shall be used for all related weighings.

6.8 *Weights*—Weights shall be used whose relative values are known to the nearest 0.05 mg or better. The same set of weights shall be used for the calibration of the pycnometer and the determination of the densities, or the sets of weights shall be calibrated relative to each other.

<sup>4</sup> Pycnometers available from Reliance Glass Co., 220 Gateway Rd., Bensenville, IL 60106-0825 have been found satisfactory.

<sup>4</sup> The sole source of supply of the pycnometers known to the committee at this time is Reliance Glass Co., 220 Gateway Rd., Bensenville, IL 60106-0825 have been found satisfactory. If you are aware of alternative suppliers, please provide this information to ASTM International Headquarters. Your comments will receive careful consideration at a meeting of the responsible technical committee, which you may attend.

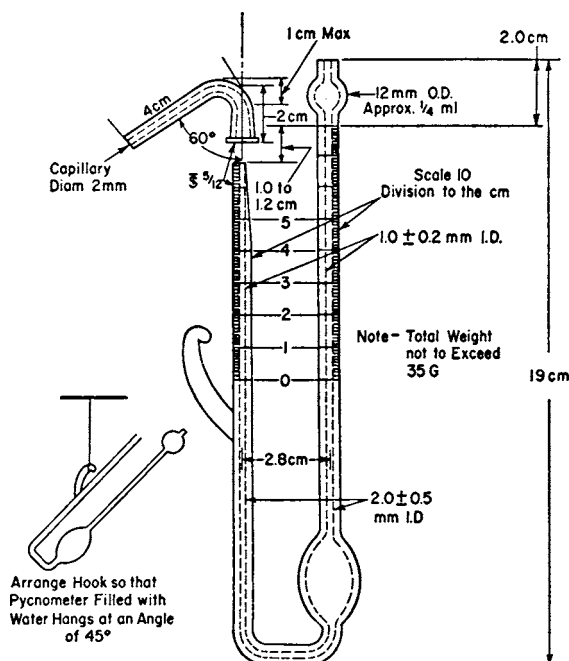

FIG. 1 Pycnometer

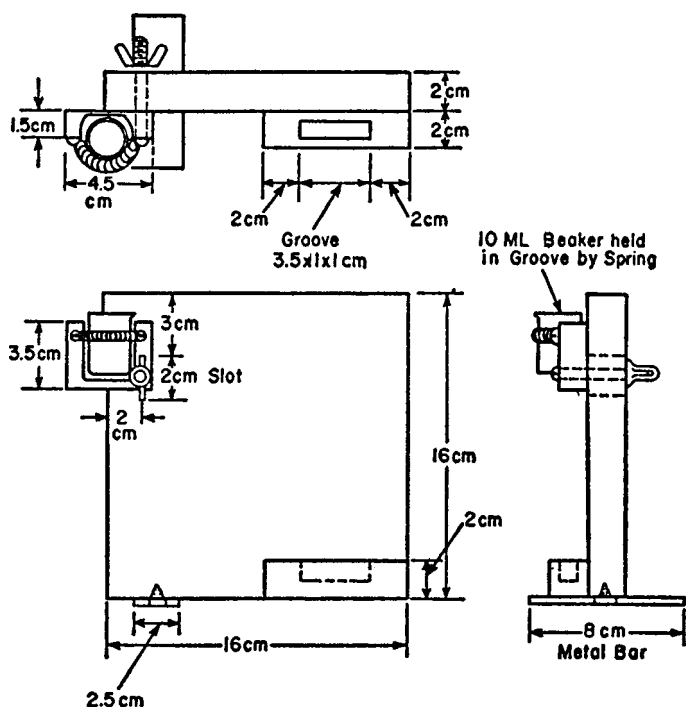

FIG. 2 Rack for Filling Pycnometer

## 7. Reagents and Materials

7.1 *Acetone*—(Warning—Extremely flammable. Use adequate ventilation.)

7.2 *Isopentane*—(Warning—Extremely flammable. Avoid buildup of vapors and remove all sources of ignition, especially nonexplosion-proof electrical apparatus.)

7.3 *Chromic Acid (Potassium Dichromate/Conc. Sulfuric Acid)*—(Warning—Causes severe burns. A recognized carcinogen. Do not get in eyes, on skin or clothing.)

7.4 *Benzene—Xylenes*—(Warning—Poison. Known carcinogen. Extremely flammable. Avoid contact with skin and eyes.—Flammable liquid. Aspiration hazard. May irritate skin, eyes, respiratory tract or digestive tract, or both. May cause central nervous system depression, liver and kidney damage, or exhibit reproductive and fetal effects, or both.)

## 8. Preparation of Apparatus

8.1 Thoroughly clean the pycnometer and side arm with hot chromic acid cleaning solution (Warning—See 7.4.). Chromic acid solution is the most effective cleaning agent. However, surfactant cleaning fluids have also been used successfully. Rinse well with distilled water; and dry at 105 to 110°C for at least 1 h, preferably with a slow current of filtered air passing through the pycnometer. Cleaning shall be done in this manner whenever the pycnometer is to be calibrated or whenever liquid fails to drain cleanly from the walls of the pycnometer or its capillary. Ordinarily, the pycnometer may be cleaned between determinations by washing with a suitable solvent, such as isopentane or benzene, xylenes, and vacuum drying. If acetone is used as the wash liquid, the pycnometer should then be rinsed with isopentane or benzene, xylenes.

## 9. Calibration of Pycnometer

9.1 Weigh the clean, dry pycnometer (without the side arm) to the nearest 0.1 mg, and record the weight.

9.2 Fill the pycnometer with freshly boiled distilled water. This may be conveniently done by placing the pycnometer in the holder with the side arm dipping into a sample cup containing water. Allow the pycnometer to fill by siphoning. Break the siphon by removing the side arm when the liquid level in the bulb arm of the pycnometer reaches 6 on the scale.

9.3 Remove the side arm which was used to fill the pycnometer and remove excess liquid from the capillary tip by wiping with a small piece of absorbent paper.

9.4 Place the pycnometer in the holder in the constant-temperature bath at temperature  $t$  with the liquid level in the capillaries below the liquid level in the bath. When the liquid level has reached equilibrium (not less than 15 min), read the scale to the nearest 0.2 small division at the liquid level in each arm. After 5 min, read the liquid level again. If the sum of the scale readings in each reading differs by more than  $\pm 0.04$ , repeat readings at 5-min intervals. When readings are constant, record.

9.5 Remove the pycnometer from the bath and allow it to come to room temperature. Rinse the outer surface with distilled water, with acetone, then with redistilled benzene, xylenes, and dry thoroughly with a chemically clean lint-free cloth, slightly damp with water. Allow to stand a few minutes, and then weigh to nearest 0.1 mg.