



# Standard Specification for Manhole Cover Assembly, Bolted, Semi-Flush, Oiltight and Watertight, Hinged<sup>1</sup>

This standard is issued under the fixed designation F1144; the number immediately following the designation indicates the year of original adoption or, in the case of revision, the year of last revision. A number in parentheses indicates the year of last reapproval. A superscript epsilon ( $\epsilon$ ) indicates an editorial change since the last revision or reapproval.

## 1. Scope

1.1 This specification provides design and construction criteria for a semi-flush, oiltight and watertight bolted hinged manhole cover assembly.

1.2 The manhole cover assemblies depicted on this specification are for use in decks or bulkheads requiring oiltight and watertight covers that are not required to be completely flush. Manhole cover assemblies shall be complete with covers, mounting rings, gaskets, studs, washers, hinge assemblies, and nuts.

1.3 Handles, if required, shall be as specified in the ordering information.

1.4 Values stated in inch-pound units are to be regarded as standard.

1.5 This standard is not applicable to certain hazardous cargos. (See 46CFR 153.254 and 46CFR 154.340.)

1.6 This specification provides design and construction for manhole cover assemblies subjected to lateral pressures such as resulting from vehicle loads or hydrostatic pressures. Where manhole cover assemblies are subjected to primary or cyclic loads, other reinforcement or construction criteria may be necessary to integrate the manhole assembly with the required structural reinforcement for openings in decks or bulkheads. Design of the manhole cover assembly for primary or cyclic loads is beyond the scope of this specification.

## 2. Referenced Documents

### 2.1 ASTM Standards:<sup>2</sup>

- A36/A36M Specification for Carbon Structural Steel
- A131/A131M Specification for Structural Steel for Ships
- A153/A153M Specification for Zinc Coating (Hot-Dip) on

<sup>1</sup> This specification is under the jurisdiction of ASTM Committee F25 on Ships and Marine Technology and is the direct responsibility of Subcommittee F25.03 on Outfitting and Deck Machinery.

Current edition approved Dec. 1, 2007. Published January 2008. Originally approved in 1988. Last previous edition approved in 2003 as F1144 – 98(2003). DOI: 10.1520/F1144-98R07.

<sup>2</sup> For referenced ASTM standards, visit the ASTM website, [www.astm.org](http://www.astm.org), or contact ASTM Customer Service at [service@astm.org](mailto:service@astm.org). For *Annual Book of ASTM Standards* volume information, refer to the standard's Document Summary page on the ASTM website.

### Iron and Steel Hardware

- A575 Specification for Steel Bars, Carbon, Merchant Quality, M-Grades
- B36/B36M Specification for Brass Plate, Sheet, Strip, and Rolled Bar
- D2000 Classification System for Rubber Products in Automotive Applications
- F783 Specification for Staple, Handgrab, Handle, and Stirrup Rung

### 2.2 ANSI Standards:

- B1.1 Unified Inch Screw Threads<sup>3</sup>
- Y14.5M Dimensioning and Tolerancing<sup>3</sup>
- B18.2.1 Square and Hex Bolts and Screws, Inch Series<sup>3</sup>

### 2.3 ABS Standard:

- Rules for Building and Classing Steel Vessels<sup>4</sup>
- 2.4 Steel Structures Painting Council Standard: SP-10 Surface Preparation Specification No. 10<sup>5</sup>
- 2.5 Code of Federal Regulations Standard: CFR 46 Code of Federal Regulations<sup>6</sup>

## 3. Terminology

### 3.1 Definitions:

- 3.1.1 *manhole*—accessway located in a tank structure.
- 3.1.2 *semi-flush*—refers to the placement of the hinged plate over the ringed opening (without coaming).

## 4. Classification

- 4.1 Type I—15- by 23-in. (381- by 584-mm) size of access opening
- 4.2 Type II—18- by 24-in. (457- by 610-mm) size of access opening
- 4.3 Grade 1— $\frac{1}{4}$ -in. (6.4-mm) thick cover plate

<sup>3</sup> Available from American National Standards Institute (ANSI), 25 W. 43rd St., 4th Floor, New York, NY 10036, <http://www.ansi.org>.

<sup>4</sup> Available from American Bureau of Shipping (ABS), ABS Plaza, 16855 Northchase Dr., Houston, TX 77060, <http://www.eagle.org>.

<sup>5</sup> Available from Society for Protective Coatings (SSPC), 40 24th St., 6th Floor, Pittsburgh, PA 15222-4656, <http://www.sspc.org>.

<sup>6</sup> Available from Standardization Documents Order Desk, DODSSP, Bldg. 4, Section D, 700 Robbins Ave., Philadelphia, PA 19111-5098, <http://www.dodssp.daps.mil>.

4.4 Grade 2— $\frac{3}{8}$ -in. (9.5-mm) thick cover plate

4.5 Grade 3— $\frac{1}{2}$ -in. (12.7-mm) thick cover plate

4.6 *Class A Manhole Cover Assemblies*— Shall be abrasive blasted to near white metal in accordance with SSPC SP-10 and a commercial marine quality nonhazardous corrosion-inhibiting and oil-resistant primer coating be applied for protection for a period of one year during shipping and in shipyard handling.

4.7 *Class B Manhole Cover Assemblies*— Shall be galvanized in accordance with Specification **A153/A153M**.

## 5. Ordering Information

5.1 The purchasers ordering information shall include the following:

5.1.1 ASTM designation and date.

5.1.2 Type (see 4.1 and 4.2).

5.1.3 Grade (see 4.3, 4.4, and 4.5).

5.1.4 Class see (4.6 and 4.7).

5.1.5 Quantity.

5.1.6 Remarks—Handles (are/are not) required.

5.1.7 Approval—Classification society approval (is/is not) required.

5.1.8 Gasket, if other than specified (see 6.8).

## 6. Materials and Manufacture

6.1 Plate for the cover, ring, hinge pad and hinge blade shall be in accordance with Specification **A36/A36M** or **A131/A131M** steel.

6.2 Round bar for the handle shall be in accordance with Specification **F783**, Type A.

6.3 Round bar for the hinge pin shall be of Specification **A575** steel.

6.4 Welded studs shall be  $\frac{3}{4}$  in. (19.1 mm)—10 UNC-2A by  $1\frac{3}{4}$  in. (44.5 mm) long and manufactured of ordinary steel to commercial standards. Threads shall be the coarse thread series in accordance with the latest issue of ANSI B1.1.

6.5 Washers shall be ANSI B18.2.1 Type A,  $\frac{3}{4}$ -in. (19.1-mm) washer, 2-in. (50.8-mm) by 0.148-in. (3.8-mm) thick standard flat manufactured of yellow brass, in accordance with Specification **B36/B36M**.

6.6 Heavy hex nuts shall be  $\frac{3}{4}$  in. (19.1 mm)—10 UNC-2B and manufactured of yellow brass, in accordance with Specification **B36/B36M**. Threads in nuts shall conform to the dimensions for coarse threads with tolerances prescribed in accordance with ANSI B1.1. The nuts shall conform to dimensions prescribed in accordance with ANSI B18.2.1.

6.7 Cotter pin to be in accordance with Specification **B36/B36M** yellow brass,  $\frac{1}{8}$  by  $1\frac{3}{4}$  in. (3.2 by 44.5 mm) long.

6.8 Unless otherwise specified in ordering information, gasket to be rubber,  $\frac{3}{16}$  in. (4.8 mm) thick,  $50 \pm 5$  durometers per Classification **D2000** 5BC507 A14 E034. For manhole cover assemblies for government application, see **Annex A2** for type of gasket.

6.9 Welding to conform to the latest issue of American Bureau of Shipping Rules or other such classification society rules as may be applicable.

6.10 Details of bolted manholes are shown in **Fig. 1**.

## 7. Dimensions

7.1 Dimensions of manhole shall be as indicated in **Table 1**.

7.2 For plating up to and including  $\frac{1}{4}$ -in. (6.4-mm) thickness, use cover plate of  $\frac{1}{4}$ -in. (6.4-mm) thickness. Plating over  $\frac{1}{4}$ -in. (6.4-mm) up to and including  $\frac{3}{8}$ -in. (9.5-mm) thickness; use cover plate of  $\frac{3}{8}$ -in. (9.5-mm) thickness. Plating over  $\frac{3}{8}$ -in. (9.5-mm) thickness, use cover plate of  $\frac{1}{2}$ -in. (12.7-mm) thickness.

## 8. Finish

8.1 Items produced under this specification shall be free of splinters, sharp edges, burrs, projections, and weld spatters.

8.2 Unless otherwise specified in ordering data, items shall, after fabrication, have a Class A finish.

## 9. Sampling

9.1 For orders for one or two manhole cover assemblies, each manhole assembly shall be inspected.

9.2 For orders for three to ten manhole cover assemblies, two manhole cover assemblies shall be selected at random. If any one of them fails to meet requirements, then all manhole cover assemblies in the order shall be inspected.

9.3 For orders for more than ten manhole cover assemblies, they shall be separated into groups of ten (or fraction thereof) for sampling purposes.

## 10. Inspection and Testing

10.1 *Responsibility*—Unless otherwise specified in the order, the manufacturer is responsible for the performance of all inspection and testing specified herein. The manufacturer may use his own facilities or any commercial facility acceptable to the purchaser. The purchaser reserves the right to perform any of the inspections and tests set forth where such are deemed necessary to assure that supplies conform to prescribed requirements. Nonconforming manhole cover assemblies shall not be offered for delivery.

10.2 *Inspection*—The dimensions of the manhole cover assembly and its components shall be checked to ensure that they are within specified tolerances.

10.3 *Test Methods*—Each manhole cover assembly shall be designed to the pressure listed in **Table 1** and tested to a pressure equal to 1.5 times the design pressure. The test pressure shall be held for a minimum of 5 min. There shall be no visible sign of leakage, permanent deformation, or other indications of structural failure of the manhole cover assembly.

10.3.1 Before delivery, manhole cover assemblies shall be certified as to their watertight and oiltight integrity. Groups of manhole cover assemblies whose representative samples pass the tightness test shall be certified for watertight and oiltight integrity to their design pressure.

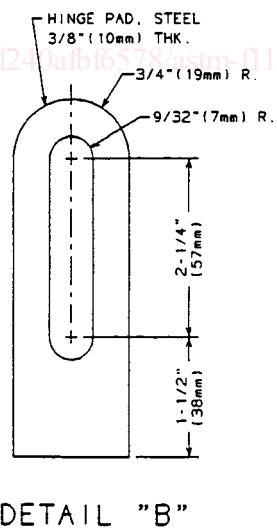
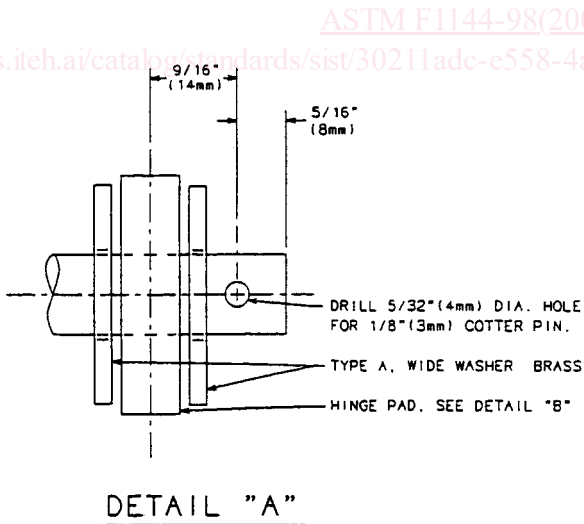
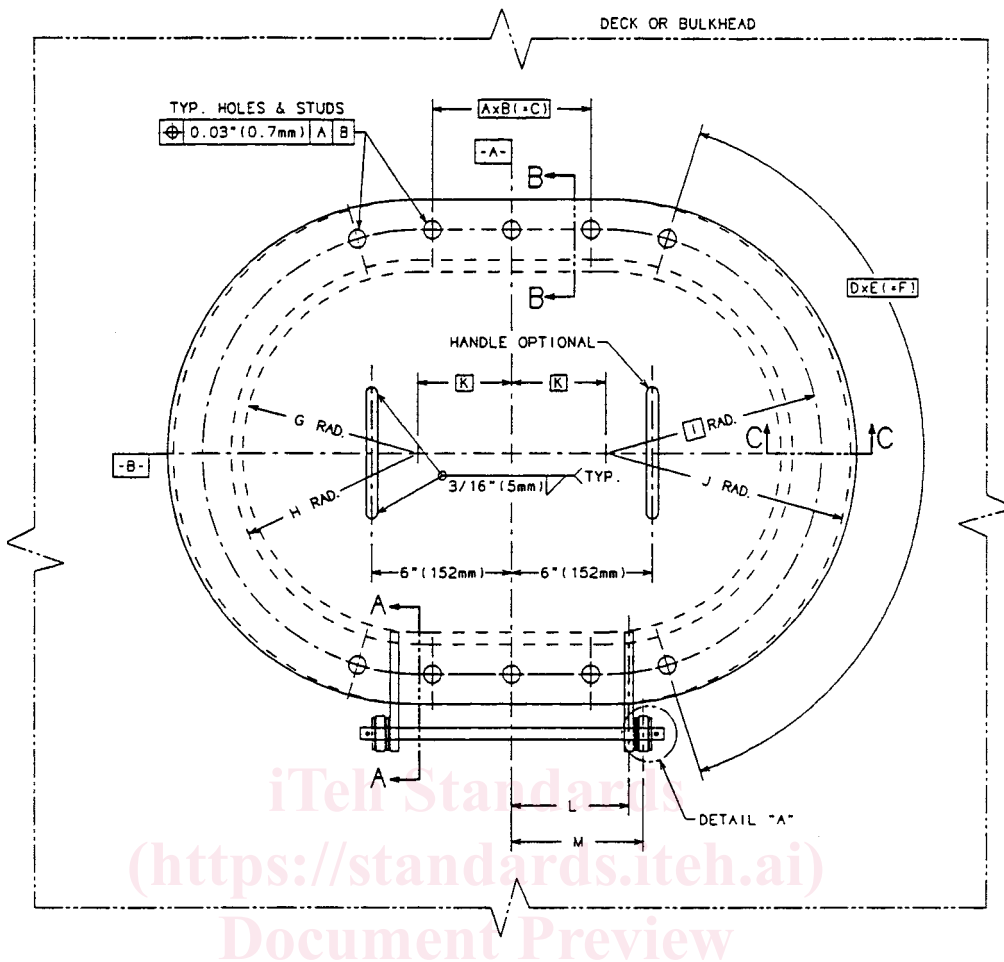

NOTE 1—1 in. = 25.4 mm.

FIG. 1 Manhole Cover Assembly, Bolted, Hinged, Semi-Flush, Oiltight and Watertight.

11. Product Marking

11.1 Each manhole cover assembly shall be marked with the purchase order number, item number from purchase order,

ASTM designation number, type, grade, class, and manufacturers' name. Marking may be by paint, stencil, or weather-proof tag.