Cisterne za prevoz nevarnega blaga - Digitalni vmesnik za napravo za prepoznavanje proizvoda za tekoča goriva

Tanks for transport of dangerous goods - Digital interface for product recognition devices for liquid fuels

Tanks für die Beförderung gefährlicher Güter - Digitale Schnittstelle für das Produkterkennungssystem für flüssige Kraft- und Brennstoffe

Citernes destinées au transport de matières dangereuses - Interface numérique du dispositif de reconnaissance de produits pétroliers

<https://standards.iteh.ai/catalog/standards/sist/76d28a8d-b082-4fd9-fae-095b8adac8cb/sist-en-14116-2012a1-2014>

Ta slovenski standard je istoveten z: EN 14116:2012+A1:2014

ICS:

13.300	Varstvo pred nevarnimi izdelki	Protection against dangerous goods
23.020.20	Posode in vsebniki, montirani na vozila	Vessels and containers mounted on vehicles
35.240.60	Uporabniške rešitve IT v transportu in trgovini	IT applications in transport and trade

SIST EN 14116:2012+A1:2014

en,fr,de

iTeh STANDARD PREVIEW
(standards.iteh.ai)

[SIST EN 14116:2012+A1:2014](#)

<https://standards.iteh.ai/catalog/standards/sist/76d28a8d-b082-4fd9-9fae-095b8adac8cb/sist-en-14116-2012a1-2014>

EUROPEAN STANDARD
NORME EUROPÉENNE
EUROPÄISCHE NORM

EN 14116:2012+A1

September 2014

ICS 13.300; 23.020.20; 35.240.60

Supersedes EN 14116:2012

English Version

Tanks for transport of dangerous goods - Digital interface for product recognition devices for liquid fuels

Citernes destinées au transport de matières dangereuses -
Interface numérique du dispositif de reconnaissance de
produits pétroliers

Tanks für die Beförderung gefährlicher Güter - Digitale
Schnittstelle für das Produkterkennungssystem für flüssige
Kraft- und Brennstoffe

This European Standard was approved by CEN on 1 September 2012 and includes Amendment 1 approved by CEN on 7 August 2014.

CEN members are bound to comply with the CEN/CENELEC Internal Regulations which stipulate the conditions for giving this European Standard the status of a national standard without any alteration. Up-to-date lists and bibliographical references concerning such national standards may be obtained on application to the CEN-CENELEC Management Centre or to any CEN member.

This European Standard exists in three official versions (English, French, German). A version in any other language made by translation under the responsibility of a CEN member into its own language and notified to the CEN-CENELEC Management Centre has the same status as the official versions.

CEN members are the national standards bodies of Austria, Belgium, Bulgaria, Croatia, Cyprus, Czech Republic, Denmark, Estonia, Finland, Former Yugoslav Republic of Macedonia, France, Germany, Greece, Hungary, Iceland, Ireland, Italy, Latvia, Lithuania, Luxembourg, Malta, Netherlands, Norway, Poland, Portugal, Romania, Slovakia, Slovenia, Spain, Sweden, Switzerland, Turkey and United Kingdom.

[SIST EN 14116:2012+A1:2014](https://standards.iteh.ai/catalog/standards/sist/76d28a8d-b082-4fdf-9fae-095b8adac8cb/sist-en-14116-2012a1-2014)

<https://standards.iteh.ai/catalog/standards/sist/76d28a8d-b082-4fdf-9fae-095b8adac8cb/sist-en-14116-2012a1-2014>



EUROPEAN COMMITTEE FOR STANDARDIZATION
COMITÉ EUROPÉEN DE NORMALISATION
EUROPÄISCHES KOMITEE FÜR NORMUNG

CEN-CENELEC Management Centre: Avenue Marnix 17, B-1000 Brussels

Contents

Page

Foreword.....	4
Introduction	5
1 Scope	6
2 Normative references	6
3 Terms, definitions and abbreviations.....	6
3.1 Terms and definitions	6
3.2 Abbreviations	7
4 Functions.....	8
5 Design characteristics	9
5.1 General.....	9
5.2 Temperature range	10
5.3 Materials of construction	10
5.4 PRD	10
5.5 PID	11
5.5.1 General specification	11
5.5.2 Diode and ESD protection	12
5.6 Contact and insulation resistances.....	13
5.7 Electrical requirements for hoses.....	13
5.8 System architecture of MultiPID.....	14
5.9 Electrical design characteristic of MultiPID.....	14
5.9.1 Technical description of MultiPID.....	14
5.9.2 Modulation for the bi-directional communication	16
5.9.3 Message timing.....	17
6 Protocol structure.....	18
6.1 Telegram transmission sequences.....	18
6.2 Bit coding	19
6.3 Byte frame	20
6.4 Byte sequence in multibyte variables	20
6.5 Telegram.....	20
6.6 Message format.....	20
6.6.1 Format of messages #1 to #32	20
6.6.2 Format of messages #33 to #255	21
6.7 Message specification.....	21
6.7.1 Reserved messages	21
6.7.2 Other messages	21
6.7.3 Message #1: Product description and overfill status (depot/station to truck).....	21
6.7.4 Message #2 Location and product details (depot/station to truck).....	23
6.7.5 Message #3 Multi product loading arm (depot to truck).....	25
6.7.6 Message #4 Tank properties (station to truck)	26
6.7.7 Message #5 Rack meter information (depot to truck).....	26
6.7.8 Message #6 Loading information (truck to depot).....	27
6.7.9 Message #7 Delivery information (truck to station)	28
6.7.10 Message #8 Station information (station to truck).....	29
6.7.11 Message #9 Acknowledge (depot to truck).....	30
6.7.12 Message #10 Return product information (truck to return station).....	30
6.7.13 Message #32 CRC 16.....	30
7 Tests.....	31

7.1	Type test	31
7.1.1	General	31
7.1.2	PID	31
7.1.3	PRD function test	34
7.1.4	Test results	36
7.2	Production test	36
7.2.1	General	36
7.2.2	PID static test	36
7.2.3	PID function test	36
7.2.4	PRD function test	36
7.2.5	Test results	36
8	Marking	37
9	Installation, operating and maintenance recommendations	37
Annex A	(informative) Manufacturer ID	38
Annex B	(normative) Calculation algorithm for CRC 16	39
Annex C	(informative) A-deviations	40
Annex D	(normative) Company code	41
D.1	Reason for the company code	41
D.2	Host of the list	41
D.3	Website	41
D.4	Rules	41
D.4.1	General	41
D.4.2	Preliminary registration	41
D.4.3	Access to "Oil Company code" table	41
D.4.4	Registration of a new company code	41
D.4.5	Automatic notification of changes	42
Bibliography	43

iTech STANDARD PREVIEW
(standards.itech.ai)

SIST EN 14116:2012+A1:2014

http://company-code.catalogue.standards/sist/76d28a8d-b082-461f-96a0-095b8adac8cb/sist-en-14116-2012a1-2014

095b8adac8cb/sist-en-14116-2012a1-2014

EN 14116:2012+A1:2014 (E)**Foreword**

This document (EN 14116:2012+A1:2014) has been prepared by Technical Committee CEN/TC 296 "Tanks for transport of dangerous goods", the secretariat of which is held by AFNOR.

This European Standard shall be given the status of a national standard, either by publication of an identical text or by endorsement, at the latest by March 2015, and conflicting national standards shall be withdrawn at the latest by March 2015.

Attention is drawn to the possibility that some of the elements of this document may be the subject of patent rights. CEN [and/or CENELEC] shall not be held responsible for identifying any or all such patent rights.

This document supersedes A1 EN 14116:2012 A1.

This document includes Amendment 1 approved by CEN on 2014-08-07.

The start and finish of text introduced or altered by amendment is indicated in the text by tags A1 A1.

A1 *deleted text* A1

According to the CEN/CENELEC Internal Regulations, the national standards organizations of the following countries are bound to implement this European Standard: Austria, Belgium, Bulgaria, Croatia, Cyprus, Czech Republic, Denmark, Estonia, Finland, Former Yugoslav Republic of Macedonia, France, Germany, Greece, Hungary, Iceland, Ireland, Italy, Latvia, Lithuania, Luxembourg, Malta, Netherlands, Norway, Poland, Portugal, Romania, Slovakia, Slovenia, Spain, Sweden, Switzerland, Turkey and the United Kingdom.

<https://standards.iteh.ai/catalog/standards/sist/76d28a8d-b082-4fdf-9fae-095b8adac8cb/sist-en-14116-2012a1-2014>

Introduction

Product recognition, the subject of this European Standard, is the digital interface that allows product data and/or other information to be transferred between transport tanks and other installations.

The European Committee for Standardisation (CEN) draws attention to the fact that it is claimed that compliance with this document may involve the use of a patent concerning hose communication methods given in Clause 4.

CEN takes no position concerning the evidence, validity and scope of this patent right.

The holder of this patent right has assured the CEN that he is willing to negotiate licences either free of charge or under reasonable and non-discriminatory terms and conditions with applicants throughout the world. In this respect, the statement of the holder of this patent right is registered with CEN. Information may be obtained from:

FMC Technologies

F.A. Sening GmbH

Regentstrasse 1

D-25474 Ellerbek

Germany

Phone: +49-4101 304-0

Fax: +49-4101-304-133 / 255

iTeh STANDARD PREVIEW
(standards.iteh.ai)

[SIST EN 14116:2012+A1:2014](https://standards.iteh.ai/catalog/standards/sist/76d28a8d-b082-4fdf-9fae-095b8adac8cb/sist-en-14116-2012a1-2014)

<https://standards.iteh.ai/catalog/standards/sist/76d28a8d-b082-4fdf-9fae-095b8adac8cb/sist-en-14116-2012a1-2014>

Attention is drawn to the possibility that some of the elements of this document may be the subject of patent rights other than those identified above. CEN shall not be held responsible for identifying any or all such patent rights.

CEN (<http://www.cen.eu/cen/WorkArea/IPR/Pages/default.aspx>) and CENELEC

(<http://www.cenelec.eu/membersandexperts/toolsandapplications/index.html>) maintain on-line lists of patents relevant to their standards. Users are encouraged to consult the lists for the most up to date information concerning patents.

EN 14116:2012+A1:2014 (E)**1 Scope**

This European Standard covers the digital interface at the product loading and/or discharge coupling which is used for the transfer of product related information and specifies the performance requirements, critical safety aspects and tests to provide compatibility of devices.

2 Normative references

The following documents, in whole or in part, are normatively referenced in this document and are indispensable for its application. For dated references, only the edition cited applies. For undated references, the latest edition of the referenced document (including any amendments) applies.

EN 13616:2004, *Overfill prevention devices for static tanks for liquid petroleum fuels*

EN 15208, *Tanks for transport of dangerous goods — Sealed parcel delivery systems — Working principles and interface specifications*

EN 60079-0, *Explosive atmospheres — Part 0: Equipment — General requirements (IEC 60079-0)*

EN 60079-11, *Explosive atmospheres — Part 11: Equipment protection by intrinsic safety "i" (IEC 60079-11)*

ISO 2859-1, *Sampling procedures for inspection by attributes — Part 1: Sampling schemes indexed by acceptance quality limit (AQL) for lot-by-lot inspection*

ISO 8601, *Data elements and interchange formats — Information interchange — Representation of dates and times*

SIST EN 14116:2012+A1:2014

<https://standards.iteh.ai/catalog/standards/sist/76d28a8d-b082-4fdf-9fae->

<https://standards.iteh.ai/catalog/standards/sist-en-14116-2012a1-2014>

3 Terms, definitions and abbreviations**3.1 Terms and definitions**

For the purposes of this document, the following terms and definitions apply.

3.1.1**message**

defined data set

3.1.2**telegram**

frame that contains at least one standardised message

3.1.3**maximum input voltage**

U_i

according to EN 60079-11

3.1.4**maximum output voltage**

U_o

according to EN 60079-11

3.1.5**maximum input current** I_i

according to EN 60079-11

3.1.6**maximum output current** I_0

according to EN 60079-11

3.1.7**maximum input power** P_i

according to EN 60079-11

3.1.8**maximum output power** P_0

according to EN 60079-11

3.1.9**maximum internal capacitance** C_i

according to EN 60079-11

3.1.10**maximum internal inductance** L_i

according to EN 60079-11

3.1.11**Multiple Product Identification Device****MultiPID**

electronic device emulating at least one PID, extended by the ability of bi-directional communication

3.2 Abbreviations

For the purposes of this document, the following abbreviations apply.

- ASCII American Standard Code for Information Interchange
- CPDP Comité Professionnel Du Pétrole
- ESD Electro-Static Discharge
- LSB Least Significant Bit
- MSB Most Significant Bit
- PID Product Identification Device
- PRD Product Recognition Device
- RON Research Octane Number

ITeH STANDARD PREVIEW
(standards.iteh.ai)

SIST EN 14116:2012+A1:2014
<https://standards.iteh.ai/catalog/standards/sist/76d28a8d-b082-4fdf-9fae-095b8adac8cb/sist-en-14116-2012a1-2014>

EN 14116:2012+A1:2014 (E)

4 Functions

Whenever a physical connection according to Figure 1 or Figure 2 is made, the digital interface enables the transfer of product recognition data to the transport tank. The purpose of this digital interface is to provide the data for the following types of applications:

- a) automatic product identification for each compartment or tank;
- b) cross over prevention;
- A1 c) overfill prevention (optional). A1

Bi-directionality may add the ability of communication between the stationary parts and the tank vehicle, e.g. the transfer of data of measured quantities in both directions.

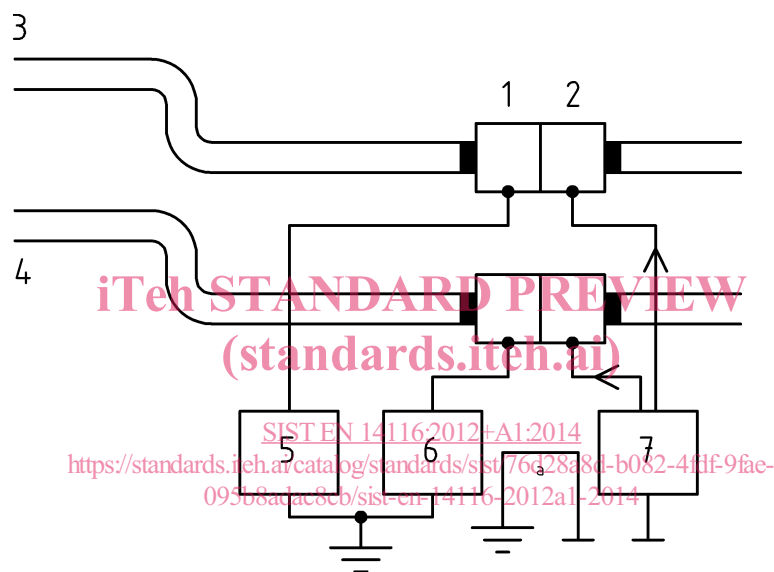

Key

- 1 pipework of loading arm with insulated coupling
- 2 pipework of transport tank with insulated coupling
- 3 vapour line
- 4 product line
- 5 PID, vapour
- 6 PID, product
- 7 PRD
- ^a required, if only one connection is established

Figure 1 — Loading

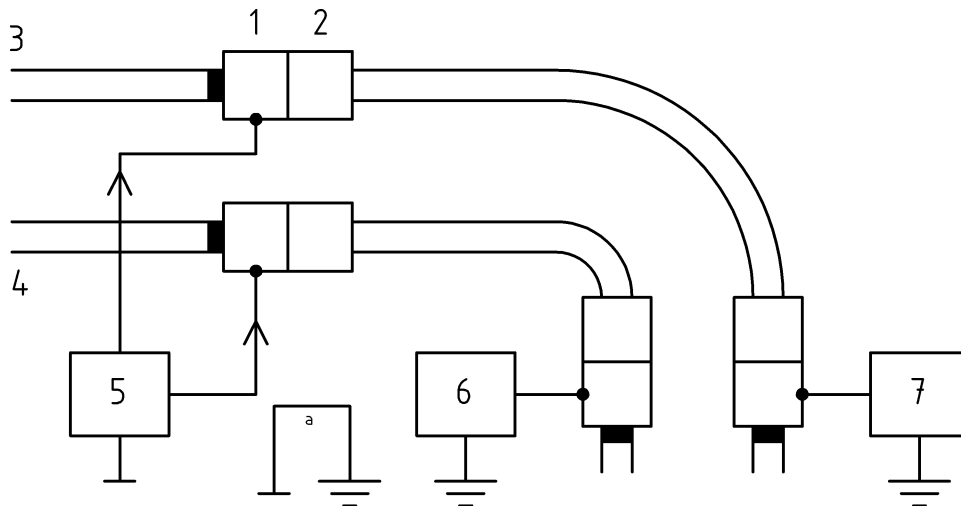
**Key**

- 1 pipework of transport tank with insulated coupling
- 2 conductive hoses^b and pipework of stationary tank with insulated couplings
- 3 vapour line
- 4 product line
- 5 PRD
- 6 PID, product
- 7 PID, vapour
- ^a required, if only one connection is established
- ^b if the discharge hoses are not conductive then the conductivity of these hoses shall be achieved by other means

iTeh STANDARD PREVIEW
(standards.iteh.ai)
<https://standards.iteh.ai/catalog/standards/sist/76d28a8d-b082-4fdf-9fae-095b8adac8f4>
SIST EN 14116:2012+A1:2014
Figure 2 – Unloading

PRD supplies an intrinsically safe circuit.

5 Design characteristics

5.1 General

The PRD shall be located on the transport tank. The PID shall be connected in series to a current loop with the PRD.

The PRD reads the PID by powering the PID through the hose or loading arm. The PID then sends its data by modulating the supply current, which is sensed by the PRD; see Figure 3.

The PID sends its data, using messages, which are numbered from 1 to 255.

The PID always transmits "message #1". By implementing more messages, it is possible to program the PID with other types of information; see 6.6.

Since the PID modulates the supply current, PIDs shall not be connected in parallel.

EN 14116:2012+A1:2014 (E)

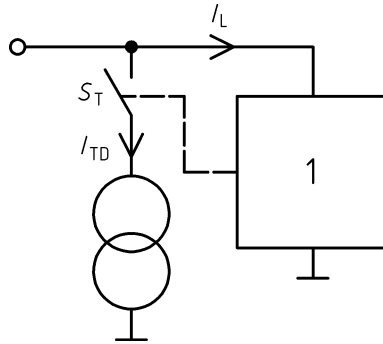
**Key****Components:**

- 1 electronic circuit
 S_T modulating switch
 I_L supply current without modulation
 I_{TD} supply current amplitude

Figure 3 — Basic circuit diagram of PID**5.2 Temperature range**

Unless otherwise specified, the operating temperature range shall be - 20 °C to + 50 °C.

Where the product recognition device is subjected to temperatures outside the specified temperature range, all applicable temperature values shall be extended. All other requirements shall remain unchanged.

5.3 Materials of construction

The manufacturer shall provide with the equipment a full material specification for those parts, which may come into contact with the substances according to Clause 1.

5.4 PRD

The PRD shall provide an intrinsically safe power supply with the values according to Table 1 to the PID.

Table 1 — DC electrical characteristics of PRD

Parameter	Unit	Min	Nom	Max	Ex-values ^a
Open-circuit voltage	V	11	12	15	$U_0 = 15$
Short-circuit current	mA	-	-	300	$I_0 = 300$
Output power	W	-	-	1,1	$P_0 = 1,1$
^a Maximum value to ensure compliance with EN 60079-11.					

Explosive protection shall be at least Ex ia IIA according to EN 60079-0 and EN 60079-11.

5.5 PID

5.5.1 General specification

Explosion protection shall be at least Ex ia IIA according to EN 60079-0 and EN 60079-11.

Table 2 — DC electrical characteristics of PID

Parameter	Symbol	Unit	Min	Nom	Max	Ex-values ^a
Supply voltage	U	V	6	12	15	$U_i = 15$
Supply current without modulation	I_L	mA	0	5	10	$I_i = 300$
Supply current at $U_+ < 3$ V	I_{OFF}	mA	-	-	5	-
Maximum input power	P_i	W	-	-	-	= 1,1
Maximum internal capacitance	C_i	nF	-	-	-	= 600
Maximum internal inductance	L_i	μ H	-	-	-	= 10

^a Maximum value to ensure compliance with EN 60079-11.

Table 3 — AC electrical characteristics of PID

Parameter	Symbol	Unit	Min	Nom	Max
Supply current amplitude	I_{TD}	mA	10	15	20
Clock rate	f_{TC}	Hz	4 800	4 880	4 960
Duty cycle	cd	%	40	50	60
Rise time of output signal	t_{Tr}	μ s	0	-	30
Fall time of output signal	t_{Tf}	μ s	0	-	30
Transmission delay after power on	t_{Tds}	ms	0	-	0,9

The timing diagram of PID is shown in Figure 4.