INTERNATIONAL STANDARD



1340

INTERNATIONAL ORGANIZATION FOR STANDARDIZATION • МЕЖДУНАРОДНАЯ ОРГАНИЗАЦИЯ ПО СТАНДАРТИЗАЦИИ • ORGANISATION INTERNATIONALE DE NORMALISATION

Cylindrical gears — Information to be given to the manufacturer by the purchaser in order to obtain the gear required

Engrenages cylindriques — Indications à fournir au tailleur d'engrenages par le client pour obtenir la denture désirée

First edition — 1976-08-01

iTeh STANDARD PREVIEW
(standards.iteh.ai)

[ISO 1340:1976](#)

<https://standards.iteh.ai/catalog/standards/sist/81e98405-13aa-496e-96cc-f7ea5b2c3e9/iso-1340-1976>

FOREWORD

ISO (the International Organization for Standardization) is a worldwide federation of national standards institutes (ISO Member Bodies). The work of developing International Standards is carried out through ISO Technical Committees. Every Member Body interested in a subject for which a Technical Committee has been set up has the right to be represented on that Committee. International organizations, governmental and non-governmental, in liaison with ISO, also take part in the work.

Draft International Standards adopted by the Technical Committees are circulated to the Member Bodies for approval before their acceptance as International Standards by the ISO Council.

Prior to 1972, the results of the work of the Technical Committees were published as ISO Recommendations; these documents are now in the process of being transformed into International Standards. As part of this process, Technical Committee ISO/TC 60 has reviewed ISO Recommendation R 1340 and found it technically suitable for transformation. International Standard ISO 1340 therefore replaces ISO Recommendation R 1340-1971 to which it is technically identical.

ISO Recommendation R 1340 was approved by the Member Bodies of the following countries :

Australia	India	Spain
Austria	Israel	Sweden
Belgium	Italy	Switzerland
Chile	Japan	Thailand
Czechoslovakia	Korea, Rep. of	Turkey
Egypt, Arab Rep. of	Netherlands	United Kingdom
Finland	New Zealand	U.S.S.R.
France	Paraguay	Yugoslavia
Germany	Poland	
Greece	South Africa, Rep. of	

The Member Bodies of the following countries expressed disapproval of the Recommendation on technical grounds :

Hungary*

* Subsequently, this Member Body approved the Recommendation.

No Member Body disapproved the transformation of ISO/R 1340 into an International Standard.

Cylindrical gears — Information to be given to the manufacturer by the purchaser in order to obtain the gear required

1 SCOPE AND FIELD OF APPLICATION

This International Standard specifies the information which should be stated on all cylindrical gear drawings. For each particular case they should be completed by such information as may be necessary or useful.

2 REFERENCES

ISO 53, *Cylindrical gears for general and heavy engineering — Basic rack.*

ISO/R 468, *Surface roughness.*

ISO 1302, *Technical drawings — Method of indicating surface texture on drawings.*

ISO 1328, *Parallel involute gears — ISO system of accuracy.*

ISO 2203, *Technical drawings — Conventional representation of gears.*

3 GENERAL DIMENSIONS AND CHARACTERISTICS TO BE INDICATED ON THE DRAWING

- Tip diameter and tolerance
- Facewidth
- Bore diameter and tolerance (or diameter and tolerance for the part of the shaft used for setting on the cutting machine)
- Locating face
- Surface finish of the tooth flank and, if applicable, of the root surface and of the fillets¹⁾

4 INFORMATION TO BE GIVEN IN A TABLE

The following information should preferably be given in the upper right-hand corner of the drawing :

- Module or diametral pitch (normal, in the case of helical gears)
- Number of teeth (for a sector : total number of teeth of the gear from which the sector is taken)

— Basic rack (give the number of the corresponding national standard or the pressure angle of 20°; if the basic rack differs from the standard rack, its characteristics should be specified, preferably by a figure)

— Value of the helix angle

— Helix direction (for double helix teeth, the helix direction should be shown by a symbol in accordance with ISO 2203)

— Reference diameter

— Addendum modification coefficient (to be expressed in unit module)

— Tooth thickness : basic value and upper and lower deviations (the basic value may be given in three different ways : Wildhaber measurement, measurement of constant chord, or measurement over pins or balls. For the first method, the number of teeth over which the measurement is to be carried out should be stated, and, for the third method, the diameter of the pins or balls)

— All useful information on tolerances (see ISO 1328)

— Centre distance of gear pair and tolerance

— Number of teeth and drawing number of the mating gear.

NOTE — The features outlined in clauses 3 and 4 are those which are considered essential. Any other useful information should be given to the gear manufacturer for the manufacture and inspection of the teeth as required by the particular form and characteristics of the gear.

In particular :

a) the necessity of ensuring firm location of the body of the gear on the cutting machine will require that the support and clamping faces (which should be perpendicular to the axis) and their permissible axial run-out should be indicated;

b) for shafted pinions and wheels the bores of which will not be used as reference for centring, it is necessary to specify the maximum radial run-out of the surface which serves as datum for checking the centring before commencement of cutting;

c) checking the accuracy of the teeth may necessitate the indication of certain characteristics (for example, the diameter of the base cylinder) or of special dimension and form tolerances for certain elements which serve as datum for measurement (for example, the tip cylinder).

1) Specifications concerning surface texture and the symbols used should be in accordance with ISO/R 468 and ISO 1302.

5 EXAMPLE

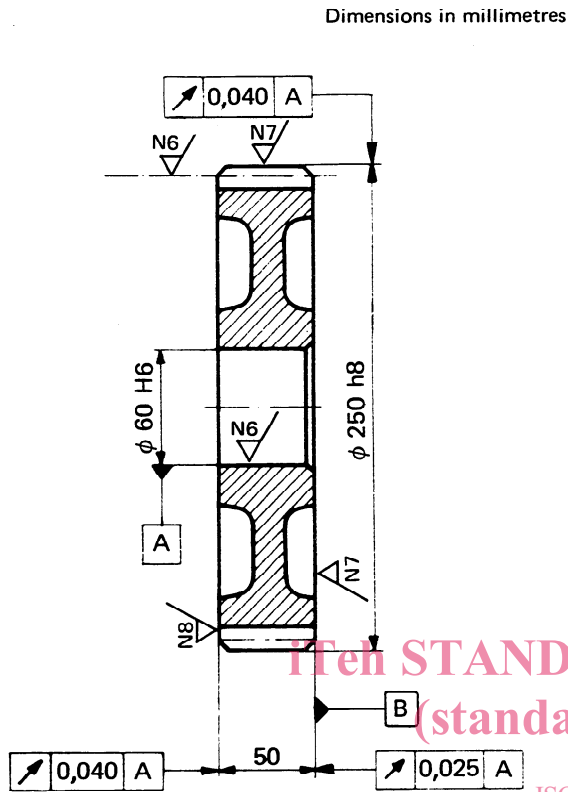

Characteristics of the teeth	
Module	5
Number of teeth	44
Basic rack	ISO 53 – 20°
Helix angle	23,5565° or 23° 33' 23,4"
Direction of helix angle	right hand
Reference diameter	240 mm
Addendum modification coefficient	0
Tooth thickness : base tangent length over k teeth ($k = 6$)	$85,13 \begin{smallmatrix} - 0,04 \\ - 0,06 \end{smallmatrix}$ mm
Quality class ¹⁾	6
Centre distance	$240 \pm 0,02$ mm
Mating gear	$z = 44$ drawing No. 12345
	2)
	2)
	2)

B : Locating face

1) According to ISO 1328, or to a corresponding national standard.
 2) Complementary information which may be necessary or useful.