

ETSI TS 137 340 V15.8.0 (2020-01)



Universal Mobile Telecommunications System (UMTS);

LTE;

5G;

NR;

Multi-connectivity;

Overall description;

Stage-2

(3GPP TS 37.340 version 15.8.0 Release 15)



Reference

RTS/TSGR-0237340vf80

Keywords

5G,LTE,UMTS

ETSI

650 Route des Lucioles
F-06921 Sophia Antipolis Cedex - FRANCE

Tel.: +33 4 92 94 42 00 Fax: +33 4 93 65 47 16

Siret N° 348 623 562 00017 - NAF 742 C
Association à but non lucratif enregistrée à la
Sous-Préfecture de Grasse (06) N° 7803/88

Important notice

The present document can be downloaded from:
<http://www.etsi.org/standards-search>

The present document may be made available in electronic versions and/or in print. The content of any electronic and/or print versions of the present document shall not be modified without the prior written authorization of ETSI. In case of any existing or perceived difference in contents between such versions and/or in print, the prevailing version of an ETSI deliverable is the one made publicly available in PDF format at www.etsi.org/deliver.

Users of the present document should be aware that the document may be subject to revision or change of status. Information on the current status of this and other ETSI documents is available at <https://portal.etsi.org/TB/ETSIDeliverableStatus.aspx>

If you find errors in the present document, please send your comment to one of the following services:
<https://portal.etsi.org/People/CommiteeSupportStaff.aspx>

Copyright Notification

No part may be reproduced or utilized in any form or by any means, electronic or mechanical, including photocopying and microfilm except as authorized by written permission of ETSI.

The content of the PDF version shall not be modified without the written authorization of ETSI.

The copyright and the foregoing restriction extend to reproduction in all media.

© ETSI 2020.

All rights reserved.

DECT™, **PLUGTESTS™**, **UMTS™** and the ETSI logo are trademarks of ETSI registered for the benefit of its Members. **3GPP™** and **LTE™** are trademarks of ETSI registered for the benefit of its Members and of the 3GPP Organizational Partners.

oneM2M™ logo is a trademark of ETSI registered for the benefit of its Members and of the oneM2M Partners.

GSM® and the GSM logo are trademarks registered and owned by the GSM Association.

Intellectual Property Rights

Essential patents

IPRs essential or potentially essential to normative deliverables may have been declared to ETSI. The information pertaining to these essential IPRs, if any, is publicly available for **ETSI members and non-members**, and can be found in ETSI SR 000 314: "*Intellectual Property Rights (IPRs); Essential, or potentially Essential, IPRs notified to ETSI in respect of ETSI standards*", which is available from the ETSI Secretariat. Latest updates are available on the ETSI Web server (<https://ipr.etsi.org/>).

Pursuant to the ETSI IPR Policy, no investigation, including IPR searches, has been carried out by ETSI. No guarantee can be given as to the existence of other IPRs not referenced in ETSI SR 000 314 (or the updates on the ETSI Web server) which are, or may be, or may become, essential to the present document.

Trademarks

The present document may include trademarks and/or tradenames which are asserted and/or registered by their owners. ETSI claims no ownership of these except for any which are indicated as being the property of ETSI, and conveys no right to use or reproduce any trademark and/or tradename. Mention of those trademarks in the present document does not constitute an endorsement by ETSI of products, services or organizations associated with those trademarks.

Legal Notice

This Technical Specification (TS) has been produced by ETSI 3rd Generation Partnership Project (3GPP).

The present document may refer to technical specifications or reports using their 3GPP identities. These shall be interpreted as being references to the corresponding ETSI deliverables.

The cross reference between 3GPP and ETSI identities can be found under <http://webapp.etsi.org/key/queryform.asp>.

Modal verbs terminology

In the present document "**shall**", "**shall not**", "**should**", "**should not**", "**may**", "**need not**", "**will**", "**will not**", "**can**" and "**cannot**" are to be interpreted as described in clause 3.2 of the [ETSI Drafting Rules](#) (Verbal forms for the expression of provisions).

"**must**" and "**must not**" are **NOT** allowed in ETSI deliverables except when used in direct citation.

Contents

Intellectual Property Rights	2
Legal Notice	2
Modal verbs terminology.....	2
Foreword.....	5
1 Scope	6
2 References	6
3 Definitions, symbols and abbreviations	7
3.1 Definitions	7
3.2 Abbreviations	8
4 Multi-Radio Dual Connectivity	8
4.1 General	8
4.1.1 Common MR-DC principles	8
4.1.2 MR-DC with the EPC	8
4.1.3 MR-DC with the 5GC	9
4.1.3.1 E-UTRA-NR Dual Connectivity	9
4.1.3.2 NR-E-UTRA Dual Connectivity	9
4.1.3.3 NR-NR Dual Connectivity	9
4.2 Radio Protocol Architecture	9
4.2.1 Control Plane	9
4.2.2 User Plane	10
4.3 Network interfaces	12
4.3.1 Control Plane	12
4.3.1.1 Common MR-DC principles	12
4.3.1.2 MR-DC with EPC	13
4.3.1.3 MR-DC with 5GC	13
4.3.2 User Plane	13
4.3.2.1 Common MR-DC principles	13
4.3.2.2 MR-DC with EPC	13
4.3.2.3 MR-DC with 5GC	13
5 Layer 1 related aspects	14
6 Layer 2 related aspects	14
6.1 MAC Sublayer	14
6.2 RLC Sublayer	14
6.3 PDCP Sublayer	14
6.4 SDAP Sublayer	15
7 RRC related aspects.....	15
7.1 System information handling	15
7.2 Measurements.....	15
7.3 UE capability coordination.....	16
7.4 Handling of combined MN/SN RRC messages.....	17
7.5 SRB3	17
7.6 Split SRB.....	18
7.7 SCG/MCG failure handling.....	18
7.8 UE identities	18
7.9 Inter-node Resource Coordination	18
8 Bearer handling aspects.....	19
8.1 QoS aspects	19
8.2 Bearer type selection	20
8.3 Bearer type change	21
8.4 User data forwarding	22
9 Security related aspects	22

10	Multi-Connectivity operation related aspects.....	22
10.1	General	22
10.2	Secondary Node Addition	23
10.2.1	EN-DC	23
10.2.2	MR-DC with 5GC.....	24
10.3	Secondary Node Modification (MN/SN initiated)	26
10.3.1	EN-DC	26
10.3.2	MR-DC with 5GC.....	30
10.4	Secondary Node Release (MN/SN initiated).....	34
10.4.1	EN-DC	34
10.4.2	MR-DC with 5GC.....	36
10.5	Secondary Node Change (MN/SN initiated)	38
10.5.1	EN-DC	38
10.5.2	MR-DC with 5GC.....	41
10.6	PSCell change	44
10.7	Inter-Master Node handover with/without Secondary Node change.....	44
10.7.1	EN-DC	44
10.7.2	MR-DC with 5GC.....	46
10.8	Master Node to eNB/gNB Change	48
10.8.1	EN-DC	48
10.8.2	MR-DC with 5GC.....	50
10.9	eNB/gNB to Master Node change	51
10.9.1	EN-DC	51
10.9.2	MR-DC with 5GC.....	52
10.10	RRC Transfer	53
10.10.1	EN-DC	53
10.10.2	MR-DC with 5GC.....	55
10.11	Secondary RAT data volume reporting	56
10.11.1	EN-DC	56
10.11.2	MR-DC with 5GC.....	57
10.12	Activity Notification.....	57
10.12.1	EN-DC	57
10.12.2	MR-DC with 5GC.....	58
10.13	Notification Control Indication	59
10.13.1	EN-DC	59
10.13.2	MR-DC with 5GC.....	60
10.14	PDU Session Split at UPF	60
10.14.1	PDU Session Split at UPF during PDU session resource setup.....	60
10.14.2	PDU Session Split at UPF during PDU session resource modify (5GC initiated).....	61
10.14.3	PDU Session Split at UPF (RAN initiated QoS flows offloading from MN to SN).....	61
11	Service related aspects.....	64
11.1	Roaming and Access Restrictions	64
11.2	Support of Network Sharing.....	64
12	X2/Xn Interface related aspects	64
13	Other aspects	64
13.1	Interference avoidance for in-device coexistence.....	64
Annex A (informative):	Layer 2 handling for bearer type change	65
Annex B (informative):	Supported MR-DC Handover Scenarios	67
Annex C (informative):	Change history	68
History		72

Foreword

This Technical Specification has been produced by the 3rd Generation Partnership Project (3GPP).

The contents of the present document are subject to continuing work within the TSG and may change following formal TSG approval. Should the TSG modify the contents of the present document, it will be re-released by the TSG with an identifying change of release date and an increase in version number as follows:

Version x.y.z

where:

- x the first digit:
 - 1 presented to TSG for information;
 - 2 presented to TSG for approval;
 - 3 or greater indicates TSG approved document under change control.
- Y the second digit is incremented for all changes of substance, i.e. technical enhancements, corrections, updates, etc.
- Z the third digit is incremented when editorial only changes have been incorporated in the document.

PREVIEW
iTech STANDARD
(standards.itih.ai)
Full standard:
<https://standards.itih.ai/catalog/standards/sist/95c7a47d-650a-4953-8502-f4c126ad1950/etsi-ts-137-340-v15.8.0-2020-01>

1 Scope

The present document provides an overview of the multi-connectivity operation using E-UTRA and NR radio access technologies. Details of the network and radio interface protocols are specified in companion specifications of the 36 and 38 series.

2 References

The following documents contain provisions which, through reference in this text, constitute provisions of the present document.

- References are either specific (identified by date of publication, edition number, version number, etc.) or non-specific.
- For a specific reference, subsequent revisions do not apply.
- For a non-specific reference, the latest version applies. In the case of a reference to a 3GPP document (including a GSM document), a non-specific reference implicitly refers to the latest version of that document *in the same Release as the present document*.

- [1] 3GPP TR 21.905: "Vocabulary for 3GPP Specifications".
- [2] 3GPP TS 36.300: "Evolved Universal Terrestrial Radio Access (E-UTRA) and Evolved Universal Terrestrial Radio Access Network (E-UTRAN); Overall description; Stage 2".
- [3] 3GPP TS 38.300: "NR; NR and NG-RAN Overall description; Stage 2".
- [4] 3GPP TS 38.331: "NR; Radio Resource Control (RRC) protocol specification".
- [5] 3GPP TS 38.423: "NG-RAN; Xn application protocol (XnAP)".
- [6] 3GPP TS 38.425: "NG-RAN; NR user plane protocol".
- [7] 3GPP TS 38.401: "NG-RAN; Architecture description".
- [8] 3GPP TS 38.133: "NG-RAN; Requirements for support of radio resource management".
- [9] 3GPP TS 36.423: "Evolved Universal Terrestrial Radio Access Network (E-UTRAN); X2 Application Protocol (X2AP)".
- [10] 3GPP TS 36.331: "Evolved Universal Terrestrial Radio Access (E-UTRA); Radio Resource Control (RRC); Protocol specification".
- [11] 3GPP TS 23.501: "System Architecture for the 5G System; Stage 2".
- [12] 3GPP TS 38.101-1: "User Equipment (UE) radio transmission and reception; Part 1: Range 1 Standalone".
- [13] 3GPP TS 38.101-2: "User Equipment (UE) radio transmission and reception; Part 2: Range 2 Standalone".
- [14] 3GPP TS 38.101-3: "User Equipment (UE) radio transmission and reception; Part 3: Range 1 and Range 2 Interworking operation with other radios".
- [15] 3GPP TS 36.323: "Evolved Universal Terrestrial Radio Access (E-UTRA); Packet Data Convergence Protocol (PDCP) specification".
- [16] 3GPP TS 38.323: "NR; Packet Data Convergence Protocol (PDCP) specification".

3 Definitions, symbols and abbreviations

3.1 Definitions

For the purposes of the present document, the terms and definitions given in TR 21.905 [1] and the following apply. A term defined in the present document takes precedence over the definition of the same term, if any, in TR 21.905 [1] and TS 36.300 [2].

En-gNB: node providing NR user plane and control plane protocol terminations towards the UE, and acting as Secondary Node in EN-DC.

Master Cell Group: in MR-DC, a group of serving cells associated with the Master Node, comprising of the SpCell (PCell) and optionally one or more SCells.

Master node: in MR-DC, the radio access node that provides the control plane connection to the core network. It may be a Master eNB (in EN-DC), a Master ng-eNB (in NGEN-DC) or a Master gNB (in NR-DC and NE-DC).

MCG bearer: in MR-DC, a radio bearer with an RLC bearer (or two RLC bearers, in case of CA packet duplication) only in the MCG.

MN terminated bearer: in MR-DC, a radio bearer for which PDCP is located in the MN.

MCG SRB: in MR-DC, a direct SRB between the MN and the UE.

Multi-Radio Dual Connectivity: Dual Connectivity between E-UTRA and NR nodes, or between two NR nodes.

Ng-eNB: as defined in TS 38.300 [3].

PCell: SpCell of a master cell group.

PSCell: SpCell of a secondary cell group.

RLC bearer: RLC and MAC logical channel configuration of a radio bearer in one cell group.

Secondary Cell Group: in MR-DC, a group of serving cells associated with the Secondary Node, comprising of the SpCell (PSCell) and optionally one or more SCells.

Secondary node: in MR-DC, the radio access node, with no control plane connection to the core network, providing additional resources to the UE. It may be an en-gNB (in EN-DC), a Secondary ng-eNB (in NE-DC) or a Secondary gNB (in NR-DC and NGEN-DC).

SCG bearer: in MR-DC, a radio bearer with an RLC bearer (or two RLC bearers, in case of CA packet duplication) only in the SCG.

SN terminated bearer: in MR-DC, a radio bearer for which PDCP is located in the SN.

SpCell: primary cell of a master or secondary cell group.

SRB3: in EN-DC, NGEN-DC and NR-DC, a direct SRB between the SN and the UE.

Split bearer: in MR-DC, a radio bearer with RLC bearers both in MCG and SCG.

Split PDU Session (or PDU Session split): a PDU Session whose QoS Flows are served by more than one SDAP entities in the NG-RAN.

Split SRB: in MR-DC, a SRB between the MN and the UE with RLC bearers both in MCG and SCG.

User plane resource configuration: in MR-DC with 5GC, encompasses radio network resources and radio access resources related to either one or more PDU sessions, one or more QoS flows, one or more DRBs, or any combination thereof.

3.2 Abbreviations

For the purposes of the present document, the abbreviations given in TR 21.905 [1] and the following apply. An abbreviation defined in the present document takes precedence over the definition of the same abbreviation, if any, in TR 21.905 [1] and TS 36.300 [2].

DC	Intra-E-UTRA Dual Connectivity
EN-DC	E-UTRA-NR Dual Connectivity
MCG	Master Cell Group
MN	Master Node
MR-DC	Multi-Radio Dual Connectivity
NE-DC	NR-E-UTRA Dual Connectivity
NGEN-DC	NG-RAN E-UTRA-NR Dual Connectivity
NR-DC	NR-NR Dual Connectivity
SCG	Secondary Cell Group
SMTC	SS/PBCH block Measurement Timing Configuration
SN	Secondary Node

4 Multi-Radio Dual Connectivity

4.1 General

4.1.1 Common MR-DC principles

Multi-Radio Dual Connectivity (MR-DC) is a generalization of the Intra-E-UTRA Dual Connectivity (DC) described in TS 36.300 [2], where a multiple Rx/Tx capable UE may be configured to utilise resources provided by two different nodes connected via non-ideal backhaul, one providing NR access and the other one providing either E-UTRA or NR access. One node acts as the MN and the other as the SN. The MN and SN are connected via a network interface and at least the MN is connected to the core network.

NOTE 1: MR-DC is designed based on the assumption of non-ideal backhaul between the different nodes but can also be used in case of ideal backhaul.

NOTE 2: All MR-DC normative text and procedures in this version of the specification show the aggregated node case. The details about non-aggregated node for MR-DC operation are described in TS 38.401 [7].

4.1.2 MR-DC with the EPC

E-UTRAN supports MR-DC via E-UTRA-NR Dual Connectivity (EN-DC), in which a UE is connected to one eNB that acts as a MN and one en-gNB that acts as a SN. The eNB is connected to the EPC via the S1 interface and to the en-gNB via the X2 interface. The en-gNB might also be connected to the EPC via the S1-U interface and other en-gNBs via the X2-U interface.

The EN-DC architecture is illustrated in Figure 4.1.2-1 below.

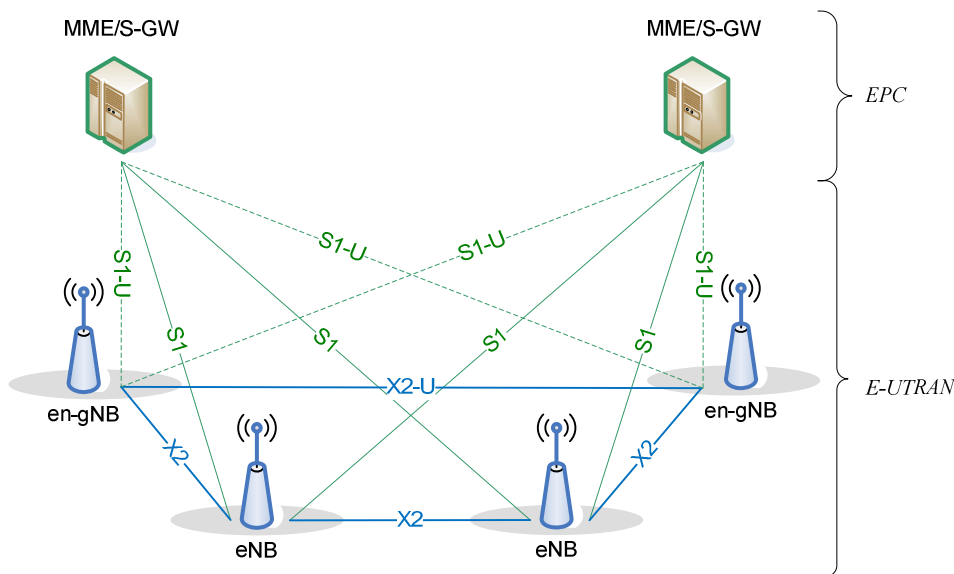

Figure 4.1.2-1: EN-DC Overall Architecture

4.1.3 MR-DC with the 5GC

4.1.3.1 E-UTRA-NR Dual Connectivity

NG-RAN supports NG-RAN E-UTRA-NR Dual Connectivity (NGEN-DC), in which a UE is connected to one ng-eNB that acts as a MN and one gNB that acts as a SN.

4.1.3.2 NR-E-UTRA Dual Connectivity

NG-RAN supports NR-E-UTRA Dual Connectivity (NE-DC), in which a UE is connected to one gNB that acts as a MN and one ng-eNB that acts as a SN.

4.1.3.3 NR-NR Dual Connectivity

NG-RAN supports NR-NR Dual Connectivity (NR-DC), in which a UE is connected to one gNB that acts as a MN and another gNB that acts as a SN. In addition, NR-DC can also be used when a UE is connected to two gNB-DUs, one serving the MCG and the other serving the SCG, connected to the same gNB-CU, acting both as a MN and as a SN.

4.2 Radio Protocol Architecture

4.2.1 Control Plane

In MR-DC, the UE has a single RRC state, based on the MN RRC and a single C-plane connection towards the Core Network. Figure 4.2.1-1 illustrates the Control plane architecture for MR-DC. Each radio node has its own RRC entity (E-UTRA version if the node is an eNB or NR version if the node is a gNB) which can generate RRC PDUs to be sent to the UE.

RRC PDUs generated by the SN can be transported via the MN to the UE. The MN always sends the initial SN RRC configuration via MCG SRB (SRB1), but subsequent reconfigurations may be transported via MN or SN. When transporting RRC PDU from the SN, the MN does not modify the UE configuration provided by the SN.

In E-UTRA connected to EPC, at initial connection establishment SRB1 uses E-UTRA PDCP. If the UE supports EN-DC, regardless whether EN-DC is configured or not, after initial connection establishment, MCG SRBs (SRB1 and SRB2) can be configured by the network to use either E-UTRA PDCP or NR PDCP (either SRB1 and SRB2 are both configured with E-UTRA PDCP, or they are both configured with NR PDCP). Change from E-UTRA PDCP to NR PDCP (or vice-versa) is supported via a handover procedure (reconfiguration with mobility) or, for the initial change of SRB1 from E-UTRA PDCP to NR PDCP, with a reconfiguration without mobility before the initial security activation.

If the SN is a gNB (i.e. for EN-DC, NGEN-DC and NR-DC), the UE can be configured to establish a SRB with the SN (SRB3) to enable RRC PDUs for the SN to be sent directly between the UE and the SN. RRC PDUs for the SN can only be transported directly to the UE for SN RRC reconfiguration not requiring any coordination with the MN. Measurement reporting for mobility within the SN can be done directly from the UE to the SN if SRB3 is configured.

Split SRB is supported for all MR-DC options, allowing duplication of RRC PDUs generated by the MN, via the direct path and via the SN. Split SRB uses NR PDCP. This version of the specification does not support the duplication of RRC PDUs generated by the SN via the MN and SN paths.

In EN-DC, the SCG configuration is kept in the UE during suspension. The UE releases the SCG configuration (but not the radio bearer configuration) during resumption initiation.

In MR-DC with 5GC, the UE stores the PDCP/SDAP configuration when moving to RRC Inactive but it releases the SCG configuration.

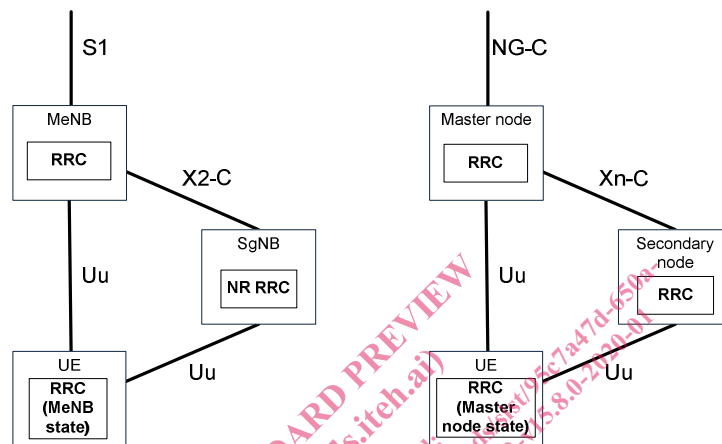

Figure 4.2.1-1: Control plane architecture for EN-DC (left) and MR-DC with 5GC (right).

4.2.2 User Plane

In MR-DC, from a UE perspective, three bearer types exist: MCG bearer, SCG bearer and split bearer. These three bearer types are depicted in Figure 4.2.2-1 for MR-DC with EPC (EN-DC) and in Figure 4.2.2-2 for MR-DC with 5GC (NGEN-DC, NE-DC and NR-DC).

In E-UTRA connected to EPC, if the UE supports EN-DC, regardless whether EN-DC is configured or not, the network can configure either E-UTRA PDCP or NR PDCP for MN terminated MCG bearers while NR PDCP is always used for all other bearers.

In MR-DC with 5GC, NR PDCP is always used for all bearer types. In NGEN-DC, E-UTRA RLC/MAC is used in the MN while NR RLC/MAC is used in the SN. In NE-DC, NR RLC/MAC is used in the MN while E-UTRA RLC/MAC is used in the SN. In NR-DC, NR RLC/MAC is used in both MN and SN.

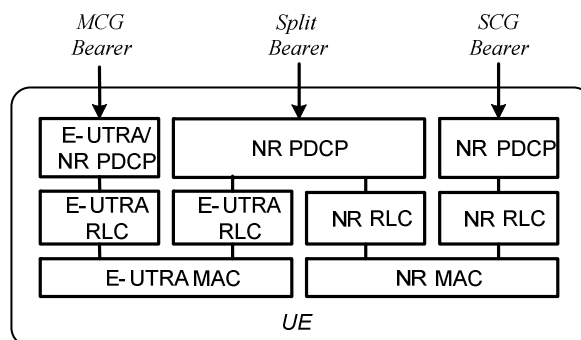

Figure 4.2.2-1: Radio Protocol Architecture for MCG, SCG and split bearers from a UE perspective in MR-DC with EPC (EN-DC)

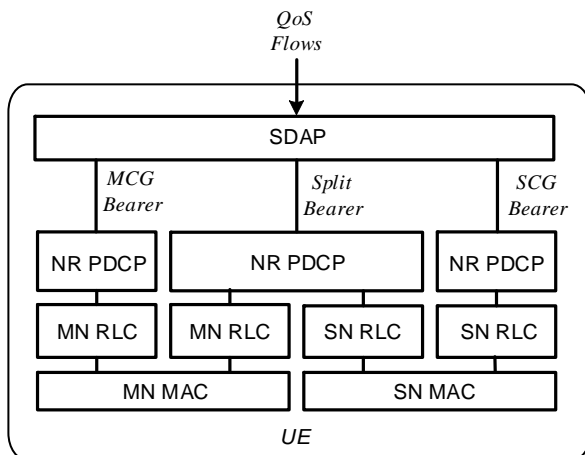

Figure 4.2.2-2: Radio Protocol Architecture for MCG, SCG and split bearers from a UE perspective in MR-DC with 5G (NGEN-DC, NE-DC and NR-DC).

From a network perspective, each bearer (MCG, SCG and split bearer) can be terminated either in MN or in SN. Network side protocol termination options are shown in Figure 4.2.2-3 for MR-DC with EPC (EN-DC) and in Figure 4.2.2-4 for MR-DC with 5G (NGEN-DC, NE-DC and NR-DC).

NOTE 1: Even if only SCG bearers are configured for a UE, for SRB1 and SRB2 the logical channels are always configured at least in the MCG, i.e. this is still an MR-DC configuration and a PCell always exists.

NOTE 2: If only MCG bearers are configured for a UE, i.e. there is no SCG, this is still considered an MR-DC configuration, as long as at least one of the bearers is terminated in the SN.

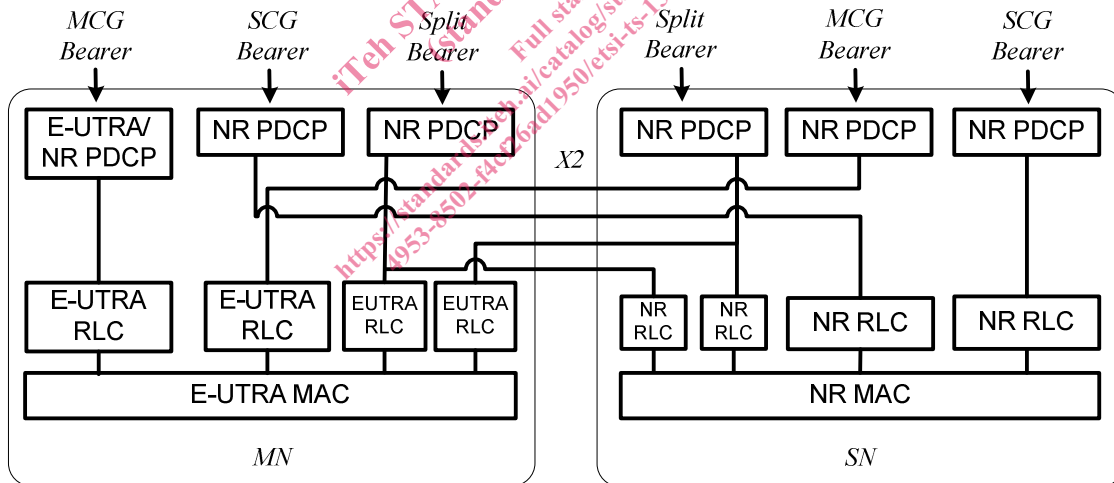

Figure 4.2.2-3: Network side protocol termination options for MCG, SCG and split bearers in MR-DC with EPC (EN-DC).

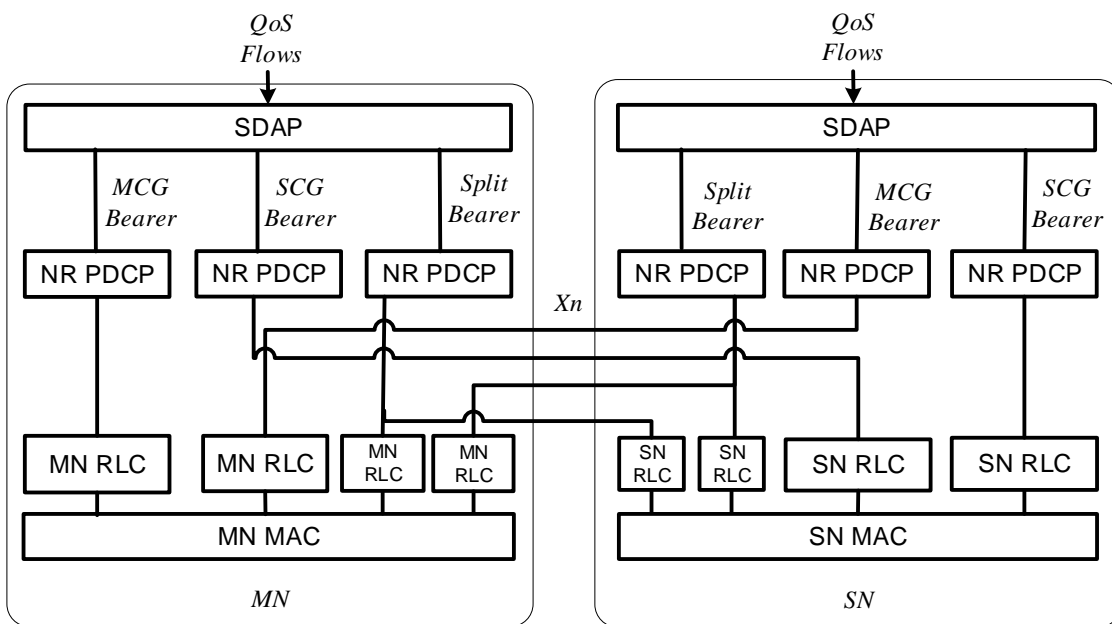

Figure 4.2.2-4: Network side protocol termination options for MCG, SCG and split bearers in MR-DC with 5G (NGEN-DC, NE-DC and NR-DC).

4.3 Network interfaces

4.3.1 Control Plane

4.3.1.1 Common MR-DC principles

In MR-DC, there is an interface between the MN and the SN for control plane signalling and coordination. For each MR-DC UE, there is also one control plane connection between the MN and a corresponding CN entity. The MN and the SN involved in MR-DC for a certain UE control their radio resources and are primarily responsible for allocating radio resources of their cells.

Figure 4.3.1.1-1 shows C-plane connectivity of MN and SN involved in MR-DC for a certain UE.

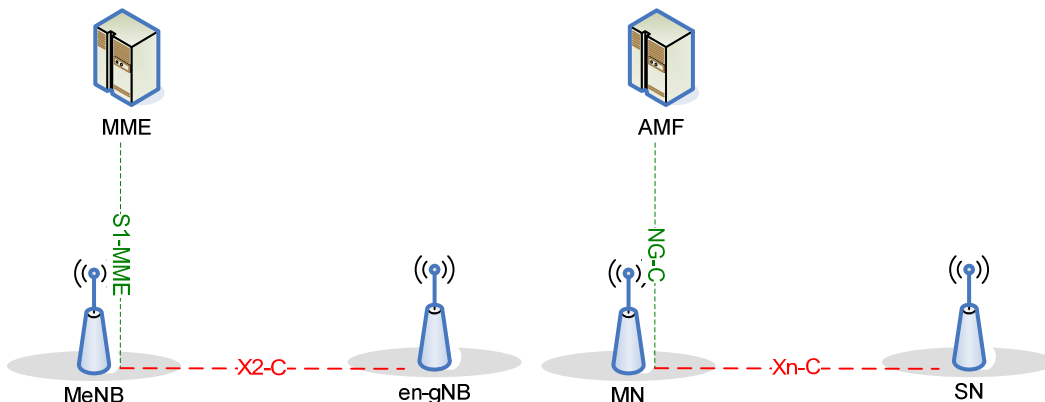

Figure 4.3.1.1-1: C-Plane connectivity for EN-DC (left) and MR-DC with 5G (right).