



Designation: ~~F1939-07~~ Designation: F 1939 - 08

# Standard Test Method for Radiant Heat Resistance of Flame Resistant Clothing Materials with Continuous Heating<sup>1</sup>

This standard is issued under the fixed designation F 1939; the number immediately following the designation indicates the year of original adoption or, in the case of revision, the year of last revision. A number in parentheses indicates the year of last reapproval. A superscript epsilon ( $\epsilon$ ) indicates an editorial change since the last revision or reapproval.

## 1. Scope

1.1 This test method rates the non-steady state thermal resistance or insulating characteristics of flame resistant clothing materials subjected to a continuous, standardized radiant heat exposure.

1.1.1 This test method is not applicable to clothing materials that are not flame resistant.

NOTE 1—The determination of a clothing material's flame resistance shall be made prior to testing and done in accordance with the applicable performance standard, specification standard, or both, for the clothing material's end-use.

1.1.2 This test method does not predict skin burn injury from the standardized radiant heat exposure as it does not account for the thermal energy contained in the test specimen after the exposure has ceased.

NOTE 2—See Appendix X4 for additional information regarding this test method and predicted skin burn injury.

1.2 This test method is used to measure and describe the response of materials, products, or assemblies to heat under controlled conditions, but does not by itself incorporate all factors required for fire hazard or fire risk assessment of the materials, products, or assemblies under actual fire conditions.

1.3 The values stated in SI units are to be regarded as standard. The values given in brackets are mathematical conversions to inch-pound or other units that are commonly used for thermal testing.

1.4 *This standard does not purport to address all of the safety concerns, if any, associated with its use. It is the responsibility of the user of this standard to establish appropriate safety and health practices and determine the applicability of regulatory limitations prior to use.*

## 2. Referenced Documents

2.1 *ASTM Standards:*<sup>2</sup>

D 123 Terminology Relating to Textiles

D 1776 Practice for Conditioning and Testing Textiles

D 1777 Test Method for Thickness of Textile Materials

D 3776 Test Methods for Mass Per Unit Area (Weight) of Fabric

E 457 Test Method for Measuring Heat-Transfer Rate Using a Thermal Capacitance (Slug) Calorimeter

F 1494 Terminology Relating to Protective Clothing

2.2 *ASTM Special Technical Publication: ASTM Report, "ASTM Research Program on Electric Arc Test Method Developments to Evaluate Protective Clothing Fabric; ASTM F18.65.01 Testing Group Report on Arc Testing Analysis of the F1959 Standard Test Method-Phase I"*

ASTM Manual 12 Manual on the Use of Thermocouples in Temperature Measurement

## 3. Terminology

3.1 *Definitions:*

3.1.1 *break-open, n*—in testing thermal protective materials, a material response evidenced by the formation of a hole in the test specimen during the thermal exposure that may result in the exposure energy in direct contact with the heat sensor.

3.1.2 *charring, n*—the formation of a carbonaceous residue as the result of pyrolysis or incomplete combustion.

3.1.3 *dripping, n*—a material response evidenced by flowing of the polymer.

<sup>1</sup> This test method is under the jurisdiction of ASTM Committee F23 on Personal Protective Clothing and Equipment and is the direct responsibility of Subcommittee F23.80 on Flame and Thermal.

Current edition approved Oct. Feb. 1, 2007-2008. Published November 2007-February 2008. Originally approved in 1999. Last previous edition approved in 1999-2007 as F1939-99a-F1939-07.

<sup>2</sup> For referenced ASTM standards, visit the ASTM website, www.astm.org, or contact ASTM Customer Service at service@astm.org. For *Annual Book of ASTM Standards* volume information, refer to the standard's Document Summary page on the ASTM website.

3.1.4 *embrittlement, n*—the formation of a brittle residue as a result of pyrolysis or incomplete combustion.

3.1.5 *heat flux, n*—the thermal intensity indicated by the amount of energy transmitted divided by area and time; kW/m<sup>2</sup>[cal/cm<sup>2</sup>s].

3.1.6 *ignition, n*—the initiation of combustion.

3.1.7 *melting, n*—a material response evidenced by softening of the polymer.

3.1.8 *non-steady state thermal resistance, n*—in testing of thermal protective materials, a quantity expressed as the time-dependent difference between the incident and exiting thermal energy values normal to and across two defined parallel surfaces of an exposed thermal insulative material.

3.1.9 *radiant heat resistance (RHR), n*—in testing of thermal protective materials, the cumulative amount of thermal exposure energy identified by the intersection of the measured time-dependent heat transfer response through the subject material to a time-dependent, empirical performance curve, expressed as a rating or value; kJ/m<sup>2</sup>[cal/cm<sup>2</sup>].

3.1.10 *response to heat exposure, n*—in testing the thermal resistance of thermal protective materials, the observable response of the material to the energy exposure as indicated by break-open, melting, dripping, charring, embrittlement, shrinkage, sticking, and ignition.

3.1.11 *shrinkage, n*—a decrease in one or more dimensions of an object or material.

3.1.12 *sticking, n*—a material response evidenced by softening and adherence of the material to the surface of itself or another material.

3.1.13 For the definitions of protective clothing terms used in this method, refer to Terminology F 1494, and for other textile terms used in this method, refer to Terminology D 123.

#### 4. Summary of Test Method

4.1 A vertically positioned test specimen is exposed to a radiant heat source with an exposure heat flux of either (a) 21 kW/m<sup>2</sup>[0.5 cal/cm<sup>2</sup>s] or (b) 84 kW/m<sup>2</sup>[2 cal/cm<sup>2</sup>s].

NOTE 3—Other exposure heat flux values are allowed. The test facility shall verify the stability of the exposure level over the material's exposure time interval (used to determine the radiant heat resistance value) and include this in the test results report.

4.2 The transfer of heat through the test specimen is measured using a copper slug calorimeter. The change in temperature versus time is used, along with the known thermo-physical properties of copper to determine the respective thermal energy delivered.

4.3 A Radiant Heat Resistance rating of the test specimen is determined as the intersection of the time-dependent cumulative radiant heat response as measured by the calorimeter to a time-dependent, empirical performance curve identified in 10.9.

4.4 Subjective observations of the thermal response of tested specimens are optionally noted.

#### 5. Significance and Use

5.1 This test method is intended for the determination of the radiant heat resistance value of a material, a combination of materials, or a comparison of different materials used in flame resistant clothing for workers exposed to radiant thermal hazards.

5.2 This test method evaluates a material's heat transfer properties when exposed to a continuous and constant radiant heat source. Air movement at the face of the specimen and around the calorimeter can affect the measured heat transferred due to forced convective heat losses. Minimizing the air movement around the specimen and test apparatus will aid in the repeatability of the results.

5.3 This test method maintains the specimen in a static, vertical position and does not involve movement, except that resulting from the exposure.

5.4 This test method specifies two standard sets of exposure conditions: 21 kW/m<sup>2</sup>[0.5 cal/cm<sup>2</sup>s] and 84 kW/m<sup>2</sup>[2.0 cal/cm<sup>2</sup>s]. Either can be used.

5.4.1 If a different set of exposure conditions is used, it is likely that different results will be obtained.

5.4.2 The optional use of other conditions representative of the expected hazard, in addition to the standard set of exposure conditions, is permitted. However, the exposure conditions used must be reported with the results along with a determination of the exposure energy level stability.

5.5 This test method does not predict skin burn injury from the standardized radiant heat exposure.

NOTE 4—See Appendix X4 for additional information regarding this test method and predicted skin burn injury.

#### 6. Apparatus and Materials

6.1 *General Arrangement*—The apparatus consists of a vertically oriented radiant heat source, specimen holder assembly, protective shutter, sensor assembly, and data acquisition/analysis system. The general arrangement of the radiant heat source, specimen holder, and protective shutter of a suitable apparatus is shown in Fig. 1.

6.1.1 *Radiant Heat Source*—A suitable, vertically oriented radiant heat source is shown in Fig. 1. It consists of a bank of five, 500 W infrared, tubular, translucent quartz lamps having a 127-mm [5.0-in.] lighted length and a mean overall length of 222 mm [8 ¾ in.]. The lamps are mounted on 9.5 ± 0.4-mm [⅜ ± 1/64-in.] centers so that the lamp surfaces are approximately 0.4-mm [1/64-in.] apart. The bank or array of lamps are mounted and centered behind a 63.5 by 140-mm [2½ by 5 ½-in.] cut-out that is positioned in the center of a 12.7-mm [½-in.] thick, 86-mm [3 ⅜-in. wide, by 292-mm [11½-in.] long high temperature insulating

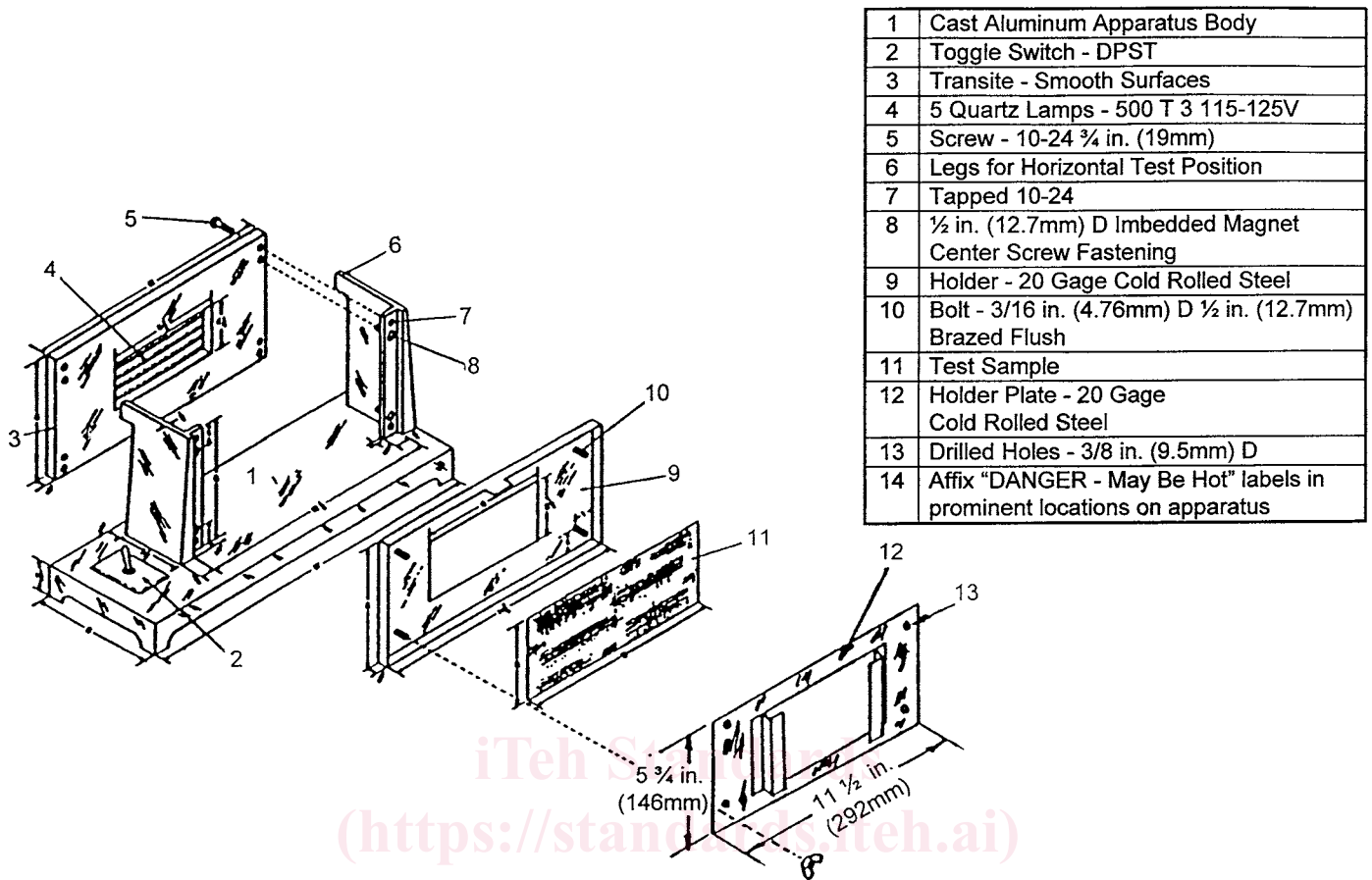

FIG. 1 General Expanded View of a Compliant Radiant Resistance Performance Test Apparatus (See Figures 2, 3, and 4 for specific item details.)

board as shown in Fig. 2. The quartz lamps shall be heated electrically, and the power input controlled by means of a rheostat or variable power supply having a capacity of at least 25A.

6.1.1.1 Setting and monitoring the voltmeter readout on a voltage-controlled variable power supply is one method to calibrate and monitor the exposure level during the testing on a system so equipped. A voltmeter, accurate to  $\pm 1$  V, is typically installed with the appropriate load circuit to indicate lamp operating power.

6.1.1.2 Any covers or guards installed on the quartz lamp assembly shall be designed such that any convective energy generated is not allowed to impinge on the sample specimen (vertical, unimpeded ventilation is required.)

NOTE 5—Radiant measurement systems designed with closed lamp assembly covers and covers with minimal ventilation have been found to exhibit large measurement biases in round robin testing.

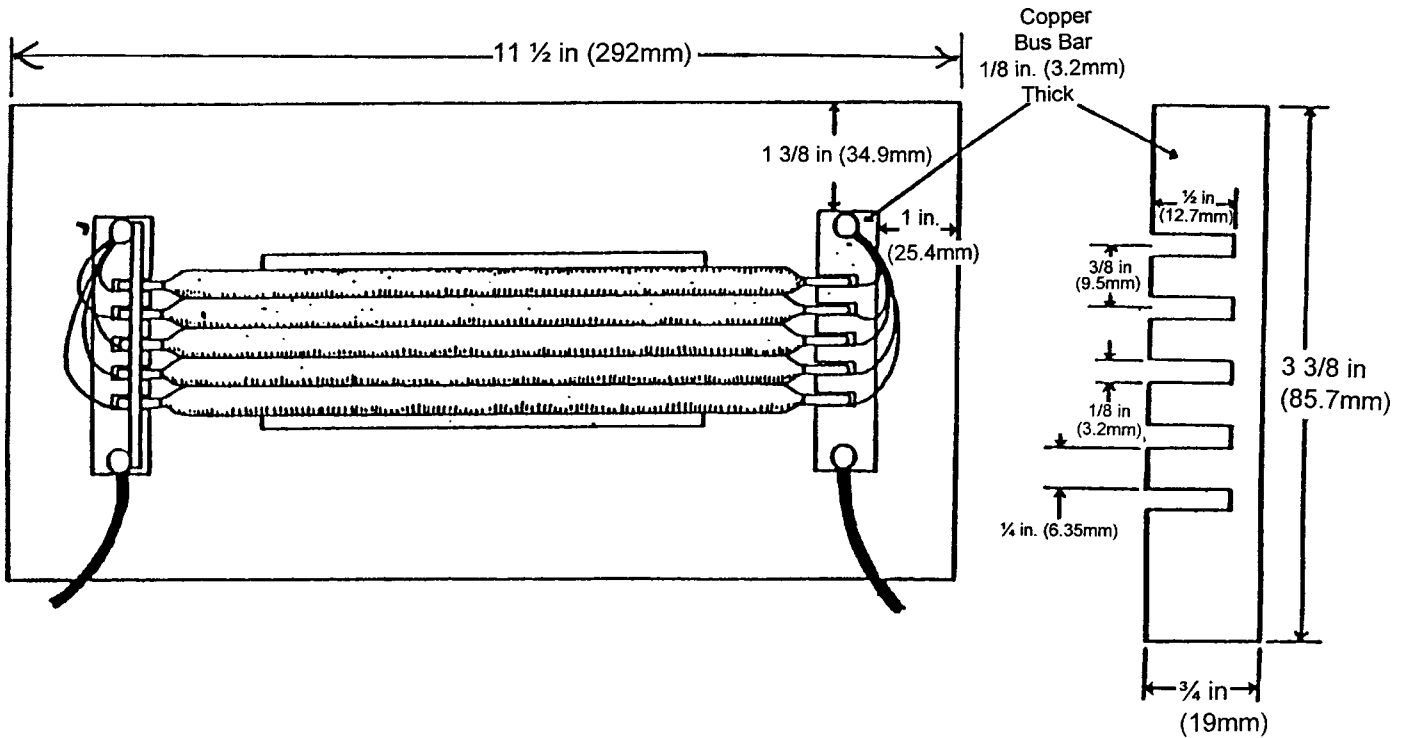

FIG. 2 Detailed View of Position of Quartz Lamps on Thermal Insulating Board

NOTE 6—Transite monolithic, non-asbestos fiber cement board<sup>3, 4</sup> has been found to be effective as a high temperature insulating board.

6.1.2 *Specimen Holder Assembly*—A specimen holder and holder plate with a 64 by 152-mm [2 1/2 by 6-in.] center cut-out is positioned so that the distance from the nearest lamp surface to the test specimen is  $25.4 \pm 0.4$  mm [ $1.0 \pm 1/64$  in.]. The rear holder plate thickness is  $0.9 \pm 0.05$  mm [ $0.036 \pm 0.002$  in.] and includes a bracket to hold the copper calorimeter sensor assembly. This rear plate holds the specimen in place so that it covers the complete cutout section (see typical designs shown in Figs. 3 and 4). Several specimen holders are recommended to facilitate testing.

ASTM F1939-08

<sup>3</sup> The sole source of supply of this type of product known to the committee at this time is BNZ Materials, Inc., 6901 South Pierce Street, Suite 260, Littleton, CO 80128, Ph: 800-999-0890.

<sup>4</sup> If you are aware of alternative suppliers, please provide this information to ASTM International Headquarters. Your comments will receive careful consideration at a meeting of the responsible technical committee, which you may attend.

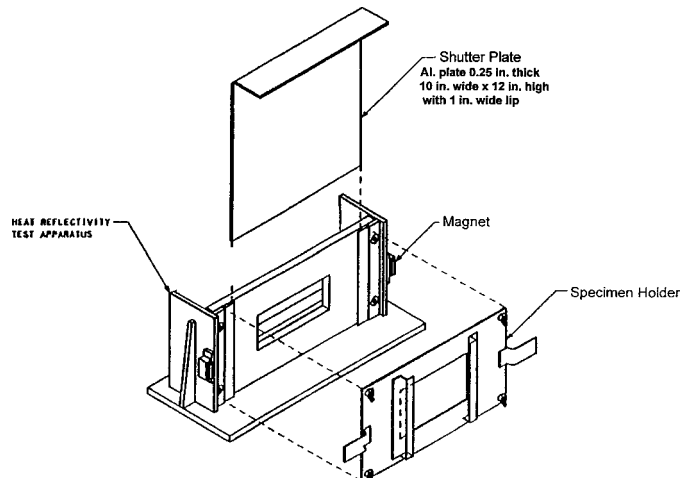

FIG. 3 Detailed View of a Compliant Radiant Protective Performance Test Apparatus Showing Holder with Window, Manual Shutter Plate, and Specimen Holder with Calorimeter Brackets. (A magnet/tab arrangement is shown as an equipment design option to hold the specimen holder to the assembly.)

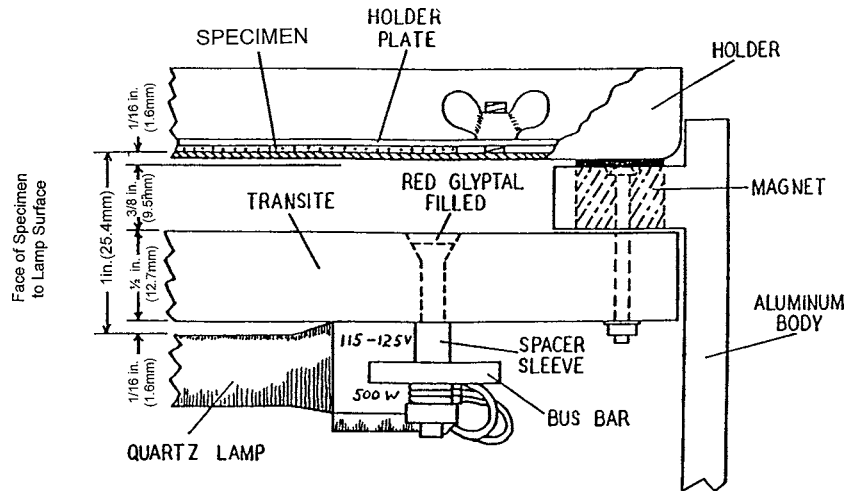

FIG. 4 Sample Position Example—Top View Enlargement

NOTE 7—The copper calorimeter sensor assembly holder plate bracket is constructed such that the calorimeter assembly is in a reproducible fixed vertical position when installed and is held flush and rigidly against the rear holder plate.

6.1.3 *Protective Shutter*—A protective shutter, as shown in Fig. 3, is placed between the radiant energy source and the specimen. The protective shutter blocks the radiant energy just prior to the exposure of a specimen. Manual or mechanically operated shutter designs are allowed with and without water-cooling.

6.1.4 *Rheostat or Variable Power Supply*—A standard laboratory rheostat or appropriate power supply with a capacity of at least 25 A, which is capable of controlling the output intensity of the tubes over the range specified in 4.1.

6.1.5 *Sensor*—The radiant heat sensor is a  $4 \pm 0.05$  cm diameter circular copper slug calorimeter constructed from electrical grade copper with a mass of  $18 \pm 0.05$  g (prior to drilling) with a single iron-constantan (ANSI Type J) thermocouple wire bead (0.254 mm wire diameter or finer—equivalent to 30 AWG) installed as identified in 6.1.5.2 and shown in Fig. 5 (see Test Method E 457 for information regarding slug calorimeters). The sensor holder shall be constructed from non-conductive heat resistant material with a thermal conductivity value of  $\leq 0.15$  W/m·K, high temperature stability, and resistance to thermal shock. The board shall be nominally 1.3 cm [0.5 in.] or greater in thickness and meet the specimen holder assembly requirements of 6.1.2. The sensor is held into the recess of the board using three straight pins, trimmed to a nominal length of 5 mm, by placing them equidistant around the edge of the sensor so that the heads of the pins hold the sensor flush to the surface.

6.1.5.1 Paint the exposed surface of the copper slug calorimeters with a thin coating of a flat black high temperature spray paint with an absorptivity of 0.9 or greater.<sup>4,5</sup> The painted sensor must be dried and cured, in accordance with the manufacturer's

<sup>5</sup> Zynolyte #635 has been found suitable. The sole source of supply of Zynolyte #635 known to the committee at this time is Aervoe Industries, 1198 Mark Circle Gardnerville, NV 89410, Ph: 800-227-0196.

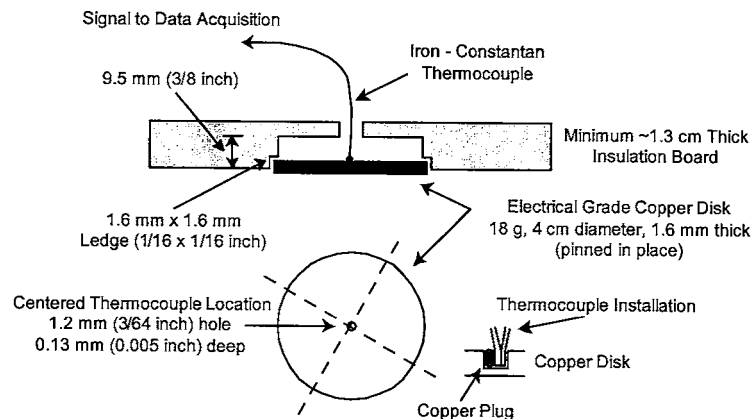

NOTE 1—Secure the copper disk into the supporting insulation board with 3 or 4 sewing pins cut to 9.5 mm (0.375 in.) in length (positioned around the periphery so that the sewing pin heads hold the disk into the board).

FIG. 5 Radiant Heat Resistance Test Sensor (Copper Calorimeter Mounted in Insulation Block) Showing Mechanical Bonding of Thermocouple to Copper Disk



instructions, before use and present a uniformly applied coating (no visual thick spots or surface irregularities). In the absence of manufacturer's instructions, an external heat source (for example, an external heat lamp), shall be used to completely drive off any remaining organic carriers in a freshly painted surface before use.

NOTE 8—Absorptivity of painted calorimeters is discussed in the ASTM Report, “ASTM Research Program on Electric Arc Test Method Development to Evaluate Protective Clothing Fabric; ASTM F18.65.01 Testing Group Report on Arc Testing Analysis of the F1959 Standard Test Method—Phase I.”

6.1.5.2 The thermocouple wire is installed in the calorimeter as shown in Fig. 5.

(1) The thermocouple wire shall be bonded to the copper disk either mechanically or by using high melting point (HMP) solder.

6.1.5.3 A mechanical bond shall be produced by mechanically deforming the copper disk material (utilizing a copper filling slug as shown in Fig. 5) around the thermocouple bead.

6.1.5.4 A solder bond shall be produced by using a suitable HMP solder with a melting temperature of  $>280^{\circ}\text{C}$ .

NOTE 9—HMP solders consisting of 5 % Sb-95 % Pb ( $\sim 307^{\circ}\text{C}$  melting point) and 5 % Sb-93.5 % Pb-1.5 % Ag ( $\sim 300^{\circ}\text{C}$  melting point) have been found to be suitable. The  $280^{\circ}\text{C}$  temperature minimum identified above corresponds to the point where melting of the solder bond would be experienced with an  $\sim 17$  second exposure of an  $84\text{ kW/m}^2$  heat flux to a prepared copper calorimeter with a surface area of  $12.57\text{ cm}^2$  and a mass of 18.0 grams. A careful soldering technique is required to avoid “cold” solder joints (where the solder has not formed a suitable bond of the thermocouple to the copper disk).

6.1.6 *Data Acquisition/Analysis System*—A data acquisition/analysis system is required that is capable of recording the calorimeter temperature response, calculating the resulting thermal energy, and determining the test endpoint by comparing the time-dependent thermal energy transfer reading to the empirical performance curve.

6.1.6.1 The data acquisition component must have a minimum sampling rate of four samples per second for temperatures to  $250^{\circ}\text{C}$  with a minimum resolution of  $0.1^{\circ}\text{C}$  and an accuracy of  $\pm 0.75^{\circ}\text{C}$ . It must be capable of making cold junction corrections and converting the millivolt thermocouple signals to temperature.<sup>6</sup>

6.1.7 *Solvents*, alcohol or petroleum solvent for cleaning the copper slug calorimeter.

6.1.8 *Paint*, flat-black, spray type with an absorptivity value of  $>0.90$ .

## 7. Hazards

7.1 This test method uses a high radiant energy source to test materials. The apparatus shall be adequately shielded to minimize any radiant exposure to personnel. Avoid viewing the lamps when energized.

7.2 Perform the test in a hood to carry away combustion products, smoke, and fumes. Shield the apparatus or turn off the hood while running the test; turn the hood on to clear the fumes. Maintain an adequate separation between the radiant heat source and combustible materials.

7.3 The specimen holder and sensor assembly become heated during prolonged testing—use protective gloves when handling these hot objects.

7.4 Observe the appropriate precautions when a specimen ignites or releases combustible gases. Use only the appropriate fire suppression materials for electrical systems if it becomes necessary to extinguish a fire at the unit.

7.5 Refer to manufacturer's Material Safety Data Sheets (MSDS) for information on handling, use, storage, and disposal of chemicals used in this test method.

## 8. Sampling and Specimen Preparation

8.1 *Laboratory Sample*—Select a minimum of a  $1.0\text{ m}^2$  sample size from the material to be tested. Individual test specimens will be produced from this sample.

8.2 *Laundering of Laboratory Sample* :

8.2.1 For specimens submitted without explicit test laundering specifications, launder the laboratory sample for one wash and dry cycle prior to conditioning. Use laundry conditions of AATCC Test Method 135, (1, V, A, i).

8.2.1.1 Stitching the edges of the laboratory sample is allowed to minimize unraveling of the sample material.

8.2.1.2 Restoring test specimens to a flat condition by pressing is allowed.

8.2.1.3 If an alternative laundry procedure is employed, report the procedure used.

8.2.2 For those materials that require cleaning other than laundering, follow the manufacturer's recommended practice using one cleaning cycle followed by drying and note the procedure used in the test report.

8.2.3 Samples submitted with instructions to not launder shall be tested as received.

8.2.4 Record the procedure used in the test report for materials that are submitted with explicit laundering instructions. For samples submitted with instructions not to launder, record in the test report that the samples were tested as received.

8.3 *Test Specimens*—Cut eight (8) test specimens in a diagonal sampling pattern across the prepared laboratory sample. A minimum dimension of 250 mm [10 in.] long and 100 mm [4 in.] wide is required for proper fit of the test specimens in the holder identified in 6.1.2.

8.3.1 If the laboratory sample edges have been stitched to reduce unraveling (see 8.2.1.1), test specimens are cut so they do not incorporate the stitching material.

<sup>6</sup> See NIST Monograph 175 or MNL12 Manual on the Use of Thermocouples in Temperature Measurement.