



Designation: C1168 – 08

Standard Practice for Preparation and Dissolution of Plutonium Materials for Analysis¹

This standard is issued under the fixed designation C1168; the number immediately following the designation indicates the year of original adoption or, in the case of revision, the year of last revision. A number in parentheses indicates the year of last reapproval. A superscript epsilon (ϵ) indicates an editorial change since the last revision or reapproval.

1. Scope

1.1 This practice is a compilation of dissolution techniques for plutonium materials that are applicable to the test methods used for characterizing these materials. Dissolution treatments for the major plutonium materials assayed for plutonium or analyzed for other components are listed. Aliquants of the dissolved samples are dispensed on a weight basis when one of the analyses must be highly reliable, such as plutonium assay; otherwise they are dispensed on a volume basis.

1.2 The treatments, in order of presentation, are as follows:

Procedure Title	Section
Dissolution of Plutonium Metal with Hydrochloric Acid	9.1
Dissolution of Plutonium Metal with Sulfuric Acid	9.2
Dissolution of Plutonium Oxide and Uranium-Plutonium Mixed Oxide by the Sealed-Reflux Technique	9.3
Dissolution of Plutonium Oxide and Uranium-Plutonium Mixed Oxides by Sodium Bisulfate Fusion	9.4
Dissolution of Uranium-Plutonium Mixed Oxides and Low-Fired Plutonium Oxide in Beakers	9.5

1.3 The values stated in SI units are to be regarded as standard.

1.4 *This standard does not purport to address all of the safety concerns, if any, associated with its use. It is the responsibility of the user of this standard to establish appropriate safety and health practices and determine the applicability of regulatory limitations prior to use.*

2. Referenced Documents

2.1 *ASTM Standards:*²

[C757 Specification for Nuclear-Grade Plutonium Dioxide Powder, Sinterable](#)

[C833 Specification for Sintered \(Uranium-Plutonium\) Dioxide Pellets](#)

[C859 Terminology Relating to Nuclear Materials](#)

¹ This practice is under the jurisdiction of ASTM Committee C26 on Nuclear Fuel Cycle and is the direct responsibility of Subcommittee C26.05 on Methods of Test.

Current edition approved Jan. 1, 2008. Published February 2008. Originally approved in 1990. Last previous edition approved in 2001 as C1168 – 01. DOI: 10.1520/C1168-08.

² For referenced ASTM standards, visit the ASTM website, www.astm.org, or contact ASTM Customer Service at service@astm.org. For *Annual Book of ASTM Standards* volume information, refer to the standard's Document Summary page on the ASTM website.

[C1008 Specification for Sintered \(Uranium-Plutonium\) Dioxide Pellets—Fast Reactor Fuel](#) (Withdrawn 2014)³

3. Terminology

3.1 *Definitions*—For definitions of terms used in this standard, refer to [C859](#).

4. Summary of Dissolution Methods

4.1 Most plutonium-containing samples are dissolved with various mineral acids and, except for plutonium metal, with applied heat. Dissolution-resistant materials are dissolved in heated and sealed containers in which pressurization provides a higher temperature than is attained at ambient pressure.

4.2 Another dissolution technique is fusion of refractory plutonium oxide with sodium bisulfate flux.

4.3 The dissolved materials are quantitatively transferred to a tared polyethylene dispensing bottle for subsequent deliveries of weight aliquants for high-precision analysis methods, such as assays, or to a volumetric flask for deliveries of volume aliquants for less precise analysis methods, such as impurity analyses. Acids, usually 1 M, are used as rinses to effect quantitative transfers and as diluents in the polyethylene dispensing bottles and volumetric flasks. The use of water for these purposes can, in some cases, result in hydrolysis of plutonium to produce polymers that, although soluble, are nonreactive in separation treatments or in plutonium assay methods that have no pretreatments, such as fuming with acid.

4.4 Plutonium metal is dissolved with hydrochloric acid or with sulfuric acid.

4.5 Plutonium oxide, calcined at about 1000°C or lower, is dissolved with a mixture of hydrochloric, nitric, and hydrofluoric acids using the sealed-reflux techniques **(1)**.⁴ More refractory plutonium oxide is dissolved with a fusion using sodium bisulfate flux **(2)**. Low-fired (<650°C) plutonium oxide can also be dissolved in a mixture of nitric and hydrofluoric acids in beakers. Plutonium oxide fired at temperatures above 650°C

³ The last approved version of this historical standard is referenced on www.astm.org.

⁴ The boldface numbers in parentheses refer to a list of references at the end of this practice.

may also be dissolved in beakers using a mixture of nitric and hydrofluoric acids when complete dissolution can be demonstrated.

4.6 Uranium-plutonium mixed oxide is dissolved in either of three ways: sodium bisulfate fusion, a heated mixture of nitric and hydrofluoric acids in a beaker, or a mixture of hydrochloric, nitric, and hydrofluoric acids by the sealed-reflux technique.

4.7 Combinations of these dissolution techniques described in 4.4 to 4.6 are sometimes used on difficult-to-dissolve samples.

4.8 Quantitative transfers of samples and subsequent solution are required. Whenever a loss is incurred or even suspected, the sample is rejected. Solutions of dissolved samples are inspected for undissolved particles; if particles are present, further treatment is necessary to attain complete solubility. When analyzing the dissolved sample for trace impurities, caution should be exercised so the dissolution process does not cause the impurity to be lost or does not significantly increase the level of impurity being determined.

5. Significance and Use

5.1 The materials covered are plutonium metal, plutonium oxide, and uranium-plutonium mixed oxide, including those that must meet ASTM product specifications.

5.2 Plutonium and uranium mixtures are used as nuclear reactor fuels. For use as a nuclear reactor fuel, the material must meet certain criteria for combined uranium and plutonium content, effective fissile content, and impurity content as described in Specifications C757, C833, and C1008. The material is assayed for plutonium and uranium to determine if the content is correct as specified by the purchaser.

5.3 The materials not covered are unique plutonium materials, including alloys, compounds, and scrap materials. The user must determine the applicability of this practice to these other materials. In general, these unique plutonium materials are dissolved with various acid mixtures or by fusion with various fluxes. Many plutonium salts are soluble in hydrochloric acid.

6. Apparatus

6.1 *Balances*, for weighing samples and solutions. A balance with a sensitivity of 0.1 mg is necessary; however, a balance with 0.01 mg sensitivity is more desirable. A calibrated balance must be used.

6.2 *Beakers, Test Tubes, and Erlenmeyer Flasks*—Generally, borosilicate glass is recommended; however, the analyst should be sure that safety and sample contamination from the container are considered when choosing appropriate containers.

6.3 *Furnace*, with controller for timed operation. The furnace must be capable of maintaining an even temperature of $\pm 10^\circ\text{C}$ up to 700°C .

6.4 *Heating Equipment*—Hot plates and infrared lamps are used.

6.5 *Inert Atmosphere Glove-Box System*—capability of maintaining less than 10 ppm of H_2O and of O_2 is preferred.

6.6 *Sealed-Reflux Dissolution Apparatus*—The example apparatus is shown in Fig. 1 and Fig. 2 and is further described in Ref (1).

6.6.1 *Stopper*—A stopper which will not react with the dissolution matrix must be used. A solid stopper inserted in a hollow, polyethylene stopper liner has been found to be satisfactory. Certain fluorinated elastomers, designated as FKMs, have also found to be satisfactory.

7. Reagents

NOTE 1—Use distilled or demineralized water for all reagents.

7.1 *Hydrochloric Acid, concentrated* (sp gr 1.18), 12 M.

7.2 *Hydrochloric Acid, 6 M*—Add 500 mL of 12 M HCl to <500 mL of water and dilute to 1 L with water.

7.3 *Hydrochloric Acid, 1 M*—Add 83 mL of 12 M HCl to <900 mL of water and dilute to 1 L with water.

7.4 *Hydrofluoric Acid, concentrated* (sp gr 1.17), 28 M.

7.5 *Hydrofluoric Acid, 1.3 M*—Transfer 4.8 mL of 28 M HF, using a plastic pipet, to a 100-mL plastic graduated cylinder containing <90 mL of water and dilute to 100 mL with water. Transfer to a plastic bottle for storage.

7.6 *Hydrofluoric Acid-Nitric Acid Mixture, 0.05 M HF-16 M HNO₃*—Add 1.8 mL 28 M HF, using a plastic pipet, to 1 L of 16 M HNO₃.

7.7 *Nitric Acid, concentrated* (sp gr 1.42), 16 M.

7.8 *Nitric Acid, 1 M*—Add 62 mL of 16 M HNO₃ to <900 mL of water and dilute to 1 L with water.

7.9 *Sodium Bisulfate, Anhydrous, Fused, NaHSO₄*—Grind the sodium bisulfate to a fine powder just before use, if necessary.

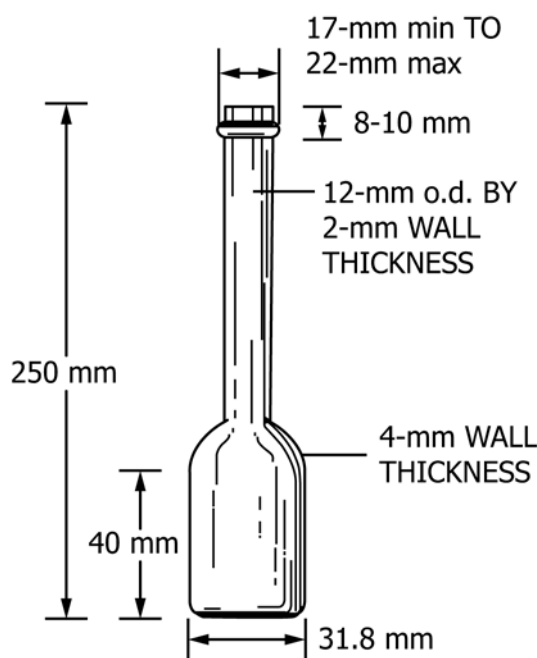

FIG. 1 Sealed-Reflux Dissolution Tube