

---

**Vročje brizganje - Merjenje električne prevodnosti vroče brizganih neželeznih prevlek z metodo vrtničnih tokov**

Thermal spraying - Measurement of the electrical conductivity of thermal sprayed non-iron metal coatings by means of eddy current method

Thermisches Spritzen - Messung der elektrischen Leitfähigkeit thermisch gespritzter Nichteisenmetall-Schichten mittels Wirbelstromverfahren

Projection thermique - Mesurage de la conductivité électrique des revêtements métalliques non ferreux obtenus par projection thermique, à l'aide de la méthode par courants de Foucault

<https://standards.iteh.ai/catalog/standards/sist/cc688d8a-2432-469a-a702-4acb9f4754de/sist-en-16813-2017>

**Ta slovenski standard je istoveten z: EN 16813:2016**

---

**ICS:**

17.220.99	Drugi standardi v zvezi z elektriko in magnetizmom	Other standards related to electricity and magnetism
25.220.20	Površinska obdelava	Surface treatment

**SIST EN 16813:2017**

**en,fr,de**

**iTeh STANDARD PREVIEW**  
**(standards.iteh.ai)**

SIST EN 16813:2017

<https://standards.iteh.ai/catalog/standards/sist/cc688d8a-2432-469a-a702-4acb9f4754de/sist-en-16813-2017>

EUROPEAN STANDARD

EN 16813

NORME EUROPÉENNE

EUROPÄISCHE NORM

November 2016

ICS 25.220.20

English Version

## Thermal spraying - Measurement of the electrical conductivity of thermal sprayed non-iron metal coatings by means of eddy current method

Projection thermique - Mesurage de la conductivité électrique des revêtements métalliques non ferreux obtenus par projection thermique, à l'aide de la méthode par courants de Foucault

Thermisches Spritzen - Messung der elektrischen Leitfähigkeit thermisch gespritzter Nichteisenmetallschichten mittels Wirbelstromverfahren

This European Standard was approved by CEN on 24 September 2016.

CEN members are bound to comply with the CEN/CENELEC Internal Regulations which stipulate the conditions for giving this European Standard the status of a national standard without any alteration. Up-to-date lists and bibliographical references concerning such national standards may be obtained on application to the CEN-CENELEC Management Centre or to any CEN member.

This European Standard exists in three official versions (English, French, German). A version in any other language made by translation under the responsibility of a CEN member into its own language and notified to the CEN-CENELEC Management Centre has the same status as the official versions.

CEN members are the national standards bodies of Austria, Belgium, Bulgaria, Croatia, Cyprus, Czech Republic, Denmark, Estonia, Finland, Former Yugoslav Republic of Macedonia, France, Germany, Greece, Hungary, Iceland, Ireland, Italy, Latvia, Lithuania, Luxembourg, Malta, Netherlands, Norway, Poland, Portugal, Romania, Slovakia, Slovenia, Spain, Sweden, Switzerland, Turkey and United Kingdom.



EUROPEAN COMMITTEE FOR STANDARDIZATION  
COMITÉ EUROPÉEN DE NORMALISATION  
EUROPÄISCHES KOMITEE FÜR NORMUNG

**CEN-CENELEC Management Centre: Avenue Marnix 17, B-1000 Brussels**

<b>Contents</b>	<b>Page</b>
European foreword.....	3
Introduction .....	4
1 Scope.....	5
2 Normative references.....	5
3 Terms and definitions .....	5
4 Measuring process.....	6
4.1 Measuring method.....	6
4.2 Calibration standard.....	7
4.3 Measuring frequency and penetration depth.....	8
4.4 Measuring instruments.....	8
4.5 Factors, which have effects on the uncertainty of the measurement.....	9
4.6 Limit of application .....	9
5 Procedure of the measurement.....	10
5.1 Calibration of the measuring instruments.....	10
5.2 Measurement.....	10
6 Measuring results and their assessment.....	10
7 Test report and documentation.....	11
Annex A (informative) Record for the applied Electrical Conductivity Measurement .....	12
A.1 General.....	12
A.2 Component/part.....	12
A.3 Surface preparation for spraying.....	12
A.4 Spraying procedure for component/part.....	12
A.5 Preparation of measurement .....	13
A.6 Measuring instrument.....	13
A.7 Result of the measured electrical conductivity.....	13
Bibliography.....	14

ITeH STANDARD PREVIEW  
(standards.iteh.ai)

<https://standards.iteh.ai/catalog/standards/sist/cc688d8a-2432-469a-a702-4acb914754dc/sist-en-16813-2017>

## European foreword

This document (EN 16813:2016) has been prepared by Technical Committee CEN/TC 240 “Thermal spraying and thermally sprayed coatings”, the secretariat of which is held by DIN.

This European Standard shall be given the status of a national standard, either by publication of an identical text or by endorsement, at the latest by May 2017, and conflicting national standards shall be withdrawn at the latest by May 2017.

Attention is drawn to the possibility that some of the elements of this document may be the subject of patent rights. CEN shall not be held responsible for identifying any or all such patent rights.

According to the CEN-CENELEC Internal Regulations, the national standards organisations of the following countries are bound to implement this European Standard: Austria, Belgium, Bulgaria, Croatia, Cyprus, Czech Republic, Denmark, Estonia, Finland, Former Yugoslav Republic of Macedonia, France, Germany, Greece, Hungary, Iceland, Ireland, Italy, Latvia, Lithuania, Luxembourg, Malta, Netherlands, Norway, Poland, Portugal, Romania, Slovakia, Slovenia, Spain, Sweden, Switzerland, Turkey and the United Kingdom.

## iTeh STANDARD PREVIEW (standards.iteh.ai)

[SIST EN 16813:2017](https://standards.iteh.ai/catalog/standards/sist/cc688d8a-2432-469a-a702-4acb9f4754de/sist-en-16813-2017)

<https://standards.iteh.ai/catalog/standards/sist/cc688d8a-2432-469a-a702-4acb9f4754de/sist-en-16813-2017>

**EN 16813:2016 (E)****Introduction**

In many applications, the electrical conductivity is a relevant technical parameter. For testing of imperfections in components or technological material properties the eddy current method can be very well applied. It can be detected or determined, for example:

- defects in welds;
- imperfections or change in the structure of a component, for example, due to aging processes in structures made out of aluminium;
- change in structure caused by temperature effects;
- thickness;
- physical material properties such as the electrical conductivity.

Due to an interaction between high frequency magnetic fields, emitted from a measuring probe, and the eddy currents induced in the object to be measured the electrical conductivity can be determined, e.g. according to ASTM E 1004 or can be used for fast and contact less measurements of a coating thickness according to EN ISO 21968.

Due to the manufacturing process thermal sprayed coatings contain a layer orientated structure. Dependent on the material used, it can also contain oxides and/or inclusions as well as porosity created due to splat boundary effects during spraying.

Besides the structure with its grain boundaries, dislocations, internal stresses and impurities, e.g. oxide skins, the specific gravity of a material plays an important role for the level of the electrical conductivity. In order to produce the highest possible level of electrical conductivity in the coating, the influencing factors for the thermal spraying process should be minimized.

## 1 Scope

This European standard specifies the procedure of the measurement of the electrical conductivity of non-Ferro-magnetic thermal sprayed coatings. By this measurement the absolute value of the electrical conductivity in the coating sprayed on component can be determined as well as also deviations from the agreed rated value can be used to control a running production. With that, a remarkable contribution can be applied to process and quality assurance measures of a manufacture process.

## 2 Normative references

The following documents, in whole or in part, are normatively referenced in this document and are indispensable for its application. For dated references, only the edition cited applies. For undated references, the latest edition of the referenced document (including any amendments) applies.

EN ISO 21968, *Non-magnetic metallic coatings on metallic and non-metallic basis materials - Measurement of coating thickness - Phase-sensitive eddy-current method (ISO 21968)*

## 3 Terms and definitions

For the purposes of this document, the following terms and definitions apply.

### 3.1

#### electrical conductivity

$\sigma$

physical value, which shows the ability of a material – in this case of a thermal sprayed coating – to conduct the current

Note 1 to entry: It is defined to be the constant of proportionality between the current density and the electrical field intensity within the general Formula (1) of the ohmic law.  $\sigma$  is measured in S/m.

$$J = \sigma \times E \quad (1)$$

where

$J$  is the current density;

$\sigma$  is the electrical conductivity;

$E$  is the field intensity.

### 3.2

#### electrical resistance

$R$

value, which defines the electrical voltage, which is needed that a certain current can flow through an electrical conductor

Note 1 to entry: The unit is ohm ( $\Omega$ ).

**EN 16813:2016 (E)****3.3****specific electrical resistivity**

property of material, which is the result of the electrical resistance in a homogenous part with a constant current intensity distribution across the constant cross-section and length of the conductor and an ohmic resistance

Note 1 to entry: The specific electrical resistance, see Formula (2), depends on the temperature of material and is the reciprocal value of the electrical conductivity ( $\rho = 1/\sigma$ ). The unit is ohm metre ( $\Omega \times \text{m}$ ).

$$\rho = R \times \frac{A}{L} \quad (2)$$

where

- $\rho$  is the specific electrical resistivity in  $\Omega \times \text{m}$ ;
- $R$  is the ohmic resistance;
- $A$  is the constant cross-section of the conductor;
- $L$  is the length of the conductor.

**4 Measuring process****4.1 Measuring method**

**iTeh STANDARD PREVIEW**  
(standards.iteh.ai)

Measuring of the absolute value of the electrical conductivity takes place usually by a current voltage measurement. However, this method is usually applied in laboratories only.

If the electrical conductivity shall be determined in a component on site, primarily eddy current processes are applied. To measure the electrical conductivity of non-magnetic metals, such as aluminium, copper, brass, titanium, chrome-nickel-steel, etc. Therefore, the phase-sensitive eddy current measurement procedure is very suitable. By that, the measuring probe fed from a generator with alternating current of a certain frequency is to be put to the object to be measured or to be brought into small distance to its surface. This exciter current generates a magnetic field of high frequency, which induces eddy currents in the material to be tested (in this case the coating respectively the base material), their intensity and penetration depth depend on its electrical conductivity. On the other hand the magnetic field induced by eddy currents overlaps the generating field. The generated resulting magnetic field is detected by a measuring coil. By that, the induced voltage is a function of the electrical conductivity of the object to be measured and can be used as a signal for its measuring. See Figure 1.

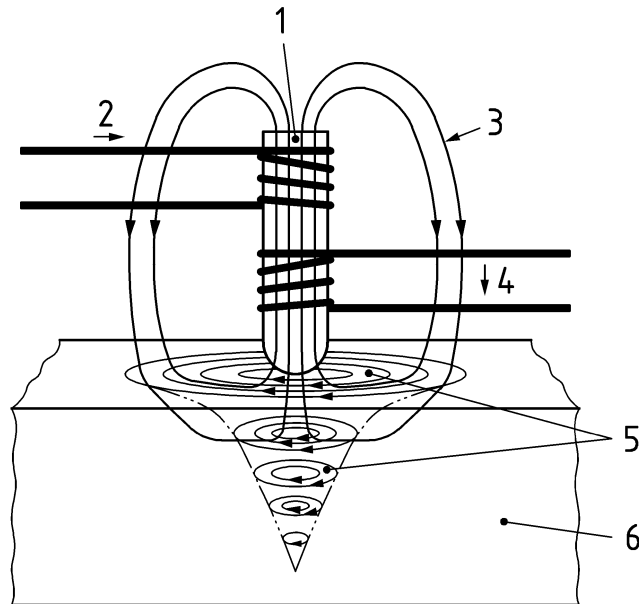

**Key**

- |   |   |
|---|---|
| 1 ferrite core of the probe                 | 4 measuring signal                          |
| 2 exciting current                          | 5 eddy current induced                      |
| 3 high frequency magnetic alternating field | 6 electrically conductive non-ferrous-alloy |

**Figure 1 — Phase-sensitive eddy current measuring method**  
(standards.iteh.ai)

Using the phase-sensitive eddy current measurement procedure the phase changing between exciter current and measuring signal is to be transferred into a conductivity value. This measuring value is independent from the distance between the probe and the coating surface for a certain arrangement, which depends on the type of the probe. By that, a non-contactable determination of the conductivity can be applied also using this method, for example, below a varnish or a synthetic material coat. Using an adequate measuring frequency the influence of the surface roughness remains low.

**4.2 Calibration standard**

Using the phase-sensitive eddy current measurement procedure the measuring value found in the component will be compared to the calibration standard as a reference standard, which conductivity is very well known. Standards for calibration of the measuring instrument are available for the whole conductivity range. Usually, they are also supplied from the measuring instrument producer.

Because the calibration standards are subject to changes in properties due to use they have to be recalibrated at regular time periods or to be replaced.